

SMITHSONIAN INSTITUTION
LIBRARIES
SMITHSONIAN INSTITUTION
LIBRARIES
SMITHSONIAN INSTITUTION
LIBRARIES
SMITHSONIAN INSTITUTION
LIBRARIES

22
57
H.M.

HISTORY OF OLD SHEFFIELD PLATE

BEING AN ACCOUNT OF THE
ORIGIN, GROWTH, AND DECAY OF THE INDUSTRY

AND OF THE
ANTIQUE SILVER

AND
WHITE OR BRITANNIA METAL TRADE

WITH
CHRONOLOGICAL LISTS OF MAKERS' MARKS AND NUMEROUS
ILLUSTRATIONS OF SPECIMENS

BY
FREDERICK BRADBURY
//

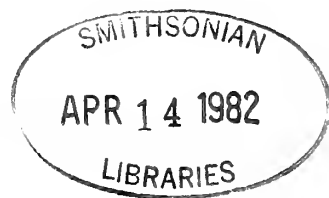

MACMILLAN AND CO., LIMITED
ST. MARTIN'S STREET, LONDON

1912

COPYRIGHT

PAWSON AND BRAILSFORD, PRINTERS,
SHEFFIELD.

TO
THE MASTER, WARDENS, SEARCHERS, ASSISTANTS
AND MY FELLOW FREEMEN
OF THE
WORSHIPFUL COMPANY OF CUTLERS
IN HALLAMSHIRE.

THIS HISTORY OF AN INDUSTRY INVENTED AND PERFECTED BY MEMBERS
OF OUR ANCIENT CORPORATION IS RESPECTFULLY DEDICATED BY

THE AUTHOR.

PREFACE

THE object of this work is to extend a knowledge of the now highly valued specimens of Old Sheffield plated wares; to trace the origin of the processes by which they were made, to give some particulars of the manufacturers and their factories, the localities, the workmen and the methods employed; with other details that may be of interest both to collectors and to those who deal in the products of an old-time industry that has to-day fallen almost entirely into disuse. It is inaccurate to say that the manufacture of articles from silver plated on copper by the process of fusion, with silver edges, silver shields and thin silver mounts, is a lost art. A large number of the dies from which they were formerly made remain in existence in Sheffield, while the mills still roll out the sheets of fused silver and copper as of yore. Workmen there are, too, who can undertake the difficult processes of soldering on silver mounts, rubbing in silver shields, and applying delicate silver edges. But the industry in its old form seems doomed never to be resuscitated commercially; we live in an age when people who purchase plated wares enquire for them in their cheaper forms. The manufacturers and retailers combine to satisfy the public to the full in this respect. The idea is creeping in that modern plated goods are only required to last for a few short years—until such time as the owners shall either tire of their styles or the articles be no longer of use.

In writing on the subject of Old Sheffield Plate it has been found essential to include a few particulars concerning the manufacture of close plated articles, silver cutlery, silver and Britannia metal. The origin of the method of soldering layers of fine silver on to baser metals—which came eventually to be described as “close plating”—is so old as to be lost in the regions of obscurity.

Out of the cutlery trade grew the manufacture of silver and plated goods. Afterwards a demand sprang up for a cheaper material than Sheffield plate, and one more serviceable than pewter. Then was evolved “Britannia metal.” In Sheffield the principal makers in the old days, as at the present time, made cutlery, and both silver and plated articles; whilst latterly the making of Britannia metal goods was not altogether to be despised where a firm had premises large enough to warrant the introduction of further manufacturing enterprise.

In dealing with the foregoing subjects, the main object in view has been to represent, as correctly as possible, the process of manufacture by illustration, with reproductions of specimens, names of makers and marks found on both Old Sheffield and close plated articles. The lists of names of Sheffield manufacturers who registered a plater's mark at the Sheffield Assay Office embrace practically the whole of the contemporary silversmiths. Consequently it has been considered necessary to present as far as possible an accurately arranged chronological representation of the makers' punches as well as the actual date letters, shapes and styles of crowns, and lions found on the antique silver.

It is hoped that these matters are now set forth on clearly defined lines so as to give every possible assistance to collectors desirous of investigating the origin of their specimens.

The Author's task has been greatly facilitated by the publication of the official registers of all the silver and plate marks entered on the books of the Sheffield Assay Office, to whose guardians he has pleasure in acknowledging his indebtedness.

Even life-long inhabitants of Sheffield find the greatest difficulty in unearthing trustworthy information as to the conditions under which the industry was founded and developed, but diligent search among the dusty archives of his own and other firms has enabled the Author to rescue many forgotten facts throwing new light on these conditions. At the same time he has endeavoured, with what success the reader must judge, to give human interest to the narrative by the inclusion of all that is known as to the personality and character of the worthies to whom Sheffield Plate owes its origin and its excellence.

The quantity of Old Sheffield Plate to be found to-day in this country made abroad, or found abroad but made in England, has necessitated the writing of a separate article on this subject. It is hoped that the marks reproduced and the particulars given in Part VII. of this work will tend to elucidate a matter that has for a considerable time past greatly puzzled collectors.

The author trusts that the remarks under the heading "Where Old Sheffield Plate is known to have been made" will also help definitely to settle the much vexed question as to the locality in which the manufacture of articles from fused plate was formerly carried on.

It is greatly to be hoped that some day a chronicler will appear, sufficiently interested to extend research to the whole question of marks on antique cutlery made in Sheffield, not only silver and plated, but also steel. On this matter very interesting particulars, extending far beyond the few details given in this book, have yet to be compiled.

On the subject of Britannia metal—an industry that has held its own now for the past 140 years—apart from the few lines herein recorded, nothing, as far as the author is aware, has yet been published.

I have most gratefully to thank Mr. Robert Eadon Leader, B.A., who is himself a descendant of one of the earliest and most accomplished of the silversmiths and platers associated with our city and who has inherited the enthusiasm for the town of his birth, its trades, its personalities and the early history on which all true natives of Sheffield pride themselves so much, for the very valuable assistance he has given with the historical parts of the book. Mr. Leader's collaboration has been of peculiar value on account of his familiarity with our earliest records, topographical and personal, and because he has devoted himself to preserving, ere too late, details relating to our ancestors, their trades, customs, manners and interests, with much else which, in the changes due to the rapid development of the city, the introduction of improved methods of manufacture and the colossal growth of the huge steel factories, might soon have been lost beyond recall.

To Mr. M. S. D. Westropp, of Dublin, Mr. Clement H. Casley, of Ipswich, Mr. Arthur Westwood, of Harborne, Birmingham, and Mr. B. B. Harrison, of Sevenoaks, I have to tender my sincere thanks for the untiring assistance they have rendered in the recording of and searching for particulars concerning unusual specimens and other matters of interest; to Mr. W. P. Belk, of Sheffield, for many suggestions of arrangement which have proved of inestimable service; and to Mr. G. R. Travis, of Sheffield, for assistance in connection with the subject of Old Sheffield Plate in France. From Mr. H. Pawson, of Sheffield, I have had most able assistance in

the unearthing of local data and interesting material. Much help has been given me by Mr. A. Nicholson, of the Sheffield Assay Office. His grandfather has been aptly described, by one who can just remember him, as the last of the Old Sheffield Plate gentlemen manufacturers. The memoirs he left behind, kindly placed at my disposal, have been of the greatest assistance.

I am also under obligation to my brothers and Miss Bradbury, to the staff of T. Bradbury & Sons, particularly Mr. G. H. Cottam, for assembling the specimens of dies, tools, etc., illustrated; to Mr. G. Kinman for guidance in technical matters; to Mr. H. Hunt for collecting information from old ledgers and manuscripts and assistance given in recording marks; to Mr. T. Bradley and Mr. S. W. Turner.

To both Major Carrington, of Bideford, and the late Mr. Wm. A. Carrington, of Bakewell, for assistance in pedigree research; to the late Mr. W. A. Ellis and Mr. P. M. Ellis, of Birmingham, in connection with the practical part of plating by fusion; also to Mr. Walter Willson, of Richmond, Mr. J. H. Ellett Lake, of Exeter, and Mr. F. Lyne, of Bristol, whose careful records of the marks on the various pieces passing through their hands have been of great value to me and who have also sent me unusual specimens for inspection; to Mr. J. B. Mitchell-Withers, of Sheffield, for supplying information concerning his ancestor, Mr. T. Boulsover; also to Mr. W. Sissons for valuable assistance in the compilation of records concerning the early history of his firm and other matters in connection with the subject of Old Sheffield Plate, I owe grateful acknowledgments.

For assistance in collaboration and loans of wares for illustration I am indebted to the Countess Sackville, the Earl Fitzwilliam, Sir T. Freake, Bart., Mr. Samuel Roberts, M.P., Col. H. C. Surtees, Mr. J. G. Nairne, of the Bank of England; Mr. Walter Prideaux, of the Goldsmiths' Hall; the late Rev. J. Matthews, of Broxbourne; and the Rev. F. L. Shaw, Vicar of Eyam; the Guardians of the Assay Office, the Corporation of Cutlers, Mr. L. T. O'Shea, of the University; Mr. A. C. C. Jahn, of the School of Art; Mr. Bernard Watson, M.A., the Assay Master; Mr. J. C. Bennett, of the Sheffield Smelting Co.; Col. Hughes, C.B., C.M.G., Mr. D. Vickers, J.P., Mr. Arnold T. Watson, Mr. James Dixon, J.P., Mr. Lennox Dixon, Mr. T. Bowker, Mr. A. L. Billot, Mr. T. R. Ellin, Mr. R. T. Wilson, Mr. W. Thorpe Haddock, Mr. A. J. Hobson, J.P., and Miss Hobson, Mr. B. Hoole, Mr. Herbert Hutton, Mr. Sidney Nowill, Mr. A. C. Ridge, Mr. Leslie Roberts, Mr. John Rodgers, Mr. H. B. Sandford, Mr. T. A. Scott, Mr. Henry Steel, Mr. W. O. Stratford, Mr. W. Walker, Mr. Cecil Wilson, all of Sheffield; Mr. W. L. Spiers, of Sir John Soane's Museum; Mr. L. Crichton, Dr. W. Jobson Horne, Mr. George Lambert, Mr. A. M. Parsons, Mr. W. H. Rickatson, Mr. Frank C. Wheeler, Mr. G. N. Withers, Mr. Waldeck, all of London; Mr. Hiatt Baker, Almondsbury, Gloucester; Mr. H. Hamilton, Belfast; Dr. J. Torrey, Junr., Blundellsands; Mr. Joseph Spiridion, Cardiff; Mr. S. Barnett, Chester; Mr. H. S. Benzie, Cowes; the Art and Industrial Division of the Irish National Museum, Mr. J. J. Buckley and Mr. L. A. West, Dublin; Mr. Hamilton Blake and Mr. E. J. Inches, Edinburgh; the late Bailie Sorley, Glasgow; Mr. Francis Mallett, Bath; Mr. G. H. Clapham, Manchester; Mr. F. A. Hawley, Hampstead; Mr. J. and Mr. H. Barraclough, Leeds; Mr. J. W. Usher, of Lincoln; Mr. Alfred Bethell, Newton Kyme, Tadcaster; Mr. J. Taylor, Northfield, Birmingham; Mr. Alfred T. Johnstone, Rednal, and Mr. A. F. de Navarro, Broadway, Worcestershire; Mr. W. T. Freemantle, Barbot Hall, Rotherham; Mr. J. Tearoe, J.P., Sanderstead; Mr. E. Plimmer, Shrewsbury; Dr. A. M. Roberts, Southport; Mr. C. A. Head, Hartburn Hall, near Stockton-on-Tees; Mr. Norman Haggie, Sunderland; Dr. George Porter, Surbiton; Mr. H. S. Hare, Taunton; Mr. F. Ross,

Winchester; Mr. W. T. Sears, Normanhurst, Northampton; Mr. Ernest Hill, Woking; Mr. Percy W. L. Adams, Wolstanton, Staffs.; Mr. W. J. Fieldhouse, Wooten Wawen, and Mr. T. P. Barker, Four Oaks, Warwickshire; Mr. W. Base, Birmingham; Herr Felix Alfermann, Berlin; Mons. Henri Bouilhet, Mons. Pinton, and Mons. Christofle, Paris; Mr. Holbrook, New York.

Amongst members of the trade, my thanks for specimens kindly lent are due to Birch & Gaydon, Chapple & Mantell, Dobson & Son, Elkington & Co., Heming & Co., Holmes & Maplesden, Spink & Son Ltd., M. & S. Lyon, Mappin & Webb, F. B. Thomas & Co., Vander & Hedges, and Lambert, all of London; W. Dickinson and E. J. Vokes, Bath; S. D. Neill, Belfast; D. & M. Davis and I. S. Greenberg, Birmingham; J. H. George, J. H. Mogg and F. S. Smith, Bristol; T. Worthington, Burton-on-Trent; H. Winston, Cardiff; A. Jack & Co., Martin & Co., and A. Paget, Cheltenham; Butt & Co. Ltd., and Lowe & Sons, Chester; H. C. Galton, Christchurch; H. E. Norris, Cirencester; E. Johnson, J. E. Ledbetter, L. Wine and B. Wine, Dublin; Wilson & Sharp, Edinburgh; Bruford & Son, and J. E. Lake & Son, Exeter; R. & W. Sorley, Glasgow; C. Basker & Son, Grantham; Oswin & Co., Hereford; B. Mallinson & Son, Huddersfield; Green & Hatfield, Ipswich; S. Leighton, Lancaster; Curtis & Horspool, and William Withers, Leicester; E. E. Dunthorne, Robert Jones & Sons, and R. H. Reed & Son, Liverpool; L. Hall, Louth; Sidney Blackford, Lynton; E. T. Biggs, Maidenhead; M. Beaver, D. F. Davis, and John Hall & Co., Manchester; H. T. Simmonds, Monmouth; Ford & Son, Newark; C. Ince, Newport; Robinson & Co., Northampton; George Wood, Nottingham; F. Cambray, Oxford; E. Emanuel, Portsea; Page, Keen & Page, Plymouth; J. Cockburn and J. H. Jarvis, Richmond; R. Smith & Son, Scarborough; H. E. Warren, Sevenoaks; H. Cooplund, T. Smallwood, and Ford & Son, Sheffield; Cole & Son, Sherborne; Robinson & Co. Ltd., Shrewsbury; M. Emanuel, Southampton; Franklin & Hare, Taunton; J. & C. O'Donoghue, Torquay; Eustance & Co., Warrington; J. Comber, Woking; Kemp & Wilcox, Wolverhampton; Edgar Vincent, Yeovil; Greenwood & Sons, and H. Hardcastle, York.

FREDK. BRADBURY.

SHEFFIELD,
OCTOBER, 1912.

CONTENTS

	PAGE
INTRODUCTION	I—3
PART I.	
THE INVENTION.	
Oldest methods of plating—Process of close plating—Boulsover's discovery of plating by fusion—Description of the process—To what purposes the invention of fused plate was first applied, and how the two Pioneers subsequently followed other industrial undertakings—The new industry and its possibilities—Buttons—Boxes—Buckles	4—23
PART II.	
THE EARLIEST MANUFACTURERS OF SHEFFIELD PLATE.	
Thomas Boulsover—Joseph Hancock—Thomas Law—Henry Tudor—Thomas Leader—Thomas Bradbury—Samuel Roberts—Thomas Nicholson—Matthew Boulton	24—51
PART III.	
HISTORY OF THE TRADE.	
On workmanship and apprentices—Inn proprietors and Old Sheffield Plate—How the demand for Sheffield Plate increased and decreased—How the plate was destroyed ; why the dies were dispersed ; and what became of the Manufacturers and their Factories—The cutting of dies—Early trade prices for tools and materials, from the books of an Old Sheffield Plate manufactory—Descriptions of old furnaces : casting furnace, plating furnace, stripping place—Where the Old Sheffield Plate makers obtained their glass	52—70
PART IV.	
PROCESSES, PRACTICES AND INVENTIONS.	
Application of gold in the making of Old Sheffield Plate—Process of chasing—Plating on both sides of the ingot—Deposits of silver—Invention of plated wire—Introduction of silver edges—Introduction of engraving—Necessity for silver shields for engraving crests, monograms and inscriptions—Method of soldering-in extra strongly plated metal for engraving crests—Invention of applying silver shields by heat—Process of French plating	71—97
PART V.	
SURVIVING METHODS, WITH ILLUSTRATIONS OF WORKSHOPS, TOOLS, AND MATERIALS.	
Use of steel dies : (a) The Stamp Shop ; (b) The fixing of dies—The Draw Bench—The Foot Lathes—The Hand Rolls—Raising—Swaging—Spinning—Pierce working—Soldering and mounting—Flat hammering—Tinning—Burnishing	98—132
PART VI.	
INNOVATIONS THAT REVOLUTIONIZED THE OLD TRADE.	
Last stages of the manufacture of fused plate, and a description by an old workman—Introduction of German silver—Expert opinion on the comparison to be drawn between German silver and copper as a foundation metal—Origin of the process of electro-plating—Introduction of electro-plating—Expert opinion on the future of electro-plate—Method of silver-plating by electro-deposition—Saving of labour consequent on the introduction of electro-plating	133—144

PART VII.

LOCALITY OF MANUFACTURE.

PAGE

Where Old Sheffield Plate is known to have been made—Making of articles from fused plate in Nottingham—Old Sheffield Plate in Ireland—Old Sheffield Plate in Scotland—Old Sheffield Plate in America—Old Sheffield Plate on the Continent ; importation into England, and manufacture abroad—Manufacture of Sheffield Plate in France - - - - - 145—172

PART VIII.

ADVICE TO COLLECTORS—DESIGNERS.

How to judge Old Sheffield Plate—Reproductions or “ fakes ”—How reproductions may be detected—On renovation—Method of dealing in old silver and Old Sheffield Plate—Sale-room values of Old Sheffield Plate—Approximate dates of various articles made in Old Sheffield and electro-plate—Designers and their influence in the designs of Old Sheffield Plate : Paul Lamerie’s designs ; Chippendale’s influence in design : The “ Adam ” period, and the potters named Adams - 173—195

PART IX.

ON ASCERTAINING DATES OF SPECIMENS.

Extracts from a Directory of the year 1774 of articles that were then made in Sheffield, in silver and Sheffield Plate—Old Sheffield Plate articles as indexed in an old pattern book between the years 1788 and 1815—Illustrations of articles that were made in Sheffield both in silver and Sheffield plate—Illustrations and descriptions of Old Sheffield plated articles, with the approximate dates of their manufacture and names of makers—Reproductions of Illustrations from makers’ catalogues, arranged in chronological order - - - - - 196—424

PART X.

LIST OF MAKERS AND THEIR MARKS.

An explanation of the marks to be found on Old Sheffield Plate, with a few particulars concerning the firms who used them—Workmen’s Marks and Manufacturers’ Numbers—Approximate dates of the manufacturers’ earliest connection with the fused plate industry previous to 1773—Extracts from lists of Manufacturers, from Sketchley’s Sheffield Directory, 1774—Extracts from lists of Manufacturers, from Bailey’s Northern Directory and other sources, 1781—List of Makers and Marks used by manufacturers of fused plated and close plated articles after the passing of the Act of 1784 - - - - - 425—452

PART XI.

OTHER INDUSTRIES CONNECTED WITH OLD SHEFFIELD PLATE.

THE MANUFACTURE OF SILVER.

Old Sheffield and Silver-handled Cutlery—Ivory stained green for knife handles and other purposes—Antique Silver in Sheffield—The Sheffield Assay Office—The Sheffield Assay Office Marks—The Date Letters to be found on silver manufactured in Sheffield, arranged in chronological order—The Sheffield Silversmiths’ Marks—List of Makers of Antique Silver who registered at the Sheffield Assay Office, with marks taken from articles they made - - - - - 453—493

PART XII.

THE BRITANNIA METAL INDUSTRY.

Invention of Britannia Metal—Britannia metal as distinct from Pewter—Origin of Pewter ware - - - - - 494—501
 INDEX - - - - - 503—535
 INDEX TO MARKS - - - - - 536—539

LIST OF ILLUSTRATIONS

- Adams, William, portrait, 193.
 Altar Cruet, 168.
 Apprenticeship deed (1800), 54.
 Arganda lamp, 395.
 Argentine metal, articles made in, 144, 213, 386.
 Argyle gravy holders, 203.
 Bands for engraving, 91.
 Barber's dish, 391.
 Baskets, cake, bread and fruit, 80, 205-12.
 Illustrated designs from catalogue (1770 and 1775), 400, 401.
 Beakers, 351.
 Bell, 389.
 Biggins for coffee, 201, 262.
 Borders of salvers, 76, 77, 83, 126, 316-26.
 Bougie Boxes, 251.
 Boulsover, T., portrait, 24.
 Boulsover's enterprise in Whiteley Wood, Sheffield, relics of, 3.
 Boulton commemorative medal, 48.
 Boulton, M., junr., portrait, 48.
 Boulton's Soho factory, 49.
 Bowl, 351.
 Boxes, snuff and patch boxes, 20, 21.
 Bread tray, 211.
 Breakfast dish, 267, 432.
 Bright cut deep engraving, 86.
 Britannia Metal, antique specimens of, 498-9.
 Buckles, 23.
 Burnishing, 130.
 Burnishing tools, 81, 84, 131.
 Butter boats, *see* sauce or butter boats.
 Butter dishes, 92, 213.
 Buttons, 18.
 Caddy spoons, 72, 336.
 Candelabra, 202, 232-44, 296.
 Silver candelabra purchased as Old Sheffield, 202.
 Telescopic patent candelabra, 238.
 Candlesticks, 33, 180, 190, 191, 199, 220-31.
 Adam Candlestick, 156.
 Britannia metal telescopic candlesticks, 499.
 Chamber candlesticks, 248, 249.
 Combination chamber candlestick and pair of ordinary table candlesticks, 218.
 Illustrated designs from catalogues (about 1775), 402; (1778-88), 405; (1780), 406; (1786), 409; (1788), 410; (1801), 414; (1844), 422.
 Sconces, 236, 390.
 Silver candlesticks.
 London made, 191.
 Sheffield made, 190, 454.
 Slide or telescopic and patent candlesticks, 217.
 Taper candlesticks and winders, 250, 251.
 Card tray, 213.
 Centre pieces, *see* épergnes.
 Chantrey, Sir F., portrait, 193.
 Chasing, 73, 74, 99, 150, 151, 189.
 Cheese toasters, 252.
 Illustrated design from catalogue (about 1822), 418.
 Cigar holder, 375.
 Clock, 167.
 Close plated articles, 8, 144, 244, 246.
 Coach lamp, 394.
 Coasters, 165, 200, 253, 255-7.
 Illustrated designs from catalogue (about 1770-90), 399.
 Coffee biggins and pots, 85, 201, 259-263, 435.
 Biggin in Sheffield-made silver and Sheffield Plate, 201.
 Different classes, 260-3.
 Illustrated design from catalogue (about 1798), 413.
 Coffee services, 357, 358.
 Illustrated designs from catalogues (about 1795), 412; (1850), 424.
 Coins, 395.
 Combined and interchangeable articles.
 Candelabra, 239, 242.
 Candelabra and épergnes, 240, 241, 243.
 Chamber candlestick and table candlesticks, 218.
 Coffee pot stand and lamp and teapot, 259.
 Cruet and pickle frame, 274.
 Cruet or soy frame, 273.
 Egg frames and toast racks, etc., 370-3.
 Inkstand, sand sprinkler and candlestick, 394.
 Pot à sucre avec douze cuilliers autour, 57.
 Communion plate, 168, 275.
 Copper ingot prepared for plating by fusion, 12.
 —After plating, 13.
 "Cramped Seam," 111.
 Cream basin from catalogue (about 1798), 413.
 Cream jugs, 339, 343-4, 498.
 Illustrated design from catalogue (about 1784), 408.
 Crests, monograms, etc., method of engraving before invention of soldering in silver shields, 88.
 Cruet frames and soy frames, 55, 70, 271-4.
 Illustrated designs from catalogue (about 1778), 404.
 Cups, 150, 348-9, 351.
 Custard or junket dish, 92.
 Cutlery, 455, 456, 457.
 Decanter, 253.
 Decanter labels, 303.
 Decanter stands, 165, 200, 253, 255-258.
 Illustrated designs from catalogue (about 1798), 399.
 Dessert stands, *see* épergnes.
 Detachable parts in silver, 462.
 Dies, 100, 102—Stampings from dies, 101, 103.
 Dish and plate covers, 164, 165, 166, 264-8.
 Dish crosses, 62, 267, 283.
 Dish rims, 282-3.
 Dish rings, 278-81.
 Dish wedge, 392.

- Dollars—Silver and forged plated, 395.
 Drafting punch, 103.
 Draw bench (1775), 106.
 Draw-handle, Adam period, 388.
 Drawing wire, 107.
 Ear speculum, series of, 390.
 Ear trumpet, folding pocket, 390.
 Edges, silver—Hard soldered edges, 85, 92.
 Edges (or borders) of salvers, 76, 77, 83, 126.
 Egg boilers, 372, 373.
 Egg frames, 370, 371, 372.
 Engraving, 86, 88, 91.
 Entrée, etc., dishes, 283-9.
 Illustrated design from catalogue (about 1818), 417.
 Epergues, centre-pieces, dessert stands and plateaux, 240, 241, 243, 291-6.
 Illustrated design from catalogue (about 1839), 420.
 Factory, 46, 49.
 "Fakes," 177, 181.
 Fire-gilt articles, 72, 189.
 Fish slices, 121, 163, 392.
 Flask with cover, 388.
 Flat hammering, 127.
 Flaxman, John, portrait, 193.
 Foot lathes, 1775, 108.
 Forks and spoons, 336, 337.
 Fowl dish, 289.
 France, plated ware made in, 163-9.
 French plating, tray repaired by, 97.
 Furnaces, casting and plating, 66.
 German silver, articles made in, 144, 213, 386.
 Gilt articles, 72, 189.
 Goblet, 349.
 Gravy holders, 203.
 Green stained ivory handles to knives, forks, etc., 457.
 Hammering stake, 128.
 Hand rolls, 109.
 Hash dishes, 284, 288, 289.
 Hollow jacketed vessels, 203, 204, 288.
 Honey hive, 389.
 Hot water or shaving pot, 204.
 Inkstands, 297, 298-300.
 Illustrated designs from catalogue (about 1789), 411.
 Invoices, original invoices, 199.
 Irish style, articles chased in, 150, 151, 278.
 Ivory stained green handles to knives, forks, &c., 457.
 Jugs or pitchers, 306-8.
 Cream jugs, 339, 343, 344.
 Milk jug, 344.
 Sheffield plate and silver (1755-60), 32.
 Staffordshire ware, 339-40.
 Kettles on stands with lamps, 169, 301-2.
 Knife, fork and spoon tray, 269.
 Knife, silver handled, 455.
 Knitting sheath or bodkin holder, 393.
 Labels for decanters, 253, 303.
 Designs from catalogue (1770-90), 399.
 Lamps, 391, 394, 395.
 Leg of mutton holder, 392.
 Lemon strainer, 393.
 Liquor frames, 199, 304, 305.
 Loving cups, 150, 348, 349, 351.
 Mace, 388.
 "Faked" piece, 177.
 Marks, lists of.
 Foreign manufacturers of Sheffield Plate, 171-2.
 Sheffield assay office date letters, etc., 467-9.
 Sheffield platers and close platers, 441-52.
 Sheffield silversmiths and cutlers, 455, 458, 459, 472-93.
 Maundrill, 107.
 Meat dishes, 266.
 Mercurial gilt articles, 72, 189.
 Miscellaneous pieces, 387, 388-95.
 Monteith or wine glass cooler, 189, 383.
 Mounts, various forms of, 76, 77, 80, 83, 85, 86, 124, 126, 136, 279.
 Muffineers, 315.
 Mug, 339.
 Mustard pots, 314, 498.
 Illustrated designs from catalogues (about 1789), 411; (1804), 415 (1848), 423.
 Nicholson, Thomas, portrait, 46.
 Nicholson's factory, 46.
 Nutmeg grater, pocket, 390.
 Omelet pan, design from catalogues (about 1848), 423.
 Patch boxes, 21.
 Pepper pots, 315, 498.
 Percolator or strainer, 262, 393.
 Pickslay's show rooms in Sheffield, 195.
 Pie dish, 288.
 Pierce work, 121.
 Punching and piercing machines, 119
 Beds and punches used in machine, 120.
 Saw piercing, 118.
 Pipe lighters, 375.
 Plateaux, 294, 295, 296.
 Plated wire, use of, 80, 86.
 Plates, 165, 268, 270.
 Porringer, 349.
 Portraits.
 Adams, William, 193.
 Boulsover, T., 24.
 Boulton, Matthew, Junr., 48.
 Chantrey, Sir F., 193.
 Flaxman, John, 193.
 Nicholson, Thomas, 46.
 Roberts, Samuel, 39.
 Tudor, Henry, 35.
 Wedgwood, Josiah, 193.
 Pot à sucre avec 12 cuilliers autour, 57.
 Preserve dish, 212.
 Raising by hand, 110, 112.
 Reproductions or "fakes," 177, 181.
 Roberts, Samuel, portrait, 39.
 Russian samovar, 163.
 Salt cellars, 310-3.
 Illustrated designs from catalogues (about 1765-85), 398; (1804), 415; (1848), 423.
 Sheffield-made silver, 200, 280, 466.
 Salvers (or waiters) and trays, 25, 72, 73, 76, 77, 86, 90, 95, 97, 99, 126, 135, 136, 151, 161, 162, 166, 201, 316-26.
 Austria, tray probably made in, 161.
 Borders and mounts, 76, 77, 83.
 Boulsover, salver presented by, to his daughter in 1760, 25.
 French make, 166.
 Russia, tray made in, 162.
 Silver salver, 201.
 Stages of manufacture, 135, 136.
 Samovar, 163.
 Sauce or butter boats and sauce tureens, 85, 329, 332-4.
 Designs from catalogues (about 1777), 403; (about 1835), 419.
 Tureen with hot water jacket, 204.
 Saucepans, 32.
 Design from catalogue (1848), 423.
 Scallop shells, 92, 391.
 Sconces, 236, 390.
 Second course dishes and warmers, 287, 288.
 Shaving lamp, 391.
 Shaving pot, 204.
 Sheffield, view of (about 1745), frontispiece.

- Shields for engraving.
 Rubbed in silver shield, trays with, 95, 97.
 Soldering in shields, 91.
 Illustrations from catalogues, 90, 412.
- Silver and Sheffield Plate, similar articles made in, 200-1.
- Silver articles made in Sheffield, 190, 200-2, 280, 454, 466.
- Silver detachable parts from plated articles, 462.
- Snuff boxes, 20, 21, 498.
- Snuffers and snuffer trays, 199, 244, 246, 326-8.
 Designs from catalogue (about 1840), 421.
- Soldering, 123.
- Soldering iron used in filling silver mounts, 82; others, 122.
- Soup ladle, 336.
- Soup tureens, 164, 330-1, 389.
- Soy frames, 272, 273.
 Designs from catalogues (about 1778), 404.
- Spinning, 117.
- Spirit bottle, 253.
- Spoons and forks, 336.
 Modern method of manufacture, 337.
- Staffordshire ware mounted by Old Sheffield Platers, 339-40.
- Stamp shop, 104.
- Steak dish, 288.
- Stoneware with mounts, 339-40.
- Strainers, 392, 393, 499.
 Design from catalogue (about 1848), 423.
- Stripping place, 67.
- Sugar basins, 57, 169, 341-3, 466, 498.
 Designs from catalogues (about 1784), 408; (1798), 413.
 Sheffield made silver, 466.
- Sugar castor, 343.
- Sugar crusher, 389.
- Sugar tongs, 336.
- Supper service, 345.
- Swages and swaging, 113, 114, 115.
- Sweet dish, 213.
- Table bell, 389.
- Tankards, beakers, cups and bowls, 150, 346, 347, 348-51, 425.
- Tea caddies and canisters, 85, 177, 187, 352, 353, 498.
- Tea machines, 367.
 Designs from catalogue (about 1802), 416.
- Tea services, 358.
 Design from catalogue (about 1830), 419.
- Tea urn taps, 144.
- Tea urns, 88, 159, 160, 181, 360-6, 379.
 Design from catalogue (about 1782), 407.
- Teapots, 88, 91, 158, 168, 259, 354, 355-7, 499.
 Spout, 144.
- Teaspoons, 336.
- Telescope, small telescope, 390.
- Telescopic candelabra, 238.
- Tinder box, 374.
- Toast racks and trays, 199, 369 370.
- Toasting fork, telescopic, 387.
- Tobacco boxes, 375, 376.
- Toothpick, holder, 163.
- Trays and salvers (or waiters), *see* Salvers.
- Trowels.
 Housekeeping purposes, 388.
 Presentation, 388.
- Tudor, Henry, portrait, 35.
- Vases, 72, 340.
- Vegetable dishes with covers, 288.
- Venison dish wedge, 392.
- Venison dishes and covers, 266.
- Vessel used for mixing drinks, 393.
- Waiters, *see* salvers.
- Warmers for entrée, etc., dishes, 286, 287, 288, 289.
- Warwick vase, articles in form of, 378, 379.
- Watch, 461.
- Wax winders, 251.
- Wearing qualities of Old Sheffield Plate, 180.
- Wedgwood, Josiah, portrait, 193.
- "Winchester Measure," 346.
- Wine coolers, 169, 378, 382-6.
 Silver wine cooler, 382.
- Wine glass cooler, 189.
- Wine glass or tumbler holders, 72, 163.
- Wine labels, 253.
 Designs from catalogue (1770-90), 399.
- Wine strainers, 392, 499.
 Design from catalogue (about 1848), 423.
- Wine wagons, 257-8.

A History of Old Sheffield Plate

INTRODUCTION



OLD Sheffield Plate is the term used to describe articles of flat and hollow-ware for table or domestic use, made of copper coated with silver by fusion; the period of its production dated from near 1743 and lasted for about 100 years; it was then gradually supplanted by electro-plate. In Sheffield plated ware, the silver has been laid upon the copper and the metals united by fusion and hardened and strengthened by pressure between rollers. Unfortunately, as a rule, the extent of the knowledge of the average collectors is that Old Sheffield Plate consists of silvered copper, and they are sometimes therefore induced to buy electro-plated on copper articles when they see the copper exposed to view. These articles are not unfrequently described as "Real Sheffield" and "Sheffield Plate," leaving out the word "Old." Our city, notwithstanding the fact that herein was made almost the whole of the plate in former times, familiarly described to-day as "Old Sheffield," is not, as has often been imagined, an Eldorado where are to be obtained magnificent specimens of the old plated wares in superabundance. There is a time-honoured saying in the city—not without some elements of truth—that good cutlery can be purchased almost anywhere except in Sheffield, and as with the cutler, so with the plater, both sought markets for their wares outside the precincts of his own town. But undoubtedly there is a great deal of Old Sheffield Plate still in Sheffield, mostly in private hands, and carefully preserved by the descendants of those who originally made it for their own use.

At the Sheffield Parish Church will be found an exceptionally large plain Old Sheffield dish or trencher, which is used regularly for carrying the water to the font on the occasion of Baptisms. It is in fine preservation and must have been in use for a considerable number of years. It bears the mark of T. & J. Creswick. The church also contains—amongst other and earlier specimens—some finely-made silver patens and flagons, the latter of a very large size, two of their number manufactured in the reign of Queen Anne, and in beautiful preservation. The plate is well worth inspection by those interested in antique silver.

At the Sheffield Royal Infirmary is a plain communion service in Sheffield Plate presented by Thomas Law & Co. in 1800, consisting of a paten, chalice and flagon, bearing their mark (the squat vase).

That Sheffield is a place of great antiquity from an industrial point of view is established by a reference in Chaucer's "Reves Tale," where the miller is described as follows :—

"A Shefeld thwytel bare he in his hose.

Ronde was his face and camysed was his nose" (*i.e.* snub-nosed).

It is recorded that Edward III. paid a hunting visit to Sheffield, so that the town was not unknown at Court six centuries ago. The population of Sheffield was numbered, in 1615, at 2,207, of which 1,222 were servants and children and 725 "all begging poore." But this is misleading unless we remember that it applies to the Township of Sheffield alone, not to the parish; and that the more substantial inhabitants lived on the outskirts. A more useful comparison is made by taking the figures for the whole parish. These show a population in 1736 of 14,105; in 1801, 45,758; 1841, 110,891; in 1871, 239,941. In 1905, when there had been some extension of the boundaries, it was 440,414, and in 1911 454,653.

Mary Queen of Scots spent about fourteen years of her captivity in Sheffield, between 1571 and 1584, in charge of the Earl of Shrewsbury. At the Manor, Sheffield, now a complete ruin, a small detached building, carefully restored some years ago, still exists; one room therein, which it is presumed was especially reserved for the Queen's use, has beautiful internal decoration, including a finely executed coat of arms of the Shrewsbury family, over the mantelpiece. It is said that this portion of the Manor was especially erected for her by the Earl to prevent escape.

An interesting impression of Sheffield in the early Old Plate period is found in a letter from Horace Walpole to Mr. Montagu, dated 1st September, 1760. The writer says :—

"As I went to Lord Strafford's I passed through Sheffield, which is one of the foulest towns in England, in the most charming situation, where there are 22,000 inhabitants making knives and scissors. They remit eleven thousand pounds a week to London.* One man there has discovered the art of plating copper with silver. I bought a pair of candlesticks for two guineas that are quite pretty."

Among the ancient charities of the city one at least was founded for the benefit of members of the local silver and Sheffield Plate trade. In 1815, Mary Parsons, the sister of John Parsons, of J. Parsons & Co., who were extensive manufacturers of Old Sheffield Plate and silver, principally candlesticks, "from an affectionate regard to her brother's memory," bequeathed a sum of £1,500 on trust for investment, the income to be distributed equally

* This is clearly meant to indicate the value of goods sent from Sheffield to London in one week.

among forty-six old and infirm silversmiths in Sheffield in doles of £1 each, with a gift of £2 to the Vicar for preaching an annual sermon on St. John's day. Augmented by a sum of £175, raised in 1879 by the manufacturers and working silversmiths of Sheffield, the endowment of this charity now amounts to £1,709 17s. 7d. Usually about fifty men receive the annual dole of £1, candidates being selected by the trustees on the recommendation of an annual meeting of working silversmiths. The benefits are confined to braziers, pierce-workers, and candlestick makers who have served their apprenticeship in Sheffield and have regularly worked at their craft. The recipients usually go in procession to church to hear the sermon, after which the dole is distributed in the vestry.

RELICS OF BOULSOVER'S ENTERPRISE IN WHITELEY WOOD, SHEFFIELD.



Dam from which power was derived.



The Workmen's Cottages.



Ruins of Mill below Dam, erected 1762.

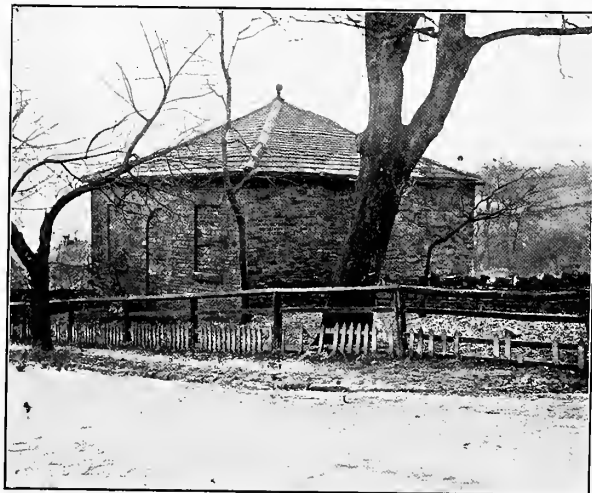

Chapel erected for the workpeople in 1789, after Boulsover's death, now used as a barn (see page 10).

PART I.

THE INVENTION.

OLDEST METHODS OF PLATING.

The methods by which the earliest platers accomplished their work on the larger articles used for ornamental purposes is not very clear. The dominant fact ever to be borne in mind is that, as in the case of electro-plating to-day, the coating of silver was laid on after the articles had been fashioned. The "French" method of plating, previous to the discovery of the process of plating by fusion, consisted of burnishing a beaten leaf of silver at a low heat on to metal before oxidation took place, and although additional leaves could be added, perfect union never ensued. A shell of silver wrapped over the edges of inferior metals had been tried, but this had a tinsel-like appearance and was quite unserviceable.

That from remote times some process of plating baser metals with silver and gold was used by cutlers for the adornment of knives is evident. As early as 1379 the London Cutlers had enacted that silver used for this purpose—"harnessing knife handles"—must be of sterling quality; whilst even earlier still, viz., 1327, letters patent were granted by the London Goldsmiths Company on the complaint that "The cutlers in their workhouses cover tin with silver so subtilely and with such sleight that the same cannot be discerned and severed from the tin, and by that means they sell the tin so covered as fine silver to the great damage and deceit of us and our people."* In the reigns of Henry IV. and Henry V. various Acts of Parliament were passed prohibiting the gilding of any metal but silver, and the silvering of any articles except knights' spurs or articles of nobles' apparel. Probably the same method, handed down through many centuries, is referred to in two of the regulations in the first code of bye-laws promulgated, in 1625, by the Sheffield Cutlers' Company. One of these forbade the use of gold or silver upon the blades, bolsters or hafts of knives of less value than five shillings a dozen; the other decreed that nothing less than sterling silver or gold must be used for damasking, inlaying or studding the knives of higher worth.

* Herbert's "History of the Livery Companies," Vol. II., p. 288.

Defiance of these laws led to litigation and arbitration ; and in an arbitrators' award (1628) we get a clear insight into infringements caused by "counterfeit stuff, whereby any ignorant man or other may be induced to take the same for silver or gold." The bye-law is described as "concerning the mingling of gold with brass, or of silver with tin or pewter to be used or employed in the hatching, damasking, gilding, silvering or other garnishing of hafts, bolsters or blades of knives, or of any part thereof, or in any other cutlery wares whatever."*

It is instructive to note that part of the defence set up by the offenders against these Ordinances was that they were in contravention of one of the Acts before referred to, that of 8 Henry V., cap. 3 (1420), and it will be seen hereafter that it was (in all probability) the undertaking of repairs to just a knife of the kind referred to in this dispute that was instrumental in revealing to Thomas Boulsover the possibilities of plating by fusion—in other words, in leading to the invention of Sheffield Plate.

The above references to the earlier use of silver and gold for plating and ornamenting purposes in England bring us naturally to the question, How were these blades and hafts of knives formerly plated? Certainly not by any process lacking in durability or incapable of bearing the rough usage incidental to articles in constant everyday wear. We must look to what is called "close plating," in some form or another, as answering our question. That is the only system by which steel or iron, even to-day, in any permanent manner and with entire satisfaction, can be coated with silver. Close plating has been so persistently associated, and constantly confused with plating by fusion that a clear explanation of the former will not here be found out of place.

Practically any metal that can be soldered is capable also of being close plated. But the process is laborious, and is usually only applied to the smaller articles in daily use that need greater resisting power than ordinary hollow-ware or require the possession of a cutting edge, e.g., knife blades and snuffers ; or of pointed or sharp ends, as forks, skewers, cheese scoops, lobster picks ; or of strength, as in the case of bridle bits, spurs, harness fittings and carriage door handles.

* For further particulars as to these facts see Leader's "History of the Sheffield Cutlers' Company," Vol. I., pp. 12, 53, 54 ; Vol. II., pp. 25, 26.

PROCESS OF CLOSE PLATING.

Although close plating, as carried out both formerly and to-day, is entirely simple in its main features, expert skill of manipulation can only be attained by the greatest patience and maintained by constant practice. The process may be described as follows :—Having first been made perfectly smooth and clean, the article to be plated is then, to ensure complete adhesion of the substance to be deposited, dipped into sal ammoniac, which acts as a flux, and is afterwards dipped into melted tin. A foil of silver, having been beaten thin and cut to the required size, is now placed upon the article and fitted as evenly and perfectly as possible. After the silver foil has been closed upon the steel in every part by pressure, a heated soldering iron is lightly passed over the whole of the surface. By this operation the tin is melted and forms a solder between the steel and the silver covering. The surface is now carefully smoothed all over with a heated soldering iron, then, the fash having been carefully clipped away and the edges laid down with a burnish, it is ready for finishing off by hand or by the aid of machine polishing, as is customary with all articles, whether plated or silver.

This process of close plating, which we must regard as the fore-runner of the equally permanent process of plating by fusion, barely held its ground after the latter had come into general use. For it was helpless to prevent its new competitor from gradually monopolising the production of household wares of a receptive and ornamental character. The process of close plating seems to have been so effectually supplanted by its more formidable rival, fused plating, that we have to wait until the early part of the 19th century before, after some years of effort, it regained recognition. At least two improved patents had been taken out in the 18th century for close plating, one by Samuel Roberts, adapted for turning out spoons and forks from iron “or any compound or white metal,” and also for making candlesticks from the same materials. His patent reads remarkably like a determined attempt to resuscitate close plating by testing its possibilities for articles in daily requisition of both a useful and ornamental character. But these products were not a success, being too heavy in use. They were also liable to rust. In the year 1779, ten years previous to Roberts’ improved patent, another patent had been taken out by a London jeweller, Richard Ellis, who significantly refers to his process as being a “new mode” (i.e., presumably an improvement in close plating). A perusal of the description of his patent brings one to the conclusion that it refers to the ingredients of the solder used when performing his method of close plating. But here,

as in Roberts' case, the obscurity of the wording almost suggests that, intelligible as the process may have been to the inventors themselves, the desire was rather to confuse the reader than to make plain what was doubtless the result of much thought and careful research. Little was heard subsequently of either, and during all the period of the Sheffield Plate industry, the only means by which this earlier process was kept from entire extinction was its adaptation for the cutting blades and handles of snuffers, adornment of steel buckles, and its employment by the cutlers for the blades of knives. The permanency of close plated articles is dependent on their not being exposed to undue heat or moisture. The blade of a knife or fork plated by this method, if held for a moment in a flame quickly sheds its coating of silver, whilst in a damp atmosphere the metal underneath is liable to rust, and consequently the silver blisters.

Sir Edward Thomason (of Birmingham), in his "Memoirs of Half a Century," vol. I, p. 36, throws some interesting light on the subject of close plating and its revival in the early parts of the 19th century. His remarks are as follows :—

In the beginning of January, 1810, I increased my manufacturing rooms to add a new trade—the plating upon steel, of knives, forks, spoons, &c. There being an idea at this period that there was no affinity between steel and silver, and a medium must be found that would unite with or have an affinity for both. This medium was tin, a thing known before but not acted upon so scientifically as it might have been. I succeeded, and my manufactures in this novel line were appreciated by the public, as the following letter dated 26th Feb., 1810, Northumberland House, and signed "Percy," will prove :—

"SIR,

Northumberland House, 26th Feb., 1810.

"Having mentioned your plated steel knives and forks, spoons, and plates in imitation of silver, to a gentleman who is soon to set off for a country where there is much difficulty in procuring earthenware, he is very desirous of taking some out with him. I will be much obliged to you, therefore, to send me, as soon as possible, one dozen of each, with the bill for them, as I should hope that you have, by this time, succeeded in coining plates. Should there, however, be any shop in town to which you send your goods, it would, perhaps, be better to refer me to that shop, instead of sending the things from Birmingham, as I could see a greater variety to choose out of. I am anxious, Sir, to know whether you lately produced any new inventions, and, also, whether you have been able to convert the Japan leather to any use. Should the Club which you mentioned to me when I was in Birmingham publish their dissertations or lectures, I should wish very much to see them.

"I remain,

"Your obedient Servant,

"E. Thomason, Esq., Church Street, Birmingham.

"PERCY."

I daresay that the new manufacture occupied much of my spare time during this year, to see what class of articles could be made to answer ; and it appeared that this mode of plating was confined to small articles, and the dinner plates to which the noble Earl Percy alludes, could not be properly accomplished."

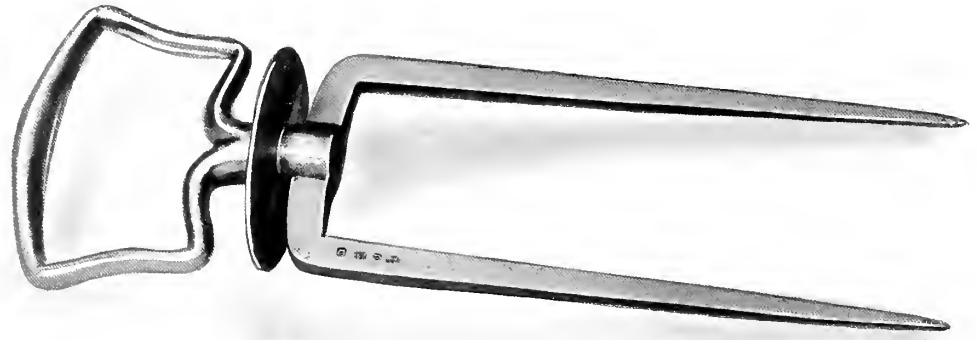

Close plated Meat Fork, $9\frac{1}{2}$ in. long, engraved with the Cutlers' Co.'s Arms, by W. Hutton, Sheffield.
Date 1837. Cutlers' Co., Sheffield.



Date 1812.] Close plated long shade Candlestick Snuffers, $9\frac{1}{2}$ in. long, by Allport, Birmingham [Author.

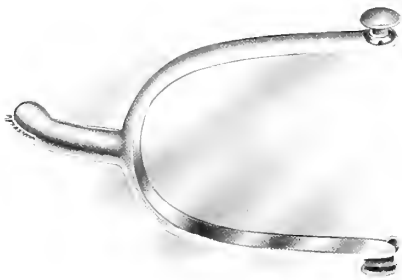

Close plated Spur, $5\frac{1}{2}$ in. long.
Date 1825. Author.

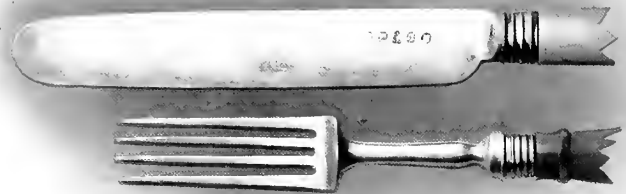

Close plated Dessert Knife and Fork, by A. Hadfield, Sheffield.
Date 1808. Author.

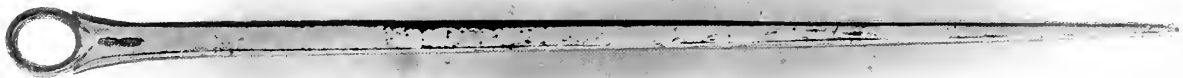

Date 1807. Close plated 14 in. Skewer, by J. Linwood, Birmingham. Miss Bradbury, Sheffield.

ILLUSTRATIONS OF VARIOUS ARTICLES USUALLY DESCRIBED AS "CLOSE PLATED."

BOULSOVER'S DISCOVERY OF PLATING BY FUSION.

Disappointingly vague and unsatisfying are the accounts handed down to us of the manner in which Thomas Boulsover,* hitting upon heretofore unrecognised metal affinities, laid the foundations of Old Sheffield Plate. The tradition is that in 1743, when following his occupation as cutler and engaged in the prosaic repair of a knife haft, the behaviour of the silver and copper used in the ornamentation arrested his attention. What was it that he saw? To this question the chroniclers give diverse answers. Hunter,† avoiding detail, simply says that, the knife handle being composed partly of silver and partly of copper, Boulsover was "struck" with the possibility of uniting the two metals. Others, more specific, allege this combination to have actually occurred under Boulsover's eyes, being brought about (1) by the fusion, through accidental overheating, of the silver and copper in the haft; or (2) by the silver so fused adhering firmly to the copper of a penny which he happened to have stuck into the vice as a wedge. Another version dwells rather on a consequent event—the discovery that the metals, having become united, retained in combination under pressure all the ductility possessed by them separately and acted as one in response to manipulation. It was this, the statement continues, which surprised Boulsover when, desiring to spread out the silver so as to cover a bare spot, he put the knife haft "through the rollers," and found that instead of the silver expanding alone, silver and copper together elongated in complete unison.‡

That this, and not adhesion by fusion, was the vital discovery, seems an irresistible conclusion. By subjecting an old copper penny and a sixpenny piece to the flame of a blowpipe, anyone can with ease crudely demonstrate the part fusion plays in the making of Old Sheffield Plate. And he will find it impossible to believe that, with soldering in common use, it was left for Boulsover to be, in 1743, the first to bring a blowpipe to bear on silver and copper. It may be, however, as has been suggested, that the commercial

* We must conclude that the hitherto accepted version of the spelling of the name "Bolsover" is incorrect. Mr. J. B. Mitchell-Withers says, "As far as any evidence I know of, originally the name was spelt with the 'u,' and the book I have in which the signature would apparently be written by Boulsover it is 'Thomas Boulsover.'" It is also spelt so in the letter published in the "Sheffield Mercury" in 1840, and it is also so spelt in the pedigree showing the claims of Benjamin Blonk Silcock, and I believe I have seen his daughter's name spelt with the "u." Without unduly multiplying confirmations these may be cited: the record of burial in 1788 as "Thomas Boulsover;" entry in the Ecclesall Bierlow Rate Book of 1786, ("Thomas Boulsover"); and finally from the old ledgers of Thomas Bradbury & Sons, the records of the name of Boulsover's firm therein in the years 1778-79-80-81-82, being "Thomas Boulsover & Co."

† Hunter's History of Hallamshire, 1819 Edition, Page 124.

‡ Experiment has proved that when a strip of silver is close-plated (or soldered) on to a like-sized piece of copper, the two metals behave under pressure of the rollers in an exactly similar way to fused plate, *i.e.*, they elongate indefinitely in conjunction; the same results are obtained in the case of tin plated with silver.

importance of this had not "struck" anyone before him, and only became enlightening in combination with the discovery that the joined metals were completely homogeneous and workable. Notwithstanding an element of suspicion aroused by the fortuitous presence of convenient rollers, not usual adjuncts of a cutlers' shop, it seems possible that this was the real discovery.

It is at least very unlikely that he should have the luck to be favoured by two simultaneous "accidents," the one revealing the feasibility of plating by fusion, the other that the united metals could be lengthened indefinitely under pressure. But in the absence of any explanation by Boulsover himself, and of any strictly contemporary narration, it must be admitted that all this is conjecture. A balancing of probabilities does little to resolve the mystery of what actually happened in Boulsover's garret. Perhaps, after all, there was a certain combination of intelligent search, good luck, and what, in homely phrase, is called the power to put two and two together.* Other businesses that he founded in after life, such as the establishment of rolling mills, manufacture of saws (by the new process of rolling), spades, shovels, etc., should, one would have thought, have handed his memory down to us to-day as one of the greatest pioneers of the 18th century commercial industries.

It is said that the old process of saw making involved the laborious method of beating out the blade from a bar of steel. Boulsover is credited with the merit of having substituted for this process the simpler one of rolling, the advantages of which his silver plating experience had made him familiar with. He also introduced the ingenious but then novel method of so setting saws' teeth as to give "gait" without the clumsy primal plan of keeping the cutting edge of the blade thicker than the back. It was for this industry that he erected works on the stream below his house at Whiteley Wood—beginning, as he said, with a purse that had no neck and ending with one that was all neck. The workmen's cottages are still to be seen at Bowser (that is Boulsover) Bottom, but traces of the mills, not long ago very manifest, are now almost destroyed. There remains, however, the dam which supplied water power. Shortly after Boulsover's death, his daughter, Mrs. Hutton, built a little chapel for the workpeople between the mills and the Hall. It still stands, used as a barn, as part of Mason's farm (see illustrations, page 3).

* It is a significant fact, despite attempts in some quarters to represent it as a "re-discovery," that not only in England is the credit of the discovery of the process of plating by fusion given to Boulsover, but he is the generally accepted originator of this method where plated metals are in use throughout the whole world.

DESCRIPTION OF THE PROCESS.

Boulsover's method of plating by fusion is still carried on to-day, and we cannot do better than detail the description given by Mr. William Adcock Ellis, whose firm have been employed constantly on this process for upwards of a century. Mr. Ellis has also kindly supplied the copper ingots here illustrated. It should be noted that the modern procedure differs only in certain slight details from the methods adopted in the earliest years of the industry.

“About a century ago, when the trade in Old Sheffield Plate was at its height, it was found that the most reliable metal to be plated upon suitable for rolling into sheets was copper slightly alloyed with zinc and lead, this mixture having been discovered by experiment to produce a metal easily workable, neither too hard nor too porous, whilst the silver coating was slightly alloyed with copper in the same proportion as standard silver (i.e., 925 parts of pure silver to 75 parts of alloy).

An ingot of the above metal, varying from $1\frac{1}{2}$ " to $1\frac{3}{4}$ " thick, and $2\frac{1}{2}$ " wide by 8" long, or of larger dimensions, according to the weight and size of the plated sheet required to be made, was taken, and the surface (or both surfaces when plating on both sides of the ingot) was planed to take the casting inequalities off, by which means a solid surface was obtained. The ingot was then filed and scraped until all imperfections on its face had vanished. The sheet of silver was now cut to nearly the size of the face of the ingot of copper, and of a gauge of the quality of plate required,* after being treated in a similar manner to the copper ingot. The two prepared surfaces were then placed together, great care being taken that no dirt or moisture was allowed to remain on the surfaces; these were then firmly pressed together so that the two faces fitted quite evenly. To-day, this process of pressing to expel all particles of air, before fusing, is performed under a powerful hydraulic press; formerly it was accomplished by one man holding a piece of iron about 20lbs. in weight called a 'bedder,' whilst a second struck it with a heavy hammer. This flattened the two surfaces, embedding the silver into the copper.

A copper plate, dressed with a solution of chalk to prevent it from adhering to the silver, was then placed on the silver to protect it from the fire. The three pieces of metal (or in the case of double plated metal, i.e., both sides being silvered, the five pieces of metal) were bound together with iron

* The gauges varied very considerably at different periods, bearing in mind the various purposes for which the sheets of metal were desired to be used, a very good quality of metal having quite one-eighth of an inch of silver deposited on to an ingot such as is described above.

wire, the edges where the silver and copper came in contact were then dressed with a solution of borax. The ingot was now ready for the fusing process and deposited in a furnace heated with a coke fire, upon which it was placed, being most carefully watched through a small hole in the furnace door until the sheet of silver on the copper ingot began to 'weep' (as the technical term is) i.e., commenced to trickle down the sides of the ingot. The time had now arrived for its extraction from the oven and great care had to be taken in the removal. Suitable tongs were used for clasping the ingot firmly by the sides and holding it quite steady whilst being removed. Finally, the ingot, after sufficient time had elapsed for it to cool, and before sending it to the rolling mills, was carefully cleansed by dipping it in acids and afterwards scouring it with sand and water.

Should any blemishes appear on the plate after the rolling process, a section of the sheet could be cut out and discarded, or the method of 'French plating,' described on page 96, could be turned to as an alternative ; but the time occupied by this process being of more value than the small section of material made waste, there was little inducement to use it."

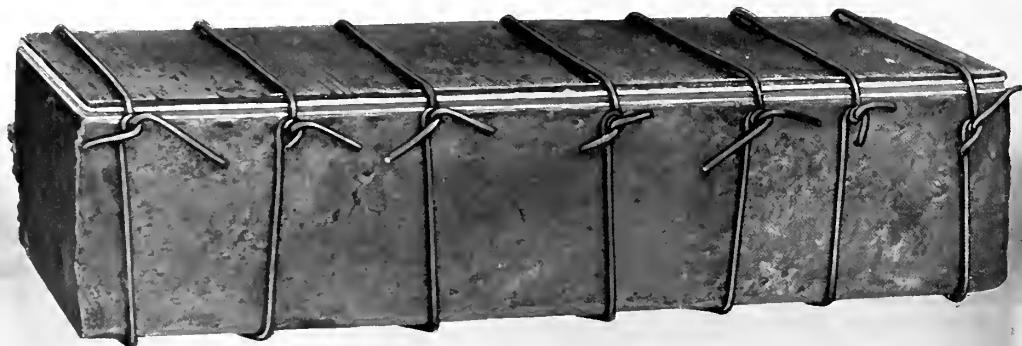

Copper Ingot, with silver sheet laid on, preparatory to the process of plating by fusion. About two-thirds of actual size.

Regarding the question whether in former times plating on four sides of the ingot was ever undertaken, experiment has proved that, by facing up all four sides of an ingot with silver and chalk covered copper plates, sufficient heat cannot be conducted to the interior to bring the copper to the necessary temperature for fusion.

When plating two faces of the ingot only, two sides of the copper surfaces being exposed to the furnace, the heat required is readily attained.

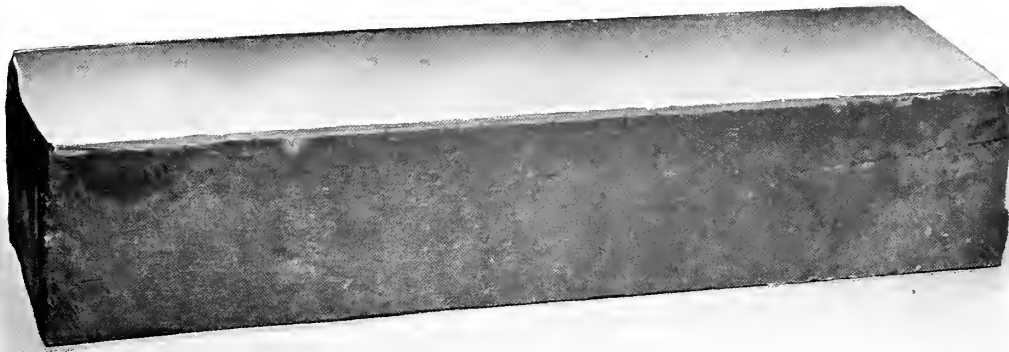

Copper Ingot after the process of plating by fusion. The edges have been trimmed preparatory to being rolled

TO WHAT PURPOSES THE INVENTION OF FUSED PLATE WAS FIRST APPLIED
AND HOW THE TWO PIONEERS SUBSEQUENTLY FOLLOWED OTHER
INDUSTRIAL UNDERTAKINGS.

Some extremely interesting sidelights on the Old Sheffield Plate industry are furnished by manuscripts left by Charles Dixon, a candlestick maker, who was born in Sheffield in 1776 and died in 1852. For some years prior to his death he expended a vast amount of industry in compiling a record of incidents, anecdotes and movements of the times in which he lived, and as he mixed freely with men who were then engaged in the manufacture of Old Sheffield Plate, his recollections bearing on this subject are of such importance as to deserve reproduction in the writer's own quaint phraseology:—

“A person of the name of Thomas Bouisover was the discoverer of the art of plating copper with silver. He was by trade a cutler. In the year 1743 he had some work on hand whereby the back of the knife was covered with silver soldered on it. Finding that he was short of silver, he put the whole of it, just as it was, through the rollers at the hazard, and found that the hard and soft lengthened together, which made him reflect on cause and effect.

NOTE.—The patent taken out by the late Mr. J. Devonshire Ellis, for so long chairman and managing director of Messrs. John Brown & Co. Ltd., of this city, for the now superseded but formerly universally adopted composite armour plating, owes its origin to the idea of fused silver plate! The late Sir J. Brown, the founder of this business, was in the year 1841 appointed as agent in Sheffield to Mr. Ellis' father's firm, Messrs. Charles Ellis & Sons, of Birmingham, for the sale of their metals, which firm to this day still carry on this selfsame business as manufacturers of fused silver plated sheets, as well as German silver and every kind of rolled metal and wire that is required by the plated trade for all practical purposes. (This firm must not be confused with any of the local Birmingham manufacturers of “made-up articles of hollow-ware” existing to-day.)

*Boulsover then began to experiment. He found that silver melted sooner than copper, and lay upon the surface of the copper in a fluid state, so that when heat had been applied long enough to melt the silver, it and the copper became one solid body,† and was capable of being rolled down to any size or thickness.

The first use Mr. Boulsover made of his discovery was the making of plated buttons, which seemed to answer very well. The discovery of plating being his own, he kept it a secret, and for a great length of time he had no opposition in his trade.

The buttons he cut out under the fly with a bed and a punch, hard-soldered on the shank, and afterwards polished and burnished them. The greatest difficulty he had to encounter was the need of money to extend his trade with. He had little or no capital, and up to this time what he earned was from the produce of his own hand labour.

Mr. Pegge, of Beauchief,‡ who had some knowledge of Mr. Boulsover and his family, was the person he resolved to apply to for assistance. Being received with courtesy, he explained to him the nature of his difficulties, showing him his patterns, and giving him particulars of the prospects of the sale of his buttons. Mr. Pegge saw the feasibility of the speculation and lent him £70, wishing him success. At the end of twelve months Mr. Boulsover waited upon Mr. Pegge again. Mr. Pegge says, "Well, Thomas, how are you? What, are you come to borrow some more money?" "No, sir," was the reply. "I am come to pay you what money I have borrowed of you with the interest upon it." "Thou art, Thomas?" "I am, sir." "Well, Thomas, I don't wish thee to injure thy trade to pay me. I don't want the money if it will do thee any good a little longer; don't pay me if you cannot conveniently spare it." "Oh, yes, sir, I can spare it; and I have plenty of money besides to carry on my business with." "Why, Thomas, thy trade must be as good as making money." "Yes, sir; but it is a deal better than making money, for I can sell my buttons readily for a guinea a dozen, and the silver does not cost more than 3s. a dozen: so it costs more to make money than they do.

He paid Mr. Pegge and thanked him. He was very successful with his buttons, and by ornamenting them he had a great variety of patterns. When he had been in business some time he sent the sweepings, which he had taken great care of, to Mr. Read's, refiner, in Green Lane, and in a little time they sent him back £100 worth of silver—so much for the value of shop sweepings."

The above shows that after some experimenting, Boulsover had applied his invention to the manufacture of buttons, and some other small wares which had previously been made of silver alone. It was Joseph Hancock (of whom more hereafter), who realised the wider commercial possibilities of the new process, and he applied it to a more numerous range of goods, at first making saucepans, then coffee pots, hot water jugs and candlesticks, &c.

The late Thomas Nicholson records a story that Boulsover was very badly treated by a representative whom he employed in the early days of his invention. Engaged to call upon Boulsover's customers, this individual

* The author has ventured here to alter slightly the sequence of Mr. Dixon's notes, otherwise it would seem as though in one or two small details he had inadvertently placed a cart before a horse. He spells the name Bolsover.

† The melting point of silver is 962 and of copper 1084 centigrade.

‡ Strelley Pegge, of Beauchief Hall, Esquire, ancestor of the Pegge-Burnells, of Beauchief Hall, Derbyshire, owner of Whiteley Wood, where Boulsover afterwards resided.

passed many of the orders he received to a confederate in Sheffield, while representing to his employer that he could do no business for him, as no one believed in the new process. However this may be, Boulsover chiefly devoted himself to other enterprises, in which he expended a good deal of unremunerative capital, whilst wealth was subsequently built up by those who confined themselves to the production of the plated ware. After about fifteen years expended on manufacturing, Joseph Hancock left the making of finished goods and devoted himself to the business of rolling metal for the manufacturers. The date of this transference we may fix as between the years 1762-1765, and about the same time that Boulsover took to the making of saws, etc. Originally the metals were beaten out into sheets by hand labour on the premises, having first of all been fused there. Later on they were rolled by hand power (and, about the time that Joseph Hancock started rolling metal for the trade) horse and water power followed. Eventually steam was employed to drive the mills.

What has been said above explains why, in the quotation from the old Directories given on subsequent pages, neither in 1774 nor in 1787 is Boulsover or Hancock included in the category of silver platers. In the earlier, Boulsover appears in this form, "Boulsover, Tho. & Co., Manufacturers of Saws, Fenders, Edge Tools, Casted and Emory, Sycamore Street"; the only Joseph Hancock mentioned being "Hancock Joseph, Cutler, Norfolk Street." Boulsover is not mentioned in the 1787 Directory, where Joseph Hancock is described as "plated metal roller, Union Street." There is good reason to believe that earlier (circa 1771) he had been engaged in the same industry in High Street, on or near the site afterwards occupied by William Hutton & Sons' silver plate works, now the premises of Newsome, chemist. He established the Old Park Silver Mill, still in existence, in Club Mill Road, Hill Foot, substituting there water for horse power for rolling plated metal.

The books of Thomas Bradbury & Sons show that Hancock was rolling plate for their predecessors in the years 1783-1787—

DR.				MR. JOSEPH HANCOCK, SHEFFIELD—CONTRA—				CR.					
1783.				£	s.	d.	1783.				£	s.	d.
Aug. 9.	To Cash	5	5	0	June 24,						
Sep. 13.	"	5	5	0	By Balance from O.L., p. 244	..	176	15	4		
Nov. 1.	"	5	5	0	By Rolling as p. bill in 1783	..	73	10	6		
Dec. 20.	"	5	5	0	" " 1784	..	65	12	6		
1784.							" " 1785	..	58	12	2½		
Feb. 17.	"	5	5	0	" " 1786	..	56	6	7		
May 29.	"	5	5	0	" " 1787	..	30	14	8½		
Aug. 21.	"	5	5	0							

There are also in the same ledger entries relating to Boulsover, as having been a purchaser of goods from the same firm (M. Fenton & Co.) in the years 1778-79-80-81-82.

THE NEW INDUSTRY AND ITS POSSIBILITIES.

As a result of the discoveries of Boulsover, supplemented by those of Hancock, a new and important branch became quickly grafted on to the already existing cutlery industry. There was, naturally, a short initial or tentative stage, in which, in the hands of the inventor, the new process was on its probation, and under the necessity of justifying its capabilities. Mr. Leader, in his "History of the Cutlers' Company," does not endorse the view that the fact of Boulsover confining his manufacture of plated goods to buttons, snuff boxes, and other light and small wares, shows that he did not immediately realise the possibilities of his discovery. He inclines to the opinion that Boulsover wisely sought, at the beginning, to demonstrate the value of the process by the practical application of it to the articles on which Sheffield's industry was chiefly engaged. And among these there were not only cutlery wares, the scope for ingenuity in which is seen by the large number of "silver cutlers" who speedily utilised the new material, but there were also ready at hand, admirably adapted for experiment, minor manufactures which may be said to be almost indigenous to the place, and for whose products there was a ready market. Button-making, for instance, became important enough early in the 18th century to justify the Cutlers' Company joining in a long and costly defence of this trade, although it was outside the jurisdiction of this guild. The fight in question was on behalf of the makers of uncovered buttons, and the result left them free to pursue their avocation without molestation under old statutes passed in the interests of textile-covered button fabricators. This victory came shortly before Boulsover's discovery, which thus dawned upon a local trade in full swing. Manufacturing not only horn buttons, but buttons possibly of silver and certainly of the baser metals, such as brass and an amalgam known as "alcomy" (said to have a resemblance to gold), the suitability of the new process for enlarging an already existing trade would be at once obvious in many a Sheffield workshop. Its adaptation did not eliminate the cheaper buttons from the garments of the humble, nor did plated ware supersede silver buttons. But it supplied the wants of an intermediate class, who were ready to assume the semblance of a precious metal though they had it not.

BUTTONS.

It is noteworthy that the plated button, the very first article to be made by Boulsover, should have held its place amongst the many productions from fused plated metal more tenaciously than any other experimental articles.

Through the courtesy of Messrs. Firmin & Sons, of London, the author is able to illustrate on the next page specimens of buttons made from fused copper plate, some of them struck up from dies that have been in existence since the reign of Queen Anne (in those days probably used for stamping silver buttons).

Messrs. Firmin are perhaps the oldest extant firm of button makers in this country; their business can be traced back to the year 1702 and it was undoubtedly in existence before that date. The method of producing these buttons has not materially altered in its main features since the days in which Boulsover manipulated them by the aid of a bed and punch. Messrs. Firmin state that copper-plated buttons for uniforms and liveries are as extensively made of fused plated metal to-day as ever previously, and that since the discovery of the process this method has been continuously and systematically carried on at their factory. Buttons plated by electro deposition cannot stand the hard wear and tear of actual use.

(An interesting advertisement from a Dublin paper, "Faulkener's Journal," February 24th, 1747, reads: "John Roche, Usher's Quay, Dublin, makes gilt, silvered and plated buttons.")

BOXES.

Box-making was also an old Sheffield industry too profitable to be despised, and ripe for such an enlargement as Boulsover's discovery brought. In 1680 the Cutlers' Company, constituting itself a middle-man between producer and consumer, established a storehouse into which it received goods and undertook their distribution on behalf of the makers, and the records of the transactions show that (besides cutlery) tobacco, snuff and money boxes, made by Freeman of the Company (including one Isaac Hancock), were lodged with the Company and were sold in considerable quantities to merchants.* So profitable did the business appear that when at a later period the Cutlers' Company was betrayed into misguided manufacturing zeal on its own account,

* In 1671 a certain Maurice Brownhill, when taking Jack Hancock as an apprentice, covenanted to teach him to make tobacco boxes

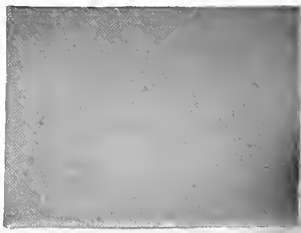

Fused Metal Sheet before Button is stamped.



Button after stamping from die.



Button after cutting out and ready for mounting.



Earl Digby Button.
Die cut 1700.



H.M.S. Exmouth Button.
Die cut about 1730.



Marchioness of Winchester Button. Date uncertain.



Marchioness of Wellington Button. Die cut 1846.



Dowager Duchess of Norfolk Button. Die cut 1858.



Duchess of Grafton Button. Die cut 1864.



Fused Plated Button, 1870.



Fused Plated Button, 1790.



Fused Plated Button, 1875.



Fused Plated Button, small size, 1875.



Fused Plated Button, 1880.



Fused Plated Button, 1885.



Fused Plated Button, 1890.

ILLUSTRATIONS OF VARIOUS KINDS OF BUTTONS MADE FROM FUSED PLATED METAL.

among its enterprises was setting up a box trade.* This episode is not only interesting in itself, but is germane to the history of Old Sheffield Plate, because Thomas Law, one of the earliest platers, took an active part in the management, procuring the materials necessary for and perhaps even making the boxes. This speculation was, however, very short-lived, and Law eventually bought part of the tools and utensils, while the stock which had accumulated was despatched to London for sale. There is, unfortunately, nothing to show whether this launching into the industry marks an eagerness on the part of the Cutlers' Company to share in the benefits of Boulsover's invention, then some six or seven years old, or whether the boxes were of the kind made in 1680—of iron and perhaps brass, whose lids were etched or "written" with designs or lettering.

Boxes for snuff in all sizes were amongst the very first things to which the old platers turned their attention. Boulsover and Hancock both manufactured these small boxes, usually with lids that pull off, and are not hinged. As the plating industry developed, the Sheffield manufacturers concentrated their efforts on larger articles, and although box making was still carried on in the town when Sketchley's Directory of 1774 was published, the trade gradually drifted into a branch of Birmingham jewellery. Some tiny surviving examples were obviously for use as patch boxes; others are found just large enough to contain four George III. shillings.

The choicest specimens were those of which a few illustrations are given on two subsequent pages, with lids and bases ornamented in low relief. The lids not infrequently show evidence of being chased by hand; others have been struck up from finely cut steel dies. The source of origin of the boxes here depicted is uncertain; the date of their manufacture is approximately between the years 1750-1765. The lids, made separately, are clipped round and fastened on to the upper surface of the boxes by lapping over the sides to secure them firmly, and to make them more serviceable a loose sheet of unplated copper is secured underneath the lids. The bottoms are fastened in by the same methods, the sides swaged in strips and soldered together, the seams being clearly visible. The insides of the boxes are not tinned as was usual with Sheffield-made articles, and reveal the bare copper on removing the lids. Some collectors attribute the manufacture of these boxes to the French. It is perhaps possible that the lids, which often portray classical subjects,

* Cutlers' Company's History, vol. 1, pp. 163, 173-4.



Snuff Box, with lid struck from a die—no hinge—
2 $\frac{3}{4}$ in. diam. \times $\frac{3}{4}$ in. high.
Date 1750—1760. Author.



Reverse of the same box, showing decoration, also
struck from a die.



Snuff Box, with lid hand chased, and aventurine
composition intended to resemble clouds—no hinge—
2 $\frac{3}{4}$ in. \times $\frac{3}{4}$ in.
Date 1750—1760. Author.



Reverse of the same box, showing decoration, struck
from a die.



Snuff Box, with lid hand chased, and aventurine
composition intended to resemble clouds—no hinge—
1 $\frac{3}{4}$ in. \times $\frac{3}{8}$ in.
Date 1750—1760. Author.



Reverse of the same box, showing under side of a
serrated tortoiseshell pattern.

ILLUSTRATIONS OF VARIOUS FORMS OF SNUFF BOXES MADE FROM FUSED PLATED METAL.

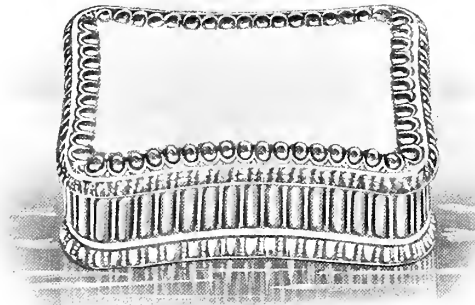

Obverse and reverse of Patch Box, with lid struck from die—no hinge—inside a steel mirror, 1 in. \times $\frac{3}{8}$ in., under side of tortoiseshell.

Oblong hand fluted shaped sided Snuff Box, tinned inside, 3 in. \times 1 in.

Date 1750—1760.

Author.

Date 1770.

Withers, Leicester.



Obverse and reverse of mercurial gilt Snuff Box, with copper foundation. The lid and sides hand chased in high relief, 2 $\frac{3}{4}$ in. \times 1 in. Reverse side struck from a die (same die has also been used when decorating reverse side of round box shown on opposite page).

Date 1750—1760.

Ince, Newport.

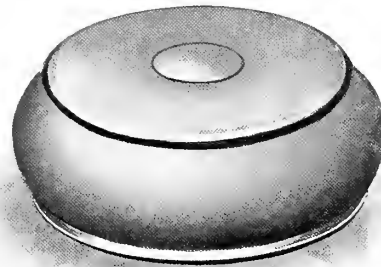

Oblong Snuff Box, 3 $\frac{3}{8}$ in. \times 1 in. high.
By Tudor & Leader.

Round Snuff Box, with pull off top, tinned inside,
2 $\frac{3}{8}$ in. \times $\frac{5}{8}$ in.

Date 1800.

Mr. R. E. Leader.

Date 1805.

Author.

may have been imported by the Sheffield makers and then made up. Still, as these boxes sometimes bear typical English characters and lettering in English, they are most probably of home make, though at first sight presenting a somewhat foreign appearance. Also, being usually made with pull-off tops, it is likely that they are early specimens of the fused plate industry of Sheffield.

BUCKLES.

It is impossible to concur in the opinion of most writers on Old Sheffield Plate that shoe buckles were prominent among the articles to whose productions the pioneers of plating by fusion turned their attention. Buckles in parts plated were known from the time about 1659, when they became fashionable. Specimens of these are to-day to be found in collections, but the process by which they were plated is too obscure to justify any confident statement as to its precise nature. It is obvious, however, that the workman who could make and adorn knife handles with silver could just as easily treat buckles in the same way. And when we turn to examples of the buckles of Boulsover's period we find them for the most part close plated,* though there are others of solid silver, of plain steel or iron, of gilded brass, of pinch-beck, and other cheap kinds of combined metals. Fusion plated buckles are indeed conspicuously absent, and this because their manufacture presented three difficulties. Firstly, the copper foundation would be rather too soft and pliable to stand rough usage; secondly, to get the necessary thickness on the bridge and the tapering towards the ends, infinite and careful hammering would be required; and thirdly, the cutting-out process, would expose great raw stretches of bare copper on the insides difficult of manipulation for the purposes of side plating. And beyond this, there is also to be remembered the fact that the soft soldering of much delicate ornamentation on to such small articles could not be so carried out as sufficiently to ensure adequate durability. Very rarely gold plated buckles with a copper foundation are met with, but the fabrication of these, involving extremely delicate handling, must have been costly. Mr. S. Mitchell, giving in 1840 a list of articles manufactured by Thomas Boulsover, makes no mention of the plated buckles so often attributed by others to his ancestor.

* It is significant, too, that Sketchley, in his list of 1774, mentions buckles along with bridle bits, stirrups and spurs, articles that were invariably close plated.



Obverse and reverse of Boulton & Smith's patent Buckle, with fused plated die struck decoration. Author. Date 1795.



Close Plated Steel Buckle, chased decoration. Author. Dated 1785.



Buckle made from Tutania metal, with "Boulton's patent fastener." Author. Date 1780.



Solid Silver "cut diamond" Buckle, hall marked in London. Author. Date 1790.

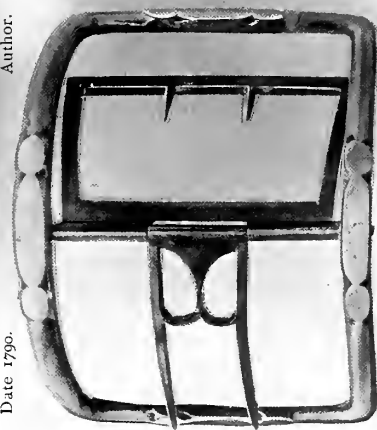

Large close plated steel Buckle. Author. Date 1800.



Buckle, gilt on brass, with "Dadley's patent fastener." Author. Date 1803.



Britannia Metal Buckle, silver plated and pierced. Author. Date 1795.



Buckle with mounts struck from fused plate, by Boulton & Smith. Author. Date 1805.



Large Buckle, with thin silver mounts and "Boulton's patent fastener." Author. Date 1800.

ILLUSTRATIONS OF VARIOUS FORMS OF BUCKLES, MADE FROM DIFFERENT METALS, BETWEEN THE YEARS 1780—1805.

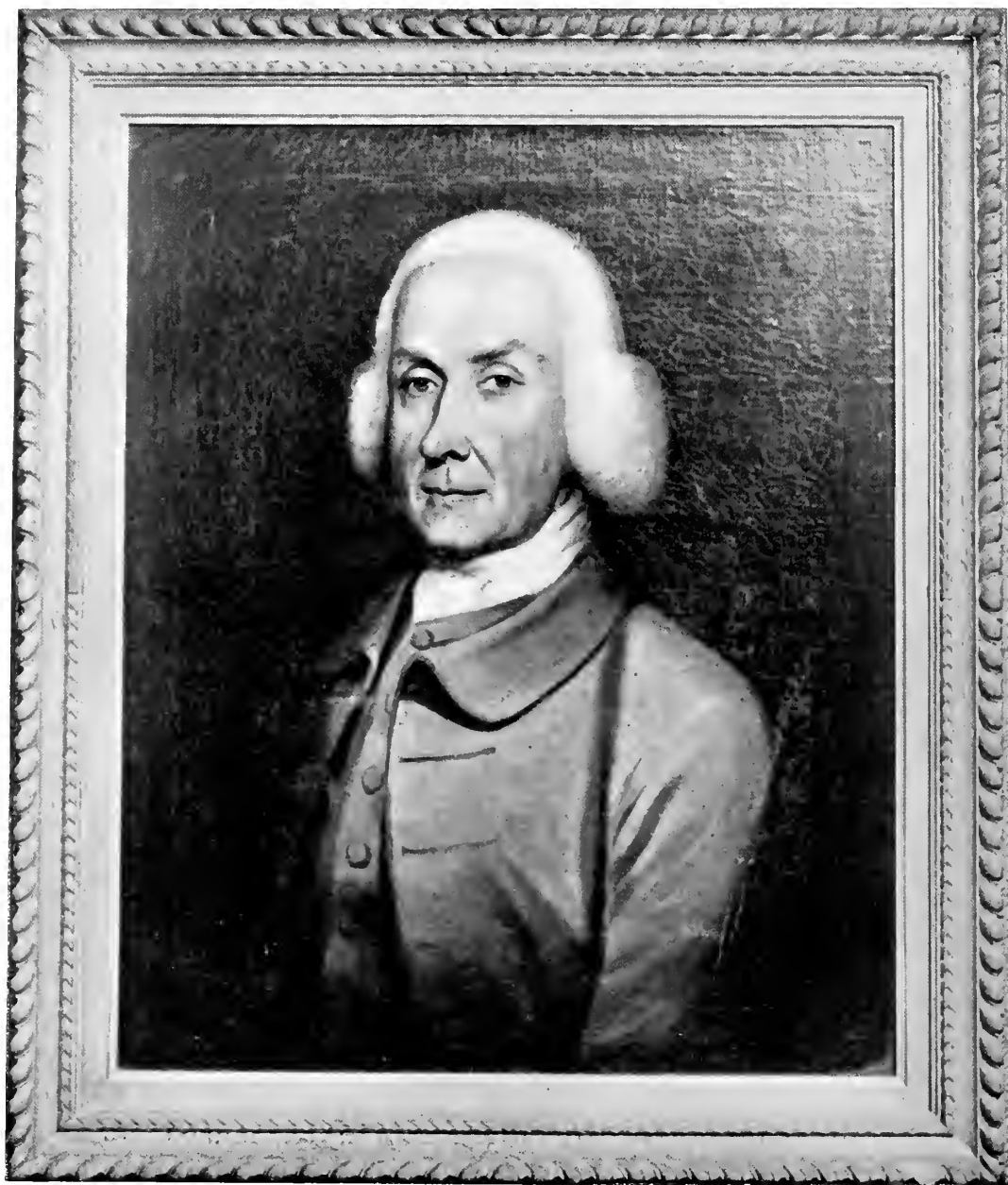

THOMAS BOULSOVER, born 1704; died 1788.

From an Oil Painting in the possession of Mr. J. B. Mitchell-Withers, of Sheffield.

PART II.

WHAT IS KNOWN OF THE EARLIEST MANUFACTURERS OF SHEFFIELD PLATE.

THOMAS BOULSOVER.

Boulsover was born in the year 1704, and died at Whiteley Wood Hall, near Sheffield, in September, 1788 (being interred at St. Paul's Church, Sheffield, on September 12th). He was generous and unsuspecting to an extent which perhaps enabled others to make from his invention the fortune that was rightly his due. Through the courtesy of the great-great-great-grandson of this eminent man, Mr. J. B. Mitchell-Withers, of Beauchief, near Sheffield, the author is able to reproduce a portrait of his ancestor. An Old Sheffield plated salver presented by Boulsover to his daughter, Mr. Mitchell-Withers' great-great-grandmother, on her marriage with Joseph Mitchell in the year 1760, is illustrated below.

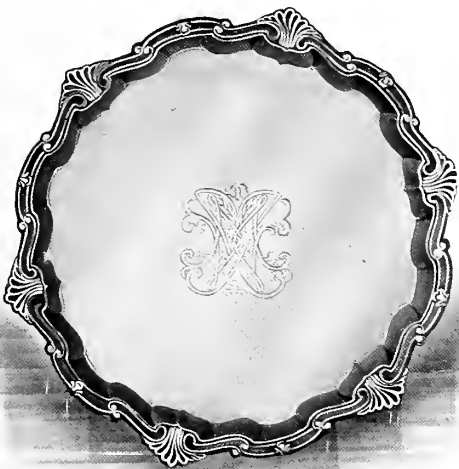

14 in. Salver, presented by Boulsover to his daughter
in the year 1760.

Reverse of Salver, showing inscription.

The property of Mr. J. B. Mitchell-Withers.

JOSEPH HANCOCK.

The widespread occurrence of the name Hancock in Sheffield, and the fact that there were several contemporary Joseph Hancocks during the eighteenth century, make identification of their several personalities difficult. The result of careful research compels the acknowledgment that while our knowledge of the silver-plating Joseph Hancock is disappointingly meagre, the scanty and usually accepted accounts of him are also not free from elements of great doubt. Eyam claims him as the descendant of a family whose fate forms one of the most harrowing tragedies of the Plague in that village in 1666. The tradition may contain some elements of truth, although the Eyam Church Registers have been searched in vain for proof, nor can any confirmation be found in the Cutlers' Company's records of the statement that his ancestor was apprenticed to a person in Alsop-fields, Sheffield, unless he were an Isaac Hancock who is mentioned as depositing tobacco boxes with the Cutlers' Company for sale, in 1680. In that year a mark was assigned to this Isaac, which proves that he had gone through the qualifying apprenticeship and had taken out his Freedom, but as the records of his indenture and admission have not been found, there is no clue to his parentage. Nor does the assertion, so often repeated, that Joseph Hancock was himself apprenticed to Thomas Boulsover bear the test of examination. He was born in, or about, 1711, so that under normal conditions he would be bound in 1725, and be entitled to his Freedom on coming of age in 1732. The apprenticeship lists of that period contain two entries: (1) Joseph, son of Benjamin Hancock, apprenticed in 1728 for $3\frac{1}{4}$ years to Thomas Mitchell, cutler; (2) Joseph, son of Simon Hancock, of Barlow, nailer, deceased, apprenticed in 1732, for 1 year 8 months, to John Green, cutler, admitted to Freedom 1734. Of these the first best accords with the conditions of our inquiry. The presumption is that the apprentice having, as was usual at the time, been instructed by his father, was sent to finish his training under another master. Although no admission to Freedom is recorded, his pupilage would end in 1732, which is the year in which Joseph Hancock, the future silver-plater, attained his majority. And in view of the connection of Boulsover with the Mitchell family, the apprenticeship to Thomas Mitchell is not without significance, as suggesting how some confusion, substituting Boulsover's name for his as Hancock's master, might easily, in course of time, arise. Especially would this be likely, if, as is probable, Boulsover and his relative, Mitchell, worked on the same premises. For we find that in 1774 the Assay Office took up its abode in a "dwelling

house lately occupied by Mr. Thomas Boulsover, situate up a court in Norfolk Street," the property of Mr. Joseph Mitchell.* It may be noted, too, that Boulsover himself did not take out his Freedom until 1726, if this entry refers to him: "Thomas, son of Samuel Boulsover, apprenticed to Joseph Fletcher, cutler, Freedom 1726." It has to be admitted however that though this Samuel was a native of, and apprenticed in, Ecclesfield parish, no trace of Thomas Boulsover's birth has been found in the register there.

These speculations would be idle if a statement sometimes made that Joseph Hancock was by trade a brazier could be established, because in that case he was ineligible for membership in the Cutlers' Company. The brazier assertion may be at once dismissed, as there is no shadow of doubt that the Joseph Hancock with whom we are dealing was Joseph Hancock the Master Cutler 1763-4. This is established on indisputable testimony. In a description of Sheffield, published in the "Gentleman's Magazine" in 1764, the Rev. Edward Goodwin, an accurate and well-informed authority on everything connected with the town, speaks of this Joseph Hancock as the "present Master Cutler." The newspaper notices of his death in 1791 repeat the assertion; and Mr. Hunter,† who wrote while memory of Hancock was still fresh, and who probably knew his widow, who did not die until 1802, had no hesitation in speaking of Hancock as a member of the Corporation of Cutlers, as "the Father of silver-plated manufacture," and as the Master Cutler of 1763. Elected Assistant in 1757, this Master Cutler passed through the successive offices which led up to the chair, and then served, as the custom was, for another twelve months as Searcher, passing off the Court in August, 1765. In the same year in which he was Master Cutler, Joseph Hancock was elected a Town Trustee. He was one of the thirty original Guardians of the Assay Office appointed under the Act of 1773, and he continued to hold both offices until he died on the 25th November, 1791, aged 80.

The year 1761 has, in some records, been given as the date when Joseph Hancock commenced the manufacture of plated articles. It will be seen later that Charles Dixon, previously quoted, places it in 1751.

In his historical introduction to the Directory of 1797, the Rev. Edward Goodwin gives "about 1758" as the time. He says (p.21):—

"Buttons of brass or copper plated with silver were made by Mr. T. Boulsover about 50 years ago. But about 1758 a manufactory of this composition was begun by Mr. Joseph Hancock, an ingenious mechanic, upon a more extensive scale, comprehending a great variety

* Watson's "Sheffield Assay Office."

† Gatty's "Hunter's Hallamshire," 1869 edition, page 168.

of articles, such as tea-urns, coffee-pots, saucepans, tankards, cups, candlesticks, &c., &c. Since that time this branch has been pursued by various companies to great advantage, which has greatly contributed to the wealth and population of the town."

And from the same pen we have, in the communication to the "Gentleman's Magazine" above mentioned (1764), a further indication of Hancock's varied activities. After speaking of the silver plated manufactures, Goodwin says: "There is likewise reason to believe that here were first made snuff boxes, candlesticks, &c., of a sort of coal called kennel, or cannel coal (formerly got near this place), by Mr. Joseph Hancock, who is the present Master Cutler." The memory of these cannel coal* articles has been lost, but an earlier reference to them is found in the account of a visit paid to Sheffield by the Countess of Oxford in 1745, when her ladyship "was so good as to present" her suite "with some coal ware." The importance of this for our present purpose is that it emphasises what is said hereafter, as to the ease with which Sheffield artizans would substitute the newly invented plate for the materials they had been accustomed to use in the manufacture of many articles.

In looking through early references to the plating industry one cannot but be struck with the extent to which, in the eyes of contemporaries and immediate successors, Hancock eclipsed the fame rightly belonging to Boulsover. It is evident that in local estimation the former rather than the latter was, to employ a title often applied to him, "the Father" of the manufacture. We have previously noted a persistent determination to regard Boulsover's discovery as accidental, and to belittle the use he made of it; and this tendency increased as Boulsover's efforts took other directions and as Hancock showed enlarged enterprise. A newspaper record of Hancock's death (1791) says: "This gentleman might have been justly called 'The founder of the plated business in Sheffield,' as he was the first person who commenced a manufactory of these goods." And when his widow died, in 1802, the statement was repeated in similar terms. In "Peak Scenery," published in 1818, Ebenezer Rhodes, who had been Master Cutler in 1808, and who must have been personally acquainted with both Boulsover and Hancock (he was 26 years of age when Boulsover died) improved upon this, ignoring Boulsover altogether. Speaking of the Hancocks of Eyam (part I., p. 42), he wrote:—

* Cannel (a corruption of candle) is a mineral, bituminous coal, capable of taking a high polish like jet, which it somewhat resembles. It is chiefly found in Scotland and Lancashire, but pockets of it are not unknown in the Yorkshire district. It is chiefly used in the manufacture of oils. Its inflammable nature would suggest some danger in using it for candlesticks. Wares made of this substance are now curiosities rather than articles of commerce, although it may be noted that a wine cooler, and some smaller ornaments, were shown at the Great Exhibition of 1851.

“About the year 1750 a Mr. Joseph Hancock, a descendant of this family, discovered, or rather, recovered, the art of covering ingots of copper with plated silver, which were afterwards flatted under rollers, and manufactured into a variety of articles in imitation of wrought silver plate. This business he introduced into the town of Sheffield, where it has since become one of its most important and lucrative concerns. Birmingham has attempted to rival this elegant manufacture, but, with the exception of the Soho establishment, its pretensions are humble.”

One's first impression on reading this is that by “recovered” Rhodes implied that the art of plating by fusion, whose discovery by Boulsover he ignores, had been in existence and lost. But from what follows it is clear that the writer did not realise the essential differences in the processes of manufacture. Silver plating was to him silver plating and nothing more, and he did not concern himself with methods of fabrication. For he goes on to explain:—

“I have not hesitated to use the term recovered as applicable to the art of which Mr. Joseph Hancock has been considered the founder, for I am well aware that the practice of covering one metal with another more precious is of great antiquity. That articles plated with silver, particularly candlesticks, were in use during the reign of Henry VII. can hardly admit of controversy. A specimen of the work of that period of time was lately taken out of Lady Idonea Percy's monument in Beverley Cathedral; a circumstance of itself sufficient to establish the correctness of the opinion here expressed. Some few years ago, when fewer restraints were imposed on commercial pursuits, nearly five thousand of the inhabitants of the town of Sheffield derived employment and support from a manufacture recently brought into existence by a branch of the unfortunate family of whose rapid and almost total extinction Riley gravestones are the melancholy record.”

The obscurity which surrounds Joseph Hancock's ancestry enshrouds also his descendants. A William Hancock, early entered as a Sheffield silversmith at the London Goldsmiths' Hall, gave evidence before a committee of the House of Commons in 1773, complaining of the treatment of his goods by the London Assayers.* And White's Sheffield Directory for 1833 (p. 44 note), making the erroneous assertion that “the first Britannia metal manufacturers were Messrs. Ebenezer Hancock and Richard Jessop,” adds, “The former was the son of the before-named Joseph Hancock, the celebrated silver plater.” But, except that there was, in 1793, a snuffer-maker named William Hancock, the William Hancock of 1773, and the later Ebenezer Hancock, have alike eluded further research.

Having given Dixon's views on the discovery of the process of plating by fusion and its subsequent adaptation by Boulsover, it is interesting to learn what he has to tell us with regard to Joseph Hancock and the uses to which he applied Boulsover's invention.

* “The Sheffield Assay Office,” by Arnold T. Watson, pp. 10, 11. In that year (1773) we find William Hancock in partnership with John Rowbotham.

“Mr. Joseph Hancock, in the year 1751, being a person possessed of a small capital, and a man of genius and an enterprising mind, was the first person who made any practical improvement in the use of the silver-plated metal. He it was that led the way from a button to the candelabra, the plateau, the épergne, the splendid cup, &c. Thus it is seen from small beginnings one of the most popular trades in the town and the kingdom had its origin, and the progressive improvements made in it are astonishing.

The first articles made by Mr. Hancock were saucepans plated inside.* Amongst the articles manufactured were plated spoons and vegetable forks, put together in two parts and filled with soft solder.† The makers then manufactured salt sellars, which had generally blue glass in them to hold the salt. Candlesticks were then made, and one, the Corinthian, was very neat, care being taken to preserve the Order in its construction. They used to have the nozzle of the candlestick, which holds the candle, stamped and put together in two parts, they at that time not knowing how to plate the metal on both sides, this they called the cow and calf; also any article or parts of an article they used to put together in the same manner for double plated metal.

It was some years after the discovery of plating that the art of plating on both sides or double-plated metal was found out. This opened a wide field for the display of genius. They then begun the manufacturing of dishes and covers, tureens, bread baskets, butter boats, tea pots, sugar basins, cream jugs, etc., etc., and when the art of drawing plated wire was brought to perfection‡ fresh ideas sprung up and then began the making of caster frames, liquor frames, toast racks, snuffers, branches, etc., etc.

As the trade increased in the plated line, it also extended in the silver trade and was the means of great improvements in it. A great inconvenience was experienced by the silver makers, for they were obliged to send the manufactured articles to London, York, Newcastle or Chester to be assayed, there being no assay office at that time in Sheffield. The conveyance of the goods there and back again was attended with considerable delay and expense. It was not until the year 1773 that the Act of Parliament was passed for the Sheffield Assay Office, and then it was under great restrictions. They were not allowed to use the same quantity of alloy for the Sheffield standard as they are in any other Assay Office in the kingdom, the Sheffield alloy being 3 oz. 5 dwt. of copper to 50 oz. of silver (fine), so that at this time if by mistake or otherwise any article will not pass the Sheffield Assay Office it may pass in any of the other offices. In the year 1775 there were 3,070 lbs. of manufactured goods assayed in Sheffield, which was a proof of the increase of the silver trade, and the plated trade rose more in proportion than it did.

As the trade further increased it gave encouragement both to the employer and the employed, and the study of patterns and fashion rapidly increased in the numerous manufactories that had then commenced, and ornamental die-sinking work was greatly encouraged.

The trade was greatly obligated to the Wedgwood and other china manufacturers for a many of their most beautiful patterns. The study of the ancient ornamental drawings was another source of patterns, and I have known a person when in London go on purpose to Westminster Abbey there to find out something that might take the attention of the customers when made up into tea urns, vases, ice pails, etc.

* See illustration, page 32.

† See illustrations, page 336.

‡ See pages 79, 80 and 81.

When Mr. Hancock had been in trade a little time, it was soon discovered what a wide field for speculation was opened for the employment of capital. Several firms began business and were chiefly formed of men of respectability, integrity and perseverance. Messrs. Winter & Parsons, Tudor & Leader, Ashforth, Ellis & Co., Matthew Fenton & Co., Mr. Roberts, Young, Mortons, etc., etc., were what we may call in the old school: but it was to these persons we owe the training of the trade from its infancy. There was a great competition amongst them which house could produce the best articles and the cheapest.

When the trade was first begun workmen were obtained from the silversmiths' shops in London as foremen or managers, and a great number of copper braziers were employed to raise and hammer the parts of some of the articles. All the parts of the candlesticks were made from the dies under the stamp hammer, and put together to form the pedestal or shaft, and were invariably hard soldered (or silver soldered), which was a considerable expense, besides the quantity of labour they took more time to execute the work, the articles being left in a soft or more malleable state than are now from being soft soldered makes them far better for the purchaser and they are more substantial. Another source that the masters had recourse to for workmen was if they knew of an ingenious man in the cutlery or any other trade they would if possible have engaged him into their employment, which was productive of some of the first-rate hands in the town, and at one time good workmen were considered very valuable, and there have been instances of men owing their masters £100 at one time. One instance I will relate.

Henry Sephton, who resided in Cross Burgess Street, and worked for Old Roberts (there being a young Roberts at the time—the present Mr. Samuel Roberts), kept an hunting horse, which he called “Fido.” He went to the warehouse and says to Mr. Roberts, “Well, sir, I have been looking over my account and I find I owe you £95; be so good as let me have the other £5 and to make it an odd £100. I will then begin of working in right good earnest, and I can soon pay off the amount.” Mr. Roberts lent him the money as an inducement to let him receive the benefit of his hand labour. The journeymen silver platers have in general been a very respectable body of men, and I have seldom heard of any misdemeanor being committed by any of the trade. Their earnings at one time were great, averaging from 30s. to 45s. weekly, and some excellent workmen a great deal more. At that period of time the masters were in the habit of keeping large stocks of goods on hand, on speculation, which was a great disadvantage to them, and from the caprice of fashion changing the goods were often sold at a less price. They thus lost a part of what should have been profit, but still it kept the men in employment.”

An instructive confirmation of Dixon's statement as to the demand for labour and the enlistment of braziers into the new industry is afforded by the following advertisement, which appears in Ward's “Sheffield Public Advertiser,” for June 26, 1764:—“Wanted, two or three good braziers to work in plated work. Anyone willing to serve in this branch by applying to the printer of this paper may meet with very good encouragement.” About 1772, the Cutlers' Company complained that “several members had quitted the trade of cutlers and become manufacturers of silver and plated goods, yet such Freemen continued to bind apprentices at the Cutlers' Hall, and the indenture expresses that such apprentices so bound shall be instructed in the



Sheffield Plate Saucepan, 14 in. long over all, holding $1\frac{3}{4}$ pints, of fused plate beaten out by hand—showing marks of the hammer—made before the days of rolling the metal out in sheets. The material has cracked slightly in the raising, and has been soldered up with silver. Plated inside only, the deposit is of great thickness. ^{JOSH HANCOCK} SHEFFIELD is marked on the handle, which is riveted to the body.

Date 1755. Author.



Sheffield Plate 1 quart Jug, an early attempt. The lip and handle supports are riveted on to the body—metal plated on one side only. The shape of the body has been attained by raising and hammering as described on pages 110 to 112.

Date 1755—1760.

Author.



Silver 1 quart London-made Jug, showing similarity of outline to the Sheffield-made one. The design of the Sheffield Plated Jug evidently adapted from the shape of contemporary Silver Jug.

Date 1755—1760.

Author.



Sheffield Plate, 10 in. shell pattern Candlestick. The collettes and neck, also capital, are roughly swaged. The shoulder mounts, foot and nozzle have been struck in cast steel dies, and afterwards chased by hand. Up the stem will be noticed a little chasing to take the eye off the soldered seam, **JH** marked on the capital. Probably by Joseph Hancock.
Date 1755—1760. Author.



Sheffield Plate, 11½ in. Gadroon Pattern Candlestick, made by the same method as the shell pattern, but of improved construction, no seams being visible. **T&L** marked on nozzle. By Tudor & Leader.
Date 1760—1765. Mr. R. E. Leader.

business, trade or occupation of a cutler ; notwithstanding which, the apprentices are altogether employed in the silver and plate trade, and are not at all employed in the cutlery business, and never properly learn that trade." The Company accordingly gave warning that such conditions disentitled apprentices thus untaught as cutlers to their Freedom, and admission might be refused when their indentures had run their course.*

A few of the earliest specimens of the industry in the form of articles for household requirements are here illustrated. Attention is called to the illustration of Saucepan on page 32 as being the earliest authentic article that can with certainty be attributed to Joseph Hancock.

* "Leader's History of the Cutlers' Company," vol. 1, p. 78.

THOMAS LAW.

Besides what has been written about Boulsover and Hancock the following particulars concerning other early makers of the Sheffield Plate trade are of interest. The majority of these were, like Boulsover and Hancock, originally cutlers. Thomas Law, already mentioned in connection with boxes (page 19), was born in 1717, entered as an apprentice in the Cutlers' Company's books in the year 1730, took out his Freedom in 1738, and became Master Cutler in 1753. He died in the year 1775. His successors in business registered a mark, the squat vase , in 1784 (September 8th), at the Sheffield Assay Office.

A few years after the death, in 1819, of John Law, son of the original Thomas Law, the long connection of the family with the industries of Sheffield closed, although the name was retained up to 1828 in the firm of Law, Atkin & Oxley, "successors to the late John Law & Sons." Through various changes of partnerships, and trade descriptions, the original firm is to-day—somewhat indirectly, represented by Atkin Bros., of Truro Works, Sheffield.

HENRY TUDOR AND THOMAS LEADER.

The earliest "factory" that can be traced in connection with the industry was that established by Tudor and Leader. Thomas Leader, a member of an old family settled in north-west Essex, having served his apprenticeship with a London silversmith, came to Sheffield and commenced business in partnership with Henry Tudor, descended from a family of tanners at Welshpool, Montgomeryshire. The initial capital was chiefly supplied by a certain Dr. Sherburn, who had realised the importance of securing the co-operation of a skilled London silversmith in the development of the industry. The success of Dr. Sherburn's wise policy soon became manifest. Exceptional as being silversmiths pure and simple amidst competitors whose ingenuity was shown in adapting to other metals knowledge acquired in cutlers' workshops, Tudor & Leader took first rank as the largest and most notable makers of Old Sheffield Plate. It is not known what was Tudor's training, but from his prominence in the firm and in the trade, it is clear that he possessed special qualifications justifying Dr. Sherburn's choice. He came to Sheffield while very young, for he married a sister, or perhaps niece, of Boulsover's wife when only 20 years of age, and by the time he was 23 the business was already well established.

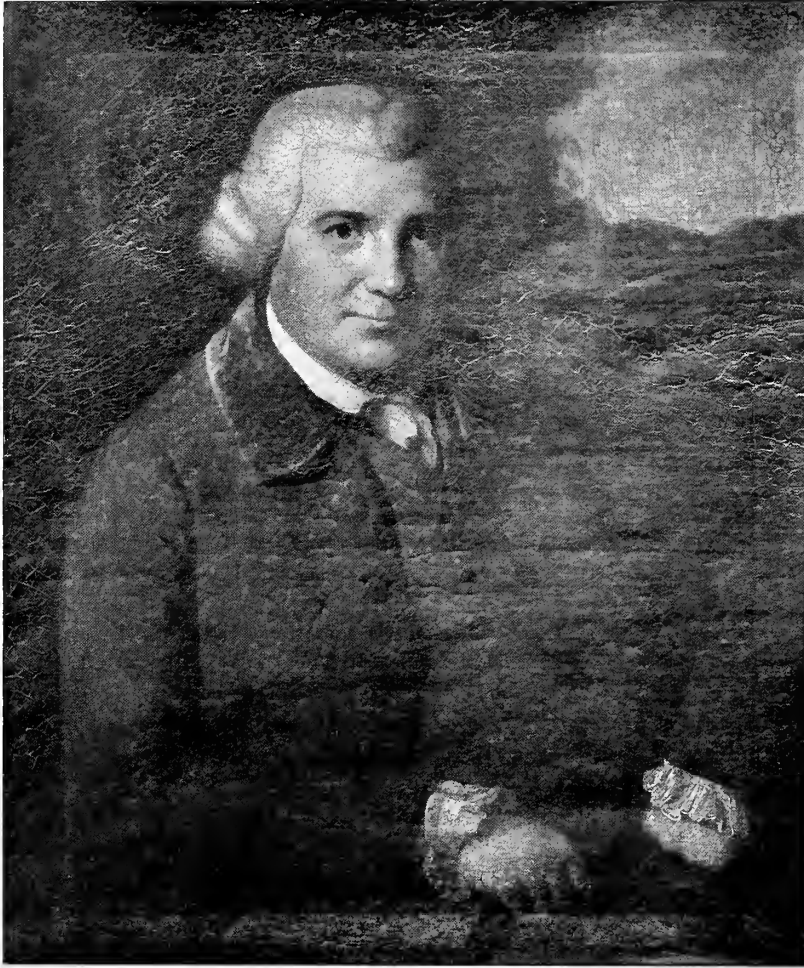



HENRY TUDOR, born 1738; died 1803.



From an Oil Painting, by F. Gainsford, in the possession of The Revd. J. Matthews, Broxbourne.

Henry Tudor was one of the seven Sheffield silversmiths who prior to the establishment of our Assay Office registered his punch and sent his silver goods to be assayed at the London Goldsmiths' Hall. He was afterwards a Sheffield Assay Office guardian.

In 1761 the firm had further assistance from Daniel Leader (a younger brother of Thomas, also a native of Essex), and the fact that he was apprenticed as a boxmaker shows the value still attached to that branch of the trade. Many of the designs characteristic of the products of the firm were, according to a tradition among old silversmiths, attributable to the artistic skill of Harry Hirst, Tudor's nephew. Excellent specimens of plate by Tudor & Leader, made about the years 1760-1765, are still to be met with. On the nozzles of candlesticks are occasionally to be found the initials *HT&L* and

there are other goods bearing the mark  In 1783 Samuel Nicholson was taken into partnership, and the name of the firm changed to Tudor, Leader & Nicholson. In 1784 they registered a mark for plate .





Thomas Leader in due time made a fortune, and about the year 1797 he retired to live at Broxted, Essex, leaving his brother Daniel, and his son Thomas Leader, Junior, in the business.

It would seem that, on the retirement of the elder Thomas Leader, the firm split up, and we find the two Leaders, Thomas, Junr., and Daniel, registering a punch at the Assay Office  whilst Henry Tudor with Samuel Nicholson as his partner registered the mark  in 1797. Tudor died in the year 1803, when this firm seems to have come to an end. Thomas and Daniel Leader carried on their business till the year 1816, when, being sharers of the fate that had overtaken, or was during the next thirty years to overtake, almost all the Old Sheffield Plate manufactories, the factory buildings, dies, and stock-in-trade were entirely dispersed. The workshops were on both sides of Tudor Street, then called Sycamore Hill, or Sycamore Street, and on a part of them a silver and plated business is still carried on by John Round & Sons Limited. The partners lived in houses close at hand. The tradition that a room in Tudor & Leader's premises was the one in which Boulsover was engaged when he hit upon the idea of making plate by the process of fusion has no foundation in fact, for the works were not then built.

THOMAS BRADBURY.

The statement is doubtless correct that the family of Bradbury is the only one remaining now actively connected with the plated industry who were associated with it almost from its inception. Joseph Bradbury was an apprentice in June, 1750, being admitted as a freeman of the Cutlers' Company ten years later. Thomas Bradbury, son of Joseph, formerly of Abney, Derbyshire, born in 1763, was apparently apprenticed to the firm of Matthew Fenton & Co. about the year 1777, being the grandson of Joseph and great grandson of Nicholas Bradbury, who in the reign of Charles II. owned property which still bears the family name at "Rushop Edge," Peak Forest, Derbyshire. This family was a branch of the Bradburys of Ollerset Hall, near Chapel-en-le-Frith, of whom one member can be traced engaged in commercial pursuits as far back as the 16th century—Sir Thomas Bradbury—being Lord Mayor of London in the year of the accession of Henry VIII. (dying during his year of office). On the 12th October, 1785, being then 22 years of age, while still in the employment of Matthew Fenton, the aforementioned Thomas Bradbury

entered into an agreement to take and teach an apprentice (John Fenton). Matthew Fenton died in 1795, whereupon his business was sold to Thomas Watson, of the Shirecliffe Hall family, whom Thomas Bradbury joined as partner (17 May, 1795), the style of the firm being soon changed from T. Watson & Co. to Watson & Bradbury.* Thomas Bradbury died in 1838. Thomas Bradbury the younger, born in 1786, and who died in 1855, was apprenticed to his father in 1800, and was, in 1807, gazetted as an ensign in the Sheffield Regiment of Volunteer Infantry. Joseph Bradbury, his son, born in 1825, does not appear to have signed apprenticeship indentures in the old legal fashion. He died in 1877.

Thus the firm of Thomas Bradbury & Sons, Arundel Street, is, as already indicated, the lineal descendant of Matthew Fenton & Co. The factory was located in the year 1773 in Mulberry Street. In 1795 it is spoken of as in Methodist Meeting Yard there. Thence, before the year 1832, it was removed to the building at the corner of Arundel Street and Surrey Street, where it remains to this day. The Watson interest, Thomas Watson having been replaced by his nephew William Watson in 1825, ceased about the time of the removal. Although registered as silversmiths in Sheffield 22 years earlier, this firm does not appear to have entered a mark for plated goods until the year 1795, viz., a ship  apparently but little used by them. The fact of this firm, of so old a standing, not registering a mark for plated goods until 11 years after the establishment of the Act may perhaps be accounted for by the reason that they were at first more largely interested in the making of silver goods than plated ones. Their earliest registered Sheffield silver marks   are still frequently to be met with on the Adam pattern candlesticks, silver pierced cake baskets, salt cellars, mustard pots, soy frame bottle mounts, etc., etc., made about the year 1775†; whilst their London mark  is to be found to-day on London Hall-marked silver goods made ten years earlier than this. Through being more commonly known at this time as "Fenton Creswick & Co.," the firm has often been confused with T. & J. Creswick, a subsequent firm of platers who registered the mark, the cross arrows, in 1811. No connection between these firms ever existed. Sometime between 1785-90 a partner was taken in named Oakes, the firm for a time being then described as "Fenton, Creswick, Oakes & Co."‡

* A James Fenton was with them at first, but he soon left to join in partnership with William Tucker, who had been in the firm's employment.

† A beautiful specimen of this firm's work in solid silver is to be seen at St. Paul's Church, Sheffield, bearing the local Hall mark of the year 1777. It consists of a large plain Communion Flagon, weighing 85 ozs., "The gift of the Revd. Robert Waterhouse, M.A., 1778."

‡ See Gales & Martin's Directory for 1787.

Matthew, son of Matthew Fenton, was apprenticed to Thomas Law in 1769. His sister, or cousin, Mary, had married the brother of Robert Gainsford, silversmith, of the firm of Gainsford & Nicholson, the picture of whose factory and its quaint old trade description is given on page 46. The name Fenton occurs later in Gainsford, Fenton & Nicholson (1825 to 1833).

Matthew Fenton & Co. were the second on the Sheffield books to register as "silversmiths," September 13th, 1773,* whilst we find that Daniel Bradbury was in that year the first appointed Assay Master. Seven Sheffield manufacturers registered as silversmiths at the Goldsmiths' Hall, London, prior to the establishment of the Sheffield Assay Office in 1773, viz.:—Matthew Fenton, William Hancock, John Hirst, John Rowbotham, Henry Tudor, Thomas Tyas, Junr., and John Winter.

SAMUEL ROBERTS.

In the latter part of the eighteenth century two, if not more, families of the name of Roberts were engaged in the manufacture of Old Sheffield Plate. Representatives of the one, descended from a sixteenth century Parish Church Assistant Minister, were associated with their relative, John Winter, in the firm of Winter, Parsons & Co., Market Place. Of the other with which we are here concerned, springing from Ecclesfield, were Jacob and Samuel Roberts, brothers. Brought up, like most of the early platers, as cutlers (Samuel having been apprenticed to Thomas Law), they, after being at Pond Hill, built works in Union Street. Samuel, as was the custom of the time, lived in a house adjoining the shop. They made table knives, and later on expanded into merchants, concurrently helping to found the silver plating firm of Roberts, Eyre, Beldon & Co., which claimed to have a priority in the London market, and had also Continental connections, conspicuously in Spain, to which country a son of Jacob Roberts made periodical business visits. Certain dissensions which had arisen among the partners in Roberts, Eyre, Beldon & Co. seem to have resulted in new combinations, for we find such firms (1785) as Beldon & Hoyland; Younge, Greaves & Hoyland, and so forth. Joseph Beldon, who died in 1796, was for some time in Pater-noster Row as the London representative of Roberts, Eyre, Beldon & Co. The names we have been mentioning show an inter-mixture of family relationships characteristic of the trading alliances of the period, for the

* The names in the Register are Matthew Fenton, Richard Creswick and William Watson—the last probably the brother, or possibly father of the Thomas Watson of 1795; but only a moneyed, not a working partner.



SAMUEL ROBERTS, born 1763 ; died 1848.

From an Oil Painting in the possession of Mr. Samuel Roberts, M.P., of Sheffield.

Roberts family was connected with the Beldons and Mortons, probably also with the Hoylands; while the brothers-in-law of Jacob and Samuel Roberts, John and Dennis Sykes, have handed down to us some of the best specimens of silver-handled cutlery.

It is believed that, Jacob Roberts having died in 1781, and his brother Samuel in 1799, the Union Street business was continued by Jacob Roberts, Junior, until his death in 1820.

The following extracts from a letter written by Samuel Roberts to a local newspaper in 1843 are of considerable interest concerning the Old Sheffield Plate trade's early activities and difficulties. :—

“It is this year, I believe, just a hundred since the first attempt was made so to plate, by a manufacturer of knives, of the name of Thomas Boulsover, who applied it to the making of the hafts of knives. I believe that he was joined by Mr. Wilson (who afterwards began the snuff trade at Sharrow Mill), and they, together, carried on the business for some time at Highfield, but they did not continue it long—though they attempted the making of various other articles of the same material. In the meantime, however, Mr. Joseph Hancock had taken up the business on a more extended scale. He succeeded in making many articles in what is called the braziers line, such as tankards, cups, coffee pots, &c. &c. to a considerable extent, and eventually established a mill worked by water for rolling the metal when plated, which—after himself giving up the manufacturing part—he employed in rolling the metal for such other manufacturers as had taken it up. The metal was at first rolled by hand, till Messrs. Tudor and Leader, and afterwards Mr. Winter, applied horse power. I can remember the little active old gentleman attending the candle-light suppers, as they were called—which were in those days commonly given annually by each house to their workmen. In this, as in almost all new trades, the originators failed of success. They, however, opened, smoothed, and paved the way for others.

The making of silver and plated handles for knives and forks soon became extensive. Mr. Law (grandfather to the late sculptor), on Baker's-hill, stood the first. With him my father and Mr. John Winter served their apprenticeship. Mr. Winter afterwards began to make both plated and silver candlesticks (but them only). Mr. Winter's business prospered. He would not suffer any soft solder to be used, but only silver solder. Hence his workmen used, in diversion, to call others soft-gob smiths. Candlesticks were then almost altogether columns of one of the five orders. Perhaps none more chaste have since been made.

About 1765, Mr. Winter and my father joined Mr. Morton, and four others, in making all kinds of plated goods excepting candlesticks—the making of which Mr. W. was to retain to himself. The plated trade had then become considerable. There were about six houses engaged in it, and almost all kinds of goods had then become made of plated metal which had been made of silver. As the trade was completely new in Sheffield—where no similar goods, of any metal, had been made, workmen at all qualified to manufacture them had to be sought for from London, York, Newcastle, Birmingham, &c. Those who chose to come were, of course, generally indifferent characters—many of them very bad ones; therefore during the first forty years the journeymen platers were, as a body, the most unsteady, depraved, and idle of all other workmen. They were not only depraved themselves, but the source of depravity in others. They were, in fact, in many respects a pest to the town. The masters could neither do without them, nor obtain better. They were, therefore, forced to give them high wages, and to wink at all their irregularities.

From this cause the masters were continually enticing the workmen from each other's houses, giving them a kind of security. There were in consequence continual disputes between masters and workmen, and between masters and masters about them.



Such, generally speaking, were the workmen of the plated manufacturers of those days when, in 1784, with a steady and highly respectable young man who had, as apprentice and journeyman in my father's manufactory, saved four or five hundred pounds, I began business. He was the first that ever put silver edges on plated goods.

After a firm stand was once made to the great and growing depravity of the workmen in the plated line, many circumstances combined to raise them to an elevation above workmen in, perhaps, any other line. The wages which they could earn were (in proportion to others) high. Young children could not be employed. A desire to put boys to it was thereby much increased. Fourteen was the general age of those taken as apprentices, and twenty pounds, or two years' board, were generally expected with them. This caused the boys taken to be respectably educated ones. This has been one great advantage. Another has been that fluctuations in the prices of making plated goods has been almost unknown. Whether trade was good or bad, the prices paid for making remain the same. So it was with the price of the goods sold. However silver or copper, tin, or other articles might rise or fall, the gross price of plated goods remained the same. Disputes between masters and men have, therefore, of late been very few.

I shall mention another advantage as attaching to the Sheffield workmen in the plated line, for to them, I fear, the superiority is confined. A general conviction has prevailed from the first among the manufacturers of plated goods at Sheffield, that it was their interest to maintain the quality of their goods. There have been exceptions, but only a few instances of no importance. That, however, has not been the case at Birmingham, where articles of a very inferior quality are commonly manufactured for the foreign market. This has been a means of purifying our plated working class at Sheffield. It has induced our bad workmen and depraved characters to leave us and to go to seek employment there. This, while it has raised the status of the working class, has raised also the character of our goods, and has served to keep up their prices. The number of workmen in the plated line are comparatively few. Great skill is required, and, therefore, the trade cannot be much overstocked, as the masters now take but few apprentices, while depraved characters from other trades cannot obtain admission."

What Samuel Roberts says in the foregoing extract affords an excellent illustration of the perplexing complications encountered by any one seeking to unravel the intricacies of the old plating partnerships. A glance at the lists given on subsequent pages shows the difficulty of resolving into their component parts frequently changing combinations, which included not only members of the same family or non-related bearers of the same surname, but also individuals who in some cases were principals in two or three distinct concerns.

The earliest record we have of those who joined Morton and others is much later than "about 1765," for it is found in the Assay Office Register of 1773. In that year a mark for silver was entered  by Richard Morton, John Winter, Samuel Roberts, Thomas Warris, John Elam, Thomas Settle, John Eyre, and Nathaniel Smith. Winter's presence in this firm explains the fact that when, in 1779, presenting to the Cutlers' Company "an elegant" gilt silver cup bearing the stamp "R. Morton & Co., fecerunt," he described it as "of his own manufacture." Its date letter is 1776.

Besides being a member of this firm and engaged in the Parsons candlestick factory, Winter had a third string to his bow and Roberts a second, for on the same day as the entry of the previous mark, there was also registered another  by Samuel Roberts, John Elam, Thomas Settle, John Eyre, and Nathaniel Smith. The address given in both cases was Brinsworth Orchard, or as it is elsewhere described, "near Fargate." Thus here were two contiguous firms, the one trading as Richard Morton & Co. and the other as Roberts, Elam, Winter & Co., and while Morton was the principal partner of the one, Roberts dominated the other. In 1780, Settle (with Warris) and Morton, at the old address registered separate marks  and .

In 1793 there was a further re-arrangement, including new men, when Joseph Wilson, who has been mentioned (page 40), took the lead, the mark registered being . But death soon ended this and the survivors were scattered. In 1781 Roberts, with John Eyre, had gone off to Union Street to found the firm of Roberts, Eyre, Beldon & Co. In 1787 both of the Fargate firms—Richard Morton & Co. and Roberts, Elam, Winter & Co.—have disappeared, Roberts, Eyre, Beldon & Co. succeeding the latter.

As to the Market Place candlestick-making firm, this in 1783 had been changed from "Winter, Parsons & Hall" to "John Parsons & Co.," John Winter having apparently retired, as in 1787 he is described as "gentleman," living in "Church Yard." The "Co." associated with John Parsons, as we know from certain legal documents connected with the will of John Winter, who died 1792, were William Ashforth (Ashforth being a name also met with in Ashforth, Ellis & Co.), John Roberts, Samuel Mosley, and John Green. John Roberts (of a family entirely distinct from Samuel Roberts) and Ashforth were relatives of John Winter. Ashforth about that time went to London, being described as "of the City of London, silversmith and plaiter." In 1793 Parsons (who did not die until 1814) had retired from the firm, which had become "Green, Roberts and Mosley," otherwise (1799) "John Green & Co." The works were on the south side of Market Place, on part of what had been the Rose and Crown Inn, and they had a rolling mill in the disused Methodist Chapel in Mulberry Street. They were still in the Market Place in 1808. That is the last we hear of them. The exact date of their discontinuance has not been ascertained, but it was before 1814.

The influence exercised in the Sheffield silver trade by Samuel Roberts the second (whose portrait appears on page 39) was profound. Having served an apprenticeship with Roberts, Eyre, Beldon & Co., his father decided to start

him in a new concern, and built works for him at No. 9, Eyre Street. This factory was completed in May, 1784, when business was begun. Thus established, S. Roberts, Junr., by his early training, his commercial aptitude and his cultured taste, eventually eclipsed his less enterprising competitors. Of all the manufacturers of the middle period he stands out as the ablest in Sheffield. His inventions (together with those of his partner, George Cadman) included the introduction of silver edges, stamped silver-filled feet, handles and mounts, also of bright engraving on mounts and borders. He was the first to bring to practical application the process invented by "Wilks" of rubbing in silver shields, etc.* Roberts himself was a clever artist, and had he been brought up in this profession would no doubt have made a name for himself. One has only to study the finely outlined illustrations in the firm's catalogues to appreciate the more than ordinary inspiration imparted by him to many original designs.

For fully 25 years, between 1785 and 1810, he apparently influenced most of the designs and patterns generally adopted, and his trade mark, the Bell,  is at this period found on only the very best specimens of Old Sheffield Plate, he and Matthew Boulton, of Birmingham, being equally pre-eminent at that time in excellence of workmanship. Roberts took out a patent in 1790 for plating on to white metal. He also took out a patent for telescopic candlesticks in 1798, and these we find to-day, after considerably over 100 years of general use, to be in almost as perfect working condition as when they were originally made. He had in 1798 a patent for making nozzles of candlesticks; in 1807 a patent for folding toast racks; in 1812, working levers on wash basins of metal (unconnected with his particular trade); in 1824 a patent for doing away with the silver edges to plated goods; and his last patent was as late as the year 1830, being for plating on to the then recently discovered german silver.

A contemporary silver plate manufacturer, who knew Roberts well, wrote as follows concerning the start he made in life as a manufacturer, in the year 1784, with George Cadman:—

"An indefatigable genius, with a coadjutor of experimental industry, who contemplated the idea of advancing the credit of Sheffield Plate, he always succeeded in being in advance of all his competitors, none of whom had genius that could compare with his. His competitors apparently awaited his productions before deciding on which lines their own goods were to take shape. The quality of his plated goods and the correctness of their outline were excelled by none and equalled by few, Matthew Boulton being a rival of his amongst the makers of note at this time."

* See page 93.

“The untiring energy which Roberts evinced in designing soon obtained for him great pre-eminence in the manufacture of plated goods, and he took the lead in fashions as well as quality, so much so that for the first 20 years (1784-1804) he had few rivals. The next 20 years, however, 1804-1824, left him somewhat in the rear of his competitors, and the last 20 years, his imaginative powers becoming somewhat obscured on account of his age, he resorted to purchasing designs from others, at a high rate, such as would, in previous years have come spontaneously to him.”

Unfortunately, his memoirs record little of interest in connection with his particular business. This is very much to be regretted, as he had a masterful insight into every subject that he fully studied, and no small details and incidents, however apparently trifling and insignificant to the less observant, seem ever to have escaped his attention.

Notwithstanding the claims of a large business, Samuel Roberts was able to devote much time to benevolent activities and public questions. His pen filled the columns of the newspapers with pronouncements on all manner of current topics, local or national, and he published several books. What posterity most prizes, and regrets as all too slight, is his autobiographic sketch.

The details of the firm which Mr. Roberts founded, kindly supplied to the author by Mr. Walter Sissons from authentic records, are as follows:—

In 1786, two years after starting, Roberts & Cadman had the advantage of capital furnished by the Rev. Benjamin Naylor, of Upper Chapel, as sleeping partner; and another addition to the firm was Mr. George Ingall, the style then becoming Roberts, Cadman & Co. Naylor, who subsequently withdrew to join Montgomery in the proprietorship of “Sheffield Iris,” left the town in 1805 to engage in a Manchester cotton business. Ingall died in 1822; Cadman in 1823. In 1826 Roberts took into partnership his nephew, Evan Smith, son of the Rev. George Smith, of Ecclesall, with Sidney Roberts (grandson of the first Jacob Roberts and of Richard Morton), and William Sissons, all trained in the works, the firm becoming Roberts, Smith & Co. On the retirement of Roberts in 1834, his son, Samuel Roberts (the third), became associated with them, but on the death of his father, in 1848, he abandoned commerce, the business being continued as Smith, Sissons & Co. In 1858 Smith (who had represented the firm in London) retired, whereafter Sissons was joined by his two sons, William and George—“W. & G. Sissons.” Mr. Sissons, Senior, died in 1878; his sons retired in 1885, leaving the business in the hands of his grandsons, Charles and Walter. Since 1903 Mr. Walter Sissons has been sole partner, though the style of the firm, no longer in Eyre Street but St. Mary’s Road, remains “W. & G. Sissons.”

THOMAS NICHOLSON.

Thomas Nicholson, whose portrait is given on next page from a miniature kindly lent by his grandson, Mr. Alfred Nicholson, is a personality whose influence has made a lasting impression on the Old Sheffield Plate trade. The son of Samuel Nicholson, who was presumably connected with Messrs. Tudor & Leader in the latter part of the 18th century, was born February 20th, 1779. As he lived until the year 1860, his interests were for practically speaking seventy-five years bound up in the intricacies of both the old and new processes of plating. For about the last twenty years of his life he was associated with Messrs. James Dixon & Sons, perhaps the most celebrated and successful of the all-round plate manufacturers we have to-day in Sheffield.

He records that at the early age of six he was allowed the run of the factory with which Samuel Roberts, Senr., was associated. Initiated into the use of the hammer, he never tired of noting progress and recording his observations. At this early age, too, he commenced drawing designs in his copy book, with one of which (a tea urn), Roberts was so pleased that he actually had it made up from his sketches in Sheffield Plate.

Nicholson goes on to state that about the period (shortly after 1800), when everyone was getting weary of the plain designs in both silver and plated wares, he it was who introduced shells and dolphins into the gadroon mounts, followed by other decorations. This innovation completely revolutionised the then stereotyped designs and grew in intricacy and proportion to an extraordinary extent. The new fashion came into vogue suddenly and so completely that the London silversmiths of the period were compelled to follow it in order to make a living. The difficulties they had to contend with owing to the difference in their methods of manufacture of this period must have been very great; for they had to model and cast the borders of their floreated productions, whilst the Sheffield makers relied on the use of their dies. This is evidenced by the many soup tureens, cake baskets, etc., etc., with London hall marks made about 1812 and onward, the mounts of which are not so beautifully undercut and sharp as the locally made ones. Nicholson seems to have kept his genius for design all through his life; and he it was, who later on, when again the public was ripe for some further change, introduced the arabesque designs, and long curving plain scrolls, with an occasional leaf or flower, reed and ribbon, etc. He records that the old plate trade went through fluctuating periods of alternate success and depression during his lifetime. In his opinion a magnificent opening was afforded after

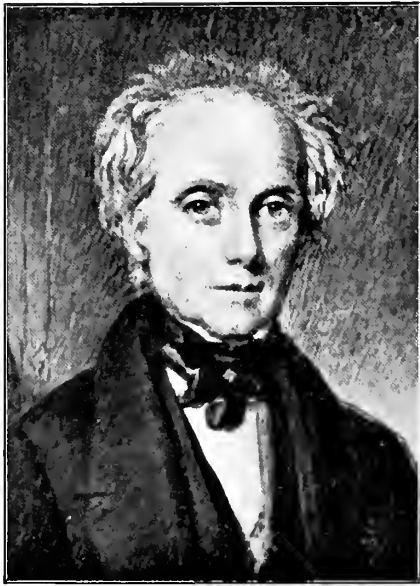

THOMAS NICHOLSON.
Born 1779; died 1860.

1810 for the sale of Old Sheffield plate on the Continent, but the Foreign Office turned a deaf ear to representations laid before it.

Curiously enough, 1816 and 1817 appear to have been the worst years he recollects for bad trade, reminding us forcibly of the slump in this country following the conclusion of peace after the Transvaal war. From 1812 to 1825 Nicholson's trade gradually declined to the extent of £1,500 per annum, in spite of increased energy and expenses throughout this period, in which latter year his firm's turnover (Gainsford & Nicholson) was £9,500; but by 1826 it had jumped up again to £12,000. In 1832 the state of the plating trade was again so bad that a Government enquiry was instituted into its cause.

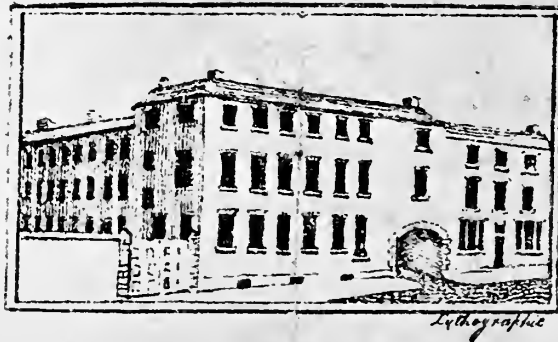

GAINSFORD & NICHOLSON'S *Manufactory* GYRE St SHEFFIELD
 Rich embossed Silver plate & all kinds of Plated Goods of the best quality. 1820

Nicholson's factory—dismantled in the year 1834.

His partnership with Gainsford terminated somewhere about 1833, and he took the keenest interest in the introduction of the new electro-plating process; whilst as early as 1830 he himself plated on German-silver as an experiment. This firm's mark was an elephant's head, registered in 1808



He was one of the eighty scientific men who witnessed Dr. Smee's great exposition of plating by the aid of the galvanic battery, about the year 1840, which it was then agreed must eventually supersede entirely the old process of plating by fusion (see page 140).

MATTHEW BOULTON.

Matthew Boulton, the younger, achieved greater public distinction than any other manufacturer of old plate, becoming a Fellow both of the Royal Society and Society of Arts. He was associated with the great James Watt, and, as will be seen from the list of productions detailed under the illustration of his factory, must have been a man of infinite resource. The number of Sheffield plate articles still in existence of his firm's make to-day is probably as great as that of any other manufacturer. He stood out alone in Birmingham as a successful rival of the best Sheffield plate makers.

To quote from "Samuel Smiles," he was born September 3rd, 1728, and educated in Birmingham—his father, Matthew, being of a good old and well-to-do Northamptonshire family living in Lichfield, whom it is presumed having at one time fallen into reduced circumstances, they sent their son Matthew to enter upon a business career in Birmingham.

Matthew Boulton, Junr., appears very early in his business life to have introduced at his father's factory several important improvements in the manufacture of buttons, watch chains, and other trinkets, and actually invented the inlaid steel buckles. The large factory shown on page 49 cost upwards of £20,000, and was capable of holding a thousand workmen. It was completed somewhere about the year 1764. It is easy to imagine how a man of the younger Boulton's talents would turn to the newly invented plating process, and we find him about this period introducing the manufacture of plated candlesticks, urns, etc., into his factory. It is recorded in notes written between 1840 and 1850 by T. Nicholson, that Matthew Boulton left Sheffield in 1764 (presumably having come here to acquire the details of his trade). He was always held in the greatest esteem we are told, and there was some talk before he left of his forming

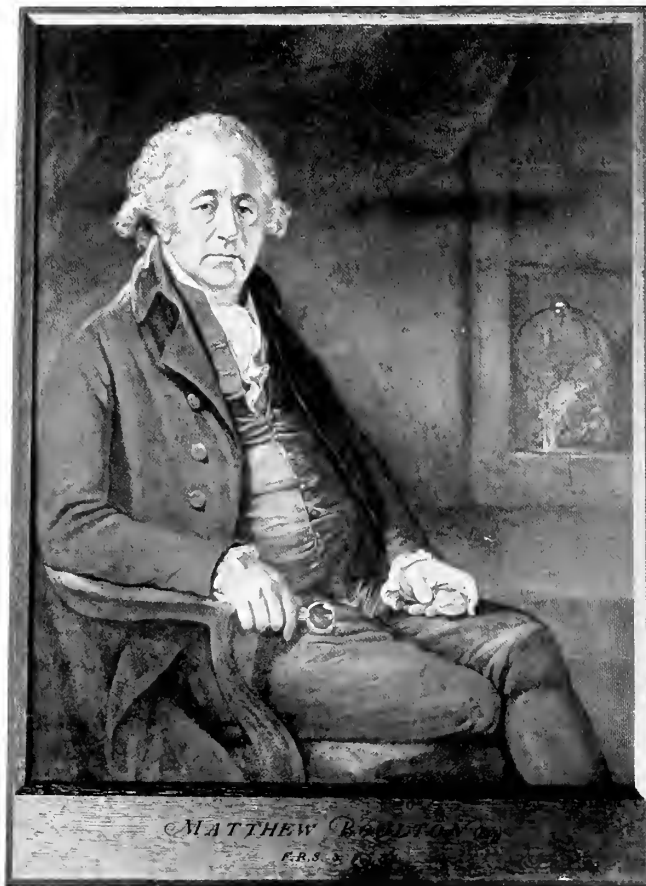

MATTHEW BOULTON, born 1728; died 1809.
From an Old Print in the possession of Mr. A. Westwood,
Birmingham.



M. Boulton commemorative medal.



Reverse of medal.



M. Boulton's Soho Factory, Birmingham, erected in 1764, from an old print in the possession of Mr. A. Westwood, Birmingham.

some kind of partnership with Richard Morton of this town. There is probably some discrepancy of dates here, as, if Boulton ever resided in Sheffield at all, the fact cannot be lost sight of that according to Smiles he was taken into partnership with his father in Birmingham soon after he came of age in 1749, whilst in 1759 his father being then dead, he assumed complete control of his business and immediately started to build the famous Soho factory. Boulton struck and presented, at his own expense, medals commemorative of the battle of Trafalgar, to the officers and men who took part in and survived the fight. His wife was a daughter of Luke Robinson, Esq., of Lichfield, the marriage taking place in the year 1749. The mark used by his firm previous to the year 1773 was ☉ B & F ☉* and in the year 1784 the mark, which he struck in duplicate, ☼ ☼ the sun, was registered at the Sheffield Assay Office.†

He thoroughly made up his mind to get rid of the "Brummagem" reproach, and he writes to his partner early in his career from London,

* Boulton & Fothergill. † The firm is described in the books as M. Boulton & Co.

saying, "The prejudice that Birmingham hath so justly established against itself makes every fault conspicuous in all articles that have the least pretensions to taste; how can I expect the public to countenance rubbish from Soho while they can procure sound and perfect work from any other quarter?"

With what success his efforts in this direction were attended is to this day most fully exemplified.

He frequently went to town for the express purpose of reading and making drawings of rare works in the British Museum, and when valuable objects of art were offered for sale he endeavoured to secure them. He did not confine his researches, however, to England alone, and it is recorded of him that he caused search to be made over the continent for the best specimens of handicraft as models for imitation.

One of his most ardent admirers was the Hon. Mrs. Montagu, who wrote to him, "I take greater pleasure in our victories over the French in the contention of arts than in arms; the achievements of Soho, instead of making widows and orphans, make marriages and christenings. Your noble industry, while elevating the public taste, provides new occupations for the poor, and enables them to bring up their families in comfort"—a very pretty compliment to Boulton's genius.

He appears to have had long interviews with the King and Queen, and to have been well known all over Europe, when distinguished foreigners came to England they usually visited Soho as one of the national sights. For many years the visitors at Soho House, Boulton's residence, were so numerous and arrived in such constant succession, that it more resembled an hotel than a private house. Amongst his many friends was to be numbered the great artist potter, Josiah Wedgwood, for whom, and other potters, Boulton did an extensive trade in mounting their wares with silver and Sheffield plate.

It seems almost incredible that such a hive of industry as Boulton's factory was should have so entirely disappeared; only his private residence now remains standing. The business was broken up in the year 1848, being at that time known as "The Soho Plate Co.," late "Matthew Boulton and Plate Co."

Boulton died on August 17th, 1809, aged 81, and was buried in Handsworth Church. He was followed to his grave by 600 of his work-people, and is described as a man of truly noble nature, generous, high-souled, and a lover of truth, honour, and uprightness.

The men who have been here specially mentioned as prominent were typical of many others, whose names will be found recorded, in various connections, in the pages of this book. To them as a class must be accorded

high praise for the excellent designs and workmanship characteristic of their wares. Unfortunately they were less skilled in the use of the pen than of the hammer, and in the absence of diaries the glimpses we have of their lives and labours are shadowy and difficult to focus.

It will therefore be a source of gratification if the publication of this volume be the means of throwing more light, not only on the early history of the old trade, but also of its pioneers.

Whether the saying that "hard work kills no one" be true or not, it is noticeable that of the seven industrial pioneers more particularly named, Thomas Boulsover lived 84 years, Joseph Hancock 80 years, Thomas Leader and Samuel Roberts each 85 years, Thomas Nicholson and Matthew Boulton each 81 years, and Thomas Bradbury 75 years; but possibly this longevity may be somewhat accounted for by the climatic conditions under which they laboured. Certainly no town in England is more bracing than Sheffield; whilst Birmingham also, being built on a tableland at as great an altitude as Sheffield itself, is in a remarkably healthy district for a manufacturing business.

In the year 1773 was formed in Sheffield the first local silversmiths' association, the members of which were—

Winter, Parsons & Co.	J. Hoyland & Co.
Hancock, Rowbotham & Co.	Richard Morton & Co.
Tudor & Leader.	Thomas Law & Co.
Fenton, Creswick & Co.	

The object of this Association was to form a combination of manufacturers who would agree to certain fixed selling prices for their goods, and restricting the discount to be taken off such prices to 20 per cent. for cash and 15 per cent. for credit.

In 1777 it was agreed to allow a discount of 10 per cent. to persons out of the trade who introduced customers and in settling the question of credit, the kingdom of Ireland was placed on the footing of a foreign country.

The meetings of this Association were held with tolerable regularity and were well attended. The appointed places of assembly were the various inns in the town, and members took the occasion to indulge in the convivialities of the good old-fashioned supper.

The punishment for non-attendance at these meetings was the cost of one supper, 8d., and a further fine of 2s. 6d., making 3s. 2d. in all. These fines were rigorously imposed and paid. The Association seems to have terminated in the year 1784.*

* The author is indebted to Mr. R. E. Leader for these notes.

PART III.

HISTORY OF THE TRADE.

ON WORKMANSHIP AND APPRENTICES.

It is not the object of this work to imbue the public with any exaggerated ideas of either the pecuniary or artistic value of Old Sheffield Plate, but one feels tempted to state that this ware varies far less in excellence of workmanship than any of the contemporary crafts. The majority of antique silver collected has, as a rule, been sought after more on account of its past history and antiquity than for its artistic merit and skill in production, whilst in the case of collections of Old Sheffield Plate the earliest specimens are by no means always those most valued or most eagerly sought after by experts. The various pieces have hitherto stood on their merits. Comparing the plater with the silversmith, there is very little doubt that at his zenith of success the former would arrive at a greater pitch of scientific workmanship than the latter. The best worker in fused plated ware would also be a silversmith, and would therefore have the double advantage of insight and experience in both branches of this industry. It may be admitted that design and style have often been at fault in many of the examples of old plate which have come under notice, but nearly always the workman executed his task well. Some of the older pieces—when the trade was in its experimental stages and difficulty in obtaining good workmen was being experienced—show exceptions to this rule, and leave something to be desired; but later on, owing to the niceties of manipulation, there could have been no half-way house on the road to perfection. In a general way an article had to be either good enough to finish outright or be destroyed altogether. To work up, say, a piece of plated copper into a teapot, required the exercise of great skill on the part of the workman so as to avoid cracking the metal or cutting through the silver coating, and thus making the article waste. Now, however, all kinds of rough work can be soldered up and afterwards covered over in the plating vat, and consequently it is not necessary for the workman to bestow the same care and pains when making up an article as it was in the time of Old Sheffield Plate. It is no exaggeration to say that since the introduction of electro-plating the

workmanship in the silver and plated trade has shown signs of all-round deterioration. To-day some makers even dip sterling silver articles in the plating bath to hide the discolouration set up during the process of soldering, technically known as "fire marks," but the practice is very unsatisfactory from the users' point of view.

As far as concerns the productions themselves in Sheffield Plate in the olden days, no deterioration in their manufacture can be traced. From the commencement of the industry until the very latest periods improvements and inventions were the order of the day throughout. The best examples are characterised by superb workmanship; and lasting durability was ensured by the infinite amount of rolling and subsequent hammering that the various pieces were subjected to during the making-up process. These operations had the result of closing the fibre of the metal in the same way as steel is toughened under the forging hammer or hydraulic press.

The formation of the various vessels, the joining of the parts, the hammering and mounting, the finish and decoration all represent a level of skill, and patient, conscientious effort on the part of the workmen such as are unfortunately not so conspicuous in the Sheffield ware of to-day.

A most important essential in the manufacture of Old Sheffield Plate was absolute cleanliness. Particles of dust, the slightest suspicion of greasy matter, and even a drop of perspiration from the hand coming in contact with the work would be fatal to the standard of finish demanded in the period under review. A craftsman possessing a dry hand had better chances of success than one whose hands were inclined to perspire.

Flat-hammering was one of the most important and difficult processes in the manufacture of plate, and a large proportion of the apprentices never succeeded in attaining proficiency. Successful hammerers were born rather than made. In these days of rapid production one learns with surprise of the extraordinary amount of time and care which was spent in flat-hammering a piece of plate in order to produce a perfect surface upon it.

The most apt apprentices to the plating trade invariably served seven years of long working days and few holidays, and before they were recognised as journeymen they were required to act several additional years as improvers. Illustrated on next page is a copy of the apprenticeship deed duly executed in the year 1800 between Thos. Bradbury, Junr., T. Bradbury, Senr., and Thomas Watson, these representing the firm of Watson & Bradbury, which gives some idea of the great care that was exercised for the welfare and in the bringing up of an apprentice to the trade over 100 years ago.



Form of apprenticeship deed in use in the 18th century by the old Sheffield platers.

INN PROPRIETORS AND OLD SHEFFIELD PLATE.

Soon after their introduction a great demand sprang up amongst the owners of taverns and inns for Old Sheffield Plated articles, more particularly as regards tankards and measures. So much so that certain firms made a special study of supplying material for their requirements. The measures appear to have to a great extent supplanted those previously made of pewter. Before the introduction of Sheffield Plate, all the best hotels would have in use a large proportion of solid silver, notably Wood's

hotel, Holborn, London ;* the Castle hotel, Bath ; Cross Keys hotel, Hull ; Fleur-de-lis, Canterbury ; White Horse, Ipswich ; Clinton Arms, Newark ; and many others can well be remembered to have had a considerable quantity of solid silver plate. And a great number of old inns have services of Old Sheffield Plate still remaining in daily use ; but unfortunately the hard strain



Large 7-bottle Cruet, with crystal bottles and solid silver tops. $11\frac{1}{2}$ in. long \times 10 in. high \times $8\frac{1}{2}$ in. wide, by Watson & Bradbury. Formerly in use on the dining table of an old coaching inn. Date 1810. Author.

of everyday hotel service during the last hundred years has made great havoc of even the toughest and best specimens of this ware. The largest quantity of Old Sheffield Plate in constant employment to-day is perhaps to be found at the London hotel, Exeter ; but its condition leaves very much to be desired.

* Notwithstanding the Act of 1696 which "prohibited any person keeping a tavern, alehouse, victualling house, or selling wine, beer or liquors by retail, to publicly use or expose to be used any wrought or manufactured plate whatsoever, or any utensil thereof, except spoons, under pain of forfeiture of the same," this hotel had at the time of its dissolution, now some 15 years or so ago, a very large quantity of silver plate, a goodly portion of which must have been on the premises during the period in which this Act was in force.

At Harker's hotel, York, there is still a fair amount of Old Sheffield Plate—and even antique silver—in very passable condition. At the Castle hotel, Bath, both solid silver and Sheffield plated articles were almost exclusively used until recently; whilst lesser quantities of the latter may still be found both at the “Saracen's Head” and “Spread Eagle” hotels, Lincoln; the Hop Market hotel, Worcester; King's Head, Cirencester; Royal hotel, Cheltenham; Castle hotel, Lynton; Castle hotel, Taunton; Castle hotel, Dartmouth; Lion hotel, Guildford; George hotel, Aylesbury; the Beaufort Arms hotel, Monmouth; the Fortescue and Royal hotel, Barnstaple; the Red Lion hotel, Salisbury;* the Swan hotel, Bedford; the White Hart hotel, Windsor, and many others. But at all these hostelries the articles are now very few in number compared with what they were twenty years ago.

HOW THE DEMAND FOR SHEFFIELD PLATE INCREASED AND DECREASED.

The efforts of the early silversmiths to discourage the plating of inferior with sterling metal by persuading the legislature and the public that goods produced in such a way were spurious, and the process immoral, utterly failed to prevent Old Sheffield Plate from being adopted by the highest classes of society. The rapidity of the growth of the industry was phenomenal, yet there could have been few possible buyers of such ware outside the ranks of the nobility and gentry. The presence of most elaborate crests and coats of arms on the majority of pieces now in existence affords ample evidence that noble families of the end of the eighteenth century felt no compunction in availing themselves of the new invention and buying Old Sheffield Plate to save their pockets. An enormous impulse was given to the industry forty years after its inauguration by the imposition of the duty on sterling silver in 1784. This naturally greatly increased the cost of the finished silver goods, and from that date it may be said to have made continuous and steady progress for upwards of five years, the quantity of goods turned out and the number of new firms commencing business both growing in volume. This duty was a serious item to face, and amounted eventually to about a 25 per cent. increased cost on the value of each manufactured article. A silver teapot hitherto costing £6 or £7, after the full duty had been charged, could not be obtained for much less than £9; a silver tray costing originally about £20 would be £25, etc., etc. This

* At this hotel there is still in use, amongst other articles, an Old Sheffield Plate eel pie dish, which has all the appearance of having been manufactured considerably over a century ago.

specific duty was met by the silversmiths with a lessening of the thickness of the gauges of silver used, in all cases where possible, and we find the craftsmen in Sheffield also imitating this new departure. Where these lightly-made pieces are found in a fine state of preservation in Sheffield plate, in many instances they cannot without a very close examination be distinguished from the examples of the same period in sterling silver ware.

Some few years later dies were brought into use for stamping the entire parts of the various articles (previous to this the bodies of Sheffield plated goods were most usually raised by hand labour). This made it possible to sell faithful reproductions of some of the silver ware then in vogue actually better made in many respects than sterling silver ware, and at the same time much cheaper on account of the great saving of cost consequent on the use of the said steel dies. Soon after the beginning of the 19th century the buyers of plate were augmented by the new class of merchants and manufacturers who were rapidly acquiring wealth, and who now constitute the middle class of the present day.

In 1789 the French revolution had such a serious effect on the Sheffield Plate industry that business was almost at a standstill. The trade with France, before this period and subsequently, was a considerable one, the foreign platers as a whole never equalling the degree of excellence in their workmanship that was attained by the Sheffield manufacturers. Many of the best articles of Sheffield Plate in the illustrated catalogues were described both in English and French, and goods were actually designed to meet the requirements of this market. This speaks highly for the pains taken by the manufacturers

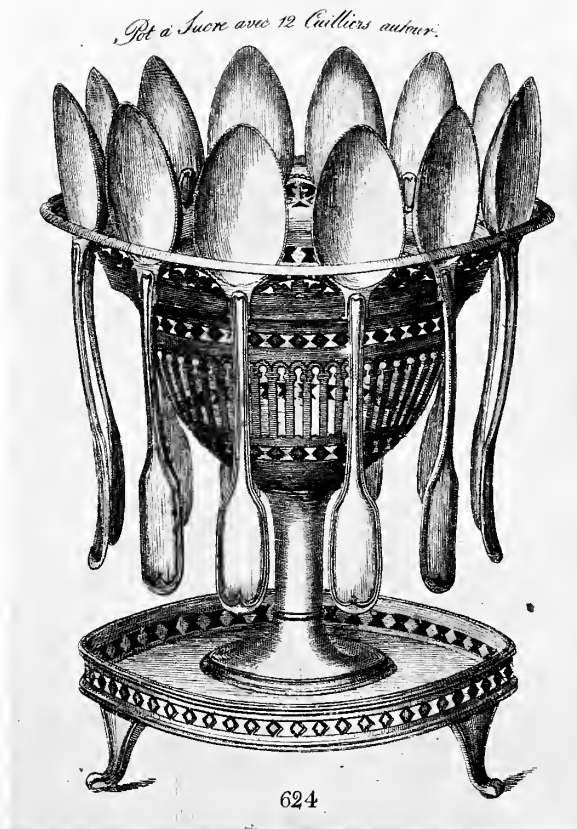

Illustration from an old Sheffield Plater's Catalogue, about the year 1784, intended for continental use.

both in making and distributing their goods. Roberts & Cadman, who had a large trade in France, also formed a considerable business connection with Spain.

From 1795 for the next twenty years, the unsettled state of affairs in Europe impeded considerably the export trade to the Continent. Fresh markets were, however, at that time springing up in British colonies, whilst from the year 1816 until the termination of the industry, though there were no wars to interfere with the uninterrupted progress of the trade, for some reasons this export business ceased. Whether or not it was that walls of tariffs were gradually being built up abroad cannot be said with any degree of certainty, but in the latest days of the industry there was an almost total cessation of export trade with European nations and the United States of America.*

HOW THE PLATE WAS DESTROYED ; WHY THE DIES WERE DISPERSED ; AND
WHAT BECAME OF THE MANUFACTURERS AND THEIR FACTORIES.

It is almost inconceivable that as recently as twenty-five years ago nothing was thought of pieces of "Old Sheffield," and the finest specimens could be purchased for as many shillings as they would now cost pounds.

It is also singular that comparatively recent as has been the introduction of electro-plate, so few of the earlier firms connected with the older industry remain still as plate workers. The factories of the majority of them have been sold and their plant and material dispersed. Quantities of the dies, that must have cost hundreds of thousands of pounds in the cutting alone (and would to-day be invaluable for use under the prevalent reversion from Victorian types of fashion) were melted down for the mere value of the metal, and those few firms surviving and having any number of the old Sheffield dies only too often find them incomplete.

From research it would appear that the period between 1852 and 1858 must be assigned as the approximate time of the dispersal and destruction of dies by the surviving Old Sheffield Plate makers. The Victorian styles of electro-plated articles had then become generally fashionable, whilst the method adopted of casting in German silver from models was gradually superseding the use of stampings from steel dies in the making-up process.

* Mr. James Dixon, of Messrs. J. Dixon & Sons, says "that up to the middle of the 19th century his firm's trade with America was so considerable that it was worth while for one of the senior partners to live there, and besides that they had also four agents in America. On the United States' first great protective Tariff coming into force in 1861 the firm's trade with that country vanished."

The factories in Sheffield were circumscribed as to their space, and much more room was required for fresh methods, appliances, and models in connection with the electro-plating process. The manufacturers appear to have thought that dies cut between the years 1810-1850 might some day once more come into fashion, but as for those of the earlier periods, the chances of re-introduction were remote. Therefore we find that the "Adam" and subsequent plainer patterns of dies were those more particularly condemned to destruction.

Old hands at the writer's factory can remember great quantities of dies being defaced and dispersed about the year 1855. At Messrs. Hawksworth Eyre's factory (the successors of the firm Blagden, Hodgson & Co.) 1,000 dies were disposed of about the same period.

With the disappearance of Sheffield Plate many of the partners in the old firms then engaged in its manufacture forsook it for other callings. We have had various members of the families of Creswick, Mappin, Roberts, Leader, Cadman, Watson, Gainsford, etc., etc., occupying the highest positions in other branches of industries and professions. The late Sir F. T. Mappin, Bart., and Mr. Samuel Roberts, M.P., have served with distinction in the House of Commons, whilst the Leaders have for nearly a century been associated with the literary and political work of the town. The late Sir Henry Watson, whose uncle, Thomas Watson, was in partnership with Thomas Bradbury in the year 1795 (see page 37), was for many years a solicitor, and chairman of one of the large manufacturing steel industries, which have made the name of our city so famous in this important trade all the world over. Mr. Robt. Robinson, a partner in the firm of Daniel Holy & Co. (see page 433), was the great-great-grandfather of Mr. Sydney Jessop Robinson, managing director of William Jessop & Sons Ltd., of the Brightside Works, Sheffield. A deed of partnership is in existence dated 1783, the signatures to which are those of George Woodhead, Daniel Holy, Robt. Fredk. Wilkinson, Joseph Drabble and Robt. Robinson.

Mr. W. Sissons* of Messrs. W. & G. Sissons, who succeeded to Messrs. Roberts & Cadman's business, finds that his dies are pretty well intact; but then this firm, being originally started only in 1784, would not have any great accumulation of dies of their own until, say, ten years later, which brings us to a period 40 to 50 years subsequent to the establishment of the industry. And then again, from a close examination of his firm's older

* Author of "Old Sheffield Plate."

catalogues, it is pretty evident that much as its founders led the fashions in the trade at one time, and excellent as were their designs, a great proportion of the work done was carried on by swaging, shaping, and raising by hand, which process of manufacture called for considerably more skill on the workman's part than that of piecing together the stampings of articles that were struck up from the dies.* Matthew Boulton's dies were also entirely dispersed in the year 1848. Some of these are in the possession of W. & G. Sissons, of Sheffield; there is no sign of the remainder being still in use amongst the many manufacturers who to day represent the plated trade of Birmingham, as formerly carried on at the Soho factory.

On the dissolution of the firm of Gainsford & Nicholson, in 1834, the number of dies offered by public auction irrespective of those sold by private treaty totalled 1072, the weight of metal alone in tools and dies was 20 tons; whilst 248 vices and 462 workmen's tools also came under the hammer.

THE CUTTING OF DIES.

In Leader's *Sheffield in the Eighteenth Century* an instance is cited of a cutlery operative "drifting into the work of cutting presses for horn scales and dies, and his artistic taste led him to design models and ornaments for silversmiths." This was Samuel Ellis, whose success enabled him to join, perhaps to become one of the founders, of the firm of Ashforth, Ellis & Co., which flourished in Hawley Croft, Angel Street, and Red Hill, from about 1770 to 1811. This testimony was furnished by Ellis's grandson, and though it does not preclude the possibility that designers, and perhaps die sinkers, were brought from other places, it seems, in conjunction with what we know of men like Samuel Roberts and his partner, George Cadman, not improbably typical of much that happened in Sheffield factories. In 1774, Samuel Ellis is described (and also Isaac Ellis, probably his son) as "cutler, mark, letter and figure maker, Holy (or Hawley) Croft"—apparently in conjunction with the plating works of Ashforth, Ellis & Co.; and other men were at the same time "cutlers and die sinkers," "button makers and die sinkers," "die sinkers and engravers;" while in 1787 we come across "William Lambert, silver cutler and ornament maker."

The only definite evidence bearing on the cutting of dies, points to the supposition that in this, as in other details, the silver manufacturers depended, in part at least, on local ingenuity and taste, developed by the requirements of the new industry. From an old book in the possession of T. Bradbury & Sons, some particulars are here given of dies and tools owned by this firm (of which a complete list is appended, with their cost) in the year 1771.

* The florid dies of the late Georgian period still in the possession of Messrs. Sissons, particularly for the making of large trays and waiters, are most numerous. At one time this firm employed no less than 13 die sinkers, who worked on their premises.

EARLY TRADE PRICES FOR TOOLS AND MATERIALS, FROM THE BOOKS
OF AN OLD SHEFFIELD PLATE MANUFACTORY.

On January 22nd, 1771, 27lbs. weight of dies were purchased for 11s. 3d. from "Thomas Webster," whilst for turning these dies, numbering 10 in all, he charged 8s. General tools also were purchased from him: 12 hammers, 1s. each; 1 "Mondril," 1s. 6d.; 6 pincers, 1s. 6d. the lot; 1 "Handlestake," 5s.; 1 pipe stake, 5s.; 1 bellying stake, 2 lbs. 6½ ozs., 17s. 3d. Planishing hammers were charged 1s. 10d. each. On January 22nd, 1771, "Samuel Ellis" was paid for cutting gothic waxlight foot die 15s.; February 12th, for cutting waxlight capital die, 16s.; February 15th, for cutting waxlight nosil die, 13s. And "Joseph Bright" at the same time was paid for 15 weeks' work at dies £9 17s. 4d. On September 12th, "William Oxley" was paid for 37 weeks' work at die sinking £30 1s. 7d. And on September 15th, 1772, "Joseph Bright" for 15 weeks' work, £9 17s. 4d. On December 4th, 1772, an addition was made to the factory in the shape of "a great stamp and apurtenances," with dies had of "William Fenton," costing £31 19s. 10½d.

The book referred to previously also contains a complete list of dies, numbering 175 in all, that were in use in the year 1775, with their descriptions some of which are of sufficient interest to reproduce in detail:—

	£	s.	d.
1 6-in. waiter "mettle" die	1	16	0
2 handle dies for tureen, "mettle" die ..	1	0	0
Ionick capital die	0	18	0
Vase ,, ,,	0	18	0
3 butter boat feet dies	1	10	0
*Coffee pot square foot die, "mettle" ..	0	2	6
,, cover & lip ,,	0	5	0
Vase and drapery foot die for candlestick ..	3	10	0
2 punch ladle dies	1	11	0
Cream ladle die	0	5	0
Salt Spoon die	0	5	0
2 cruet castor tops dies	0	10	0
Pint cup foot die	1	0	0
½-pint cup ,,	0	12	0
Oval cup ,,	0	5	0
*Tankard cover die	0	18	0
,, foot ,,	1	0	0
,, joint ,,	0	2	6
Mustard tankard cover die	0	12	0
,, ,, joynt die	0	2	6

* The bodies would be made by hand.

	£	s.	d.		£	s.	d.
Cruet frame handle, die	0	18	0	Coffee pot foot die	2	10	0
„ division die	0	18	0	„ large cover die ..	2	4	6
„ foot die	0	5	0	„ small „ ..	1	13	0
Dish cross lamp die	0	10	0	„ bottom socket die..	0	16	0
„ „ cover die ..	0	12	0	„ top „ ..	1	0	0
„ „ small cover die	0	9	0	„ joynt die	0	10	0
„ „ leg die	1	0	0	„ pineapple knob die	0	12	0
„ „ top shell die	0	14	0	„ spout die ..	3	0	0
„ „ foot die ..	0	10	0				
„ „ rest die.. ..	0	15	0				
„ „ shoulder bitt die	0	2	6				



Dish Cross, as described above, with adjustable sliding legs, folding arms and lamp for keeping contents of dish warm, made to take all sizes and shapes of dishes. One of the most popular articles made in the early plating days.

Date 1770.

Author.

	£	s.	d.		£	s.	d.
Tea kitchen foot die	3	1	0	small pine apple leaf	0	12	0
„ claw die	1	14	0	Pine apple die for Kitchen ..	0	16	0
„ handle die	1	10	0	Kitchen cover die	0	15	0
Shell die for Kitchen	0	10	0	„ rim „	2	2	0
large pine apple leaf	0	10	0	„ cock „	5	5	0

Mr. Dudley Westropp finds these “Tea kitchens” described as such in the lists of goods that went to be assayed at the Dublin Assay Office at the same period; possibly the designation “Tea kitchens” would be what became to be subsequently described as “Tea kettles.”*

It will be noticed that in the cases of coffee pots, mustard tankards, tankards with covers, etc., no mention is made of dies being in use for the bodies of these articles, which shows conclusively that they were in all cases either raised by hammering or turned up from sheets of metal in the earlier period. Another interesting feature is the fact that dies were extensively in use for the joints or hinges of the various articles, clearly indicating that in this respect hand labour was as far as possible avoided.

* Matthew Boulton, of Birmingham, writing to his wife from London in the year 1767, says:—“I am to wait upon their Majesties again as soon as our Tripod Tea Kitchen arrives.”

No mention is made in this list of 175 dies of anything applicable to the manufacture of tea pots, though dies for stamping the various parts of several patterns of coffee pots are detailed, showing that at this time teapots were not nearly so plentiful as they became subsequently. Those that were made about the year 1775 were manipulated almost entirely by hand.

Here follows a detailed list of the different workshops, their contents and values, all most carefully recorded with their costs. It is interesting to note that the various descriptions and names given to the articles are very much the same as those in use to-day in a silversmith's factory, and that a few of the articles enumerated are at this time still in daily use by the firm mentioned.

With a total value of £568 3s. 8d. for tools and utensils, the cost of the dies bears a very large proportion of the whole, viz., £247 11s. 8d. This is interesting as showing how very much more the silver plater relied upon the use of dies for his workmanship, even in the earlier days, than the contemporary silversmiths did.

IN THE COMPTING HOUSE.

	£	s.	d.
Coal pan	0	2	6
Writing Desk Leaf and Stools ..	1	8	0
2 Chairs	0	10	0
1 Mahogany Table	0	12	0
1 Oake Table	0	5	0
1 Case drawers	2	10	0
Glass Case, painting, etc. ..	5	10	3
5 Beams, Scales and Weights ..	3	0	0
Shovel, poker, Tongs and Fender ..	0	8	6
Almanack frame	0	1	0
Lancashire tools	2	0	0
	£16	7	3

IN THE WAREHOUSE.

	£	s.	d.
Case of Drawers	1	18	0
Pr. ,, Baggs	0	5	0
2 Stools	0	1	0
Large Table with 4 Drawers ..	0	14	0
Desk Box	0	3	0
Packthread Box	0	1	0
Cupboard and Shelving	1	0	0
Hammer and Pincers	0	3	0
Sheers	0	1	0
1 Pr Large Swages			
1 Doz. Blood Stones	0	18	0
8 Scrap Tinus	0	13	4
	£5	17	4

BURNISHING ROOM.

	£	s.	d.
Range and Fender	0	5	0
2 Large Tabs. with Drawers ..	0	14	0
3 Small Tables	0	9	0
Book Case	0	10	0
Steele Burnishers, etc.	1	10	0
Blood stone ,,			
7 Stools	0	3	6
6 Tin Caudks., 6d. each	0	3	0
2 Large Copper pans	0	10	0
	£4	4	6

CHASING ROOM.

	£	s.	d.
Range and Fendor	0	2	6
5 Vises	3	15	0
4 Bows and 3 Skins	0	8	6
2 Work Boards and Drawers ..	2	0	0
3 Stools	0	1	6
	£6	7	6

BITT PLATERS ROOM.

	£	s.	d.
Press and Stock, &c.	15	0	0
7 large Vises	6	2	6
2 Small ,,	0	8	0
5 Work Boards and 6 Drawers ..	4	0	0
1 loose Bench	0	3	0
2 Furnisses, &c.	0	10	0
Brushes frame and Spindle ..	1	16	0

BITT PLATERS ROOM—Continued.			
	£	s.	d.
Pr. large Sheers	0	10	6
Range and Fendor	0	5	0
7 Candks.	0	7	0
5 Bows and Skins	0	11	8
Shelves and Backs	0	5	0
Casting frame and Boxes ..	0	7	0
2 pr. hand Bellows	0	3	0
Lead picked Pott	0	1	8
7 Stools	0	3	6
Large packing box	0	8	0
Hand Vises, Sheers, Compass, plyers, Scissors, hammers, Files and Clams	2	8	6
	£33	10	4
CANDLESTICK GARRETT.			
	£	s.	d.
5 Vises	3	15	0
7 Skins and Slides	0	14	0
10 Stools	0	5	0
Turning Engine, &c.	1	10	0
Large Lamp and Dish	0	5	0
30 Rasers	5	5	0
14 Mandrels	1	15	0
7 Whip Cap Flutes	1	15	0
14 hammers	0	14	0
Files, Compases, plyers, &c. ..	2	10	0
Drawers and Work boards	3	3	0
Range and Fender	0	2	0
Corinthn. pillr. Mandrell	1	5	0
6 Stakes	1	4	0
	£24	2	0
MIDDLE CHAMBER.			
	£	s.	d.
4 Vises, Large	3	0	0
1 „ small	0	9	0
7 Skins and Slides	0	14	0
2 Large Work boards	3	0	0
10 Stools	0	5	0
Range and Fender	0	4	0
2 Large Lamps	0	10	0
22 pair Rasers	3	17	0
1 pr. small dble. Bellows	1	4	0
1 Harth and Tube Iron	0	5	0
2 pr. hand Bellows	0	3	0
Files, Compases, hand vises, plyers, &c.	4	0	0
2 Stakes	0	12	0
1 Screw Frame	0	2	6
12 hammers	0	12	0
8 Mallets	0	4	0
Small Tools	1	0	0
2 Saws	0	5	0
1 Small Lamp	0	2	6
	£20	9	0

CUTTING OUT CHAMBER.

	£	s.	d.
2 Vises	1	16	0
Work Board	0	10	0
2 Skins and frames	0	5	0
2 Stools	0	1	0
Sow Mettle plates	0	10	0
6 Ingotts	1	10	0
2 Furnisses. Barrs, etc.	1	5	0
11 Large Files	1	2	0
Mettle Saw	0	5	0
Casting Potts	0	15	0
Jas. Booth, Sett tools and Measures	0	10	0
Screw frame and Ring	0	2	6
3 Cand'ks.	0	3	0
5 Stamp Screws	0	1	8
4 Pr. of Large Tongs	0	6	0
Long plating Iron	0	2	0
Large Morter and Pestal	0	10	6
1 pr. large Stock Sheers	0	9	0
	£10	3	8

IN ROLING CHAMBER.

	£	s.	d.
1 Pr. 12 Inch rolers and handles	10	10	0
1 Pr. 8 Inch „ „	7	7	0
4 Pr. Small „ „	6	0	0
1 Pr. 8 Inch „ „ no frame	1	10	0
Range and Fender	0	5	0
Draw bench, etc.	2	0	0
Large Beam Scales and Weights	1	6	0
12 Wortles	4	4	0
2 Vices	2	2	0
Flye and Bench, etc.	8	8	0
3 Stools	0	1	6
1 Pr. Bitts	0	12	0
9 Pr. Chaps	@ 3/-	1	7
3 Bolsters	@ 2/-	0	6
91 Beds and punches	@ 5/-	22	5
Piercing patterns	1	4	0
Ind. Hawk Sett Tools	5	0	0
Roler Posts and Ironwork	1	0	0
Work Board with 2 drawers, Shel- ving, etc.	0	12	0
	£75	19	6

STAMP SHOP.

	£	s.	d.
1 Large Stamp	30	0	0
1 Small „	28	0	0
1 Hand „	1	5	0
3 Lead pans	0	7	6
Brushes and Frame	0	18	0
1 Work board	0	10	0
1 Furniss and Bars and plate ..	0	10	0
Large Shelf	0	1	6
Punches, Chisels, Raising Irons, hammers, &c.	0	5	0
7 pr. large Tongs, one pair small	0	17	6

STAMP SHOP—Continued.			£	s.	d.
2 Mettal Ingots	0	14	0
3 screw frames for do...	0	12	0
3 slides			
1 stamp hammer extra	0	16	0
(SMITHY.)					
1 Anvil and stock	2	9	1
1 hammer Large	0	1	6
1 Pair single bellows, etc.	2	5	0
Moods and Tools for knife hafts and caps and waiter feet molds	13	8	0
24 pairs haft Sinkers			
28 pr. Cap			
30 Razing Irons	0	15	0
5 fullers	0	7	6
6 pr. Iron Toughs	0	15	0
16 pr. leads for hafts	1	12	0
6 hollow punches	0	4	0
Punches and Mandrels for rod. hafts					
Razing Lead and Stone	1	8	0
			£88	1	7

BOIL SHOP.			£	s.	d.
Range	0	4	8
Grate	0	2	0
Iron plate	0	1	6
Stoole & Workboard & Sinkstone	0	6	0
Copper pans	0	7	0
2 Bucketts	0	4	0
2 Tubbs	0	8	0
1 hammer Small	0	1	0

BOIL SHOP—Continued.			£	s.	d.
1 Sait and Beck Iron	0	1	0
2 Simmons pans	0	5	0
1 hammer and 4 pair tongs	0	4	0
37 Stone 11 Lb. old mettal being broken, stamp hammers and Dies at	1	7	0
			£3	11	2

BRAZIERS SHOP.			£	s.	d.
2 Wood Clogs	0	14	0
2 Pr. Dble. Bellows	4	13	0
2 Harths, Tue iron and pipes	0	10	0
1 Range and Fendor	0	3	0
1 Furniss	0	5	0
6 Stools	0	3	0
large Work Board	2	0	0
4 Skins	0	4	0
2 Vises	1	15	0
1 Pr. Stck. Sheers	0	9	0
1 large lamp Dish and pipe	0	5	0
30 Hammers	2	10	0
12 knobs	0	18	0
and other small utensils	0	15	0
6 Wood Malls	0	3	0
35 pr. Swages	6	2	6
Morter and Pestol	0	6	0
Stakes, Wt., 3Cwt. 0qrs. 46 Lbs.	11	2	10
			£32	18	4

The names, "Room, Chamber, and Garrett," would no doubt owe their origin to the fact that as a rule factories for making Old Sheffield Plate were not especially built. Unoccupied dwelling-houses, the more commodious the better, were eagerly sought after, and converted for the purposes of making plate by the earliest manufacturers.

JANUARY, 1775.

	£	s.	d.
Compting House	16	17	3
Warehouse	5	17	4
Burnishing Room	4	4	6
Chasing Room	6	7	6
Bitt Platers' Room	33	10	4
Candlestick Garrett	24	2	0
Middle Chamber	20	9	0
Cutting-out Chamber	10	3	8
Roling Chamber	75	19	6
Boil Shop	3	11	2
Braziers' Shop	32	18	4
Stamp	88	1	7
	321	2	2
Dies	247	1	6
	£568	3	8

Commenting on the smallness of the size of such a Factory herein described, it must be borne in mind that as compared with the contemporary silversmiths and cutlery workshops of that period, in those days this would constitute "a large establishment." The stock in trade required by a silversmith did not include much in the way of dies, there would be no Bitt platers' room, no stamp shop, nor would there be any necessity for a special cutting-out chamber; whilst the stock in trade of a then cutlery works consisted of a few open hearths, various materials for making knife handles, sundry bars of steel and iron for forging blades and workmen's tools.

DESCRIPTION OF OLD FURNACES.

CASTING FURNACE.

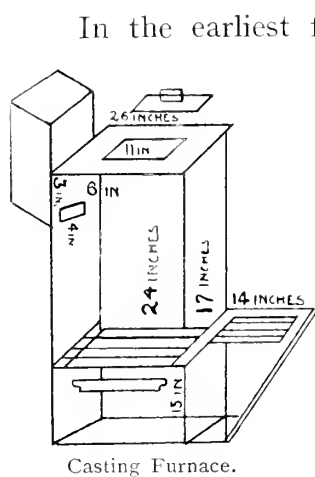

Casting Furnace.

In the earliest factories for making articles of fused plate, with the exception of the rawest of materials, everything would be produced on the premises. The casting furnace here illustrated (from the notebook of an Old Sheffield Plate manufacturer) was of course a very small affair in comparison with those in use to-day. The cokes for the fire and the crucible were put in at the top aperture marked 11", and filled up the space marked 24", as far as the draught hole. The outside bars marked 14" would be for resting the crucible on before and after being placed in the furnace. The ashes would be raked out from

the space marked 15" in the underneath chamber.

PLATING FURNACE.

Where the dimensions 19 × 34 are given will be seen the iron bars—a section of which is shown underneath. Upon these bars the fire was kindled, and on them the ingot to be fused was placed, this being inserted through the aperture marked 12". The underneath space was called the "ash hole," the ashes being taken away through the aperture marked 15". The inspection chamber door will be seen to the left; this fitted over the space marked 12", and it will be noticed that a small hole was left in this door so that the workman could carefully watch the ingot whilst the process of fusion was in operation.

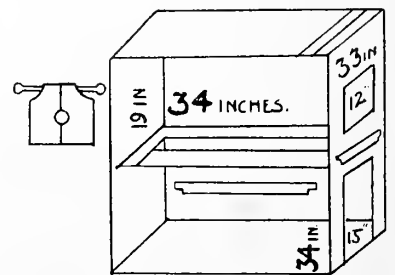

Plating Furnace.

STRIPPING PLACE.

In former times there were always appliances at hand for separating the lead and tin from the silver and plate materials known as "scrap," which accumulated during the process of manufacture. The "Stripping Place" contained a mixture the chief ingredients of which consisted of sulphuric acid together with sulphur. This solution when heated had the effect of completely disintegrating the silver, leaving the copper bare. The addition of common salt to this solution had the effect of sending all the silver to the bottom of the vat in the form of chloride of silver. In the diagram will be seen two baths capable of being heated, and a pipe which connected the upper with the lower bath. The article to be stripped was placed in hot solution in the upper bath, which bath after the article had been stripped was drained into the lower one when the bath was not in use. The sulphuric acid would absorb water, and the acid thus diluted would flow over from the upper to the lower bath, where it became concentrated and once more fit for use.

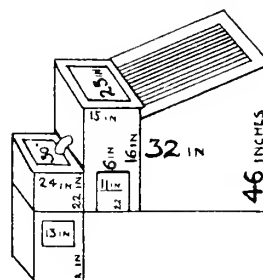

Stripping Place.

WHERE THE OLD SHEFFIELD PLATE MAKERS OBTAINED THEIR GLASS.

There has hitherto been a considerable mystery attached to this subject, and the much vexed question as to whether or not the Sheffield platers relied on Ireland for their glass is pretty definitely answered in the negative by the following list of manufacturers, from whom M. Fenton & Co. (and afterwards Watson & Bradbury) purchased their glass.

JOHN WITHEY, Sheffield.				JNO. DIXON—Continued.			
May 3, 1800	£21 4 0	1787-8	£208 19 0
GEORGE NICHOLS, Sheffield.				1789	101 0 9
1811	13 17 4	1790	164 9 1
1813	9 7 4	1791	101 3 6
WM. BEATSON & Co., Rotherham.				1792	154 7 11
1801	10 5 8	1793	137 17 10
1802	16 0 4	1794	120 11 10
1803	45 10 9	1795	101 6 9½
JNO. DIXON, Whittington, "Glass House";				1796	90 17 7½
also described as JNO. DIXON, "at Whittington."				1797	60 6 3
1779-81	236 15 9	1798	45 8 10
1781-2	166 12 2	1799	66 13 10
1783-4	139 11 0	1800	227 17 7
1785	166 14 6	1801	18 15 5
1786	85 18 10	1802	30 18 7
				1803-6	118 10 9
				1807	50 5 7

JOHN BENSON, Dudley.				JONES, SMART & Co., Birmingham.															
1803-4	128	0	1	1799	72	1	0 $\frac{1}{2}$				
1804	219	7	6	1800	145	9	5 $\frac{1}{2}$				
1804-5	275	0	4	1800-1	195	0	5				
1805	217	11	11	1801	59	4	9				
1805-6	158	18	7	1802	188	13	5 $\frac{1}{2}$				
1806	323	19	4	1803	152	7	11				
1807	432	1	6	1804	168	7	6				
1808	455	19	2	1805	162	9	4				
1809	687	0	0	HUGHES & HARRIS, Birmingham.				1798	45	3	9
1810	684	18	3	1800-1	164	19	3				
1811	745	9	3	1801-2	183	7	11				
1812	581	12	7	1803	191	19	7				
LEE & LARGE, Dudley.				(See Hughes & Fearon.)															
1804-5	57	2	4	HUGHES & FEARON, Birmingham.				1805	31	12	6
1805	34	2	0	1806	113	2	11				
WM. LARGE, Dudley.				BRUETON GIBBONS, Birmingham.				1807	130	12	6				
1805-6	55	0	11	1808	71	14	7				
1806	160	5	6	1809	167	6	4				
1807	229	3	8	1810	2	11	0				
1808	71	11	5	(See Danl. Hughes & Co., and Fearon, Collins & Co.)				DANL. HUGHES & Co., Birmingham.							
1809	125	16	11	1810	92	18	8				
1810	308	0	9	1811	26	4	6				
1811	283	16	4	FEARON, COLLINS & Co.				1811-12	56	9	8
1812	51	0	5	I. & M. JONES, Edgbaston Street, Birmingham.				1800	53	11	0
LARGE & HODGETTS, Dudley.				ISAAC HAWKER & SON, Birmingham.				1804	33	1	10				
1806	£60	18	7	1784-5	13	8	6				
1807	31	4	4	1788	6	1	8				
1808	5	5	0	1791	18	8	0				
JAMES SMART, Birmingham.				(See Jones, Smart & Co.)				1792-4	66	9	5				
1794	57	9	8	1794	57	9	8				
1795	141	11	11	1795	141	11	11				
1796	175	0	8 $\frac{1}{2}$	1796	175	0	8 $\frac{1}{2}$				
1797	125	15	0	1797	125	15	0				
1798	114	4	2	1798	114	4	2				
1799	128	11	9	1799	128	11	9				
(See Jones, Smart & Co.)				SHAKESPEAR, JOHNSON & Co., Birmingham.				1806	23	4	0				
(See Jones, Smart & Co.)				JOHN ALLEN, Birmingham.				1812	149	2	8				
(See Jones, Smart & Co.)				(See Jones, Smart & Co.)				(See Jones, Smart & Co.)				(See Jones, Smart & Co.)							

It is of much local interest to learn that as early as the year 1779 the small village of Whittington, some few miles from Sheffield, was turning out glass to the value of £236 in one year for the requirements of certainly one

house in the Old Sheffield Plate trade. There are good grounds for presuming that the other Sheffield manufacturers would also be patronising the same manufactory. This Derbyshire industry, which must have been a large one, had apparently ceased by the year 1808, as we find that from about this date the Dudley and Birmingham manufacturers had pretty well monopolised the whole of the glass production, so far as the books of the firm referred to can be traced. Extracts have only been made between the years 1779 and 1812, as being perhaps the most interesting. This period embraces most of the patents, improvements and inventions, also the culminating point of artistic design in Sheffield Plate.

Mr. R. E. Leader says: "There was a glass house at Bolsterstone, near Sheffield (a curious situation for such an industry) whose wares towards the close of the seventeenth century had attained a high reputation. A Worcestershire man, Richard Dixon, who had been employed there, removed in 1704 to Whittington, where he established a glass factory, which was continued by his descendants through three generations. The John Dixon, who supplied glass to the Sheffield silversmiths from 1779 to 1807, was the grandnephew of the founder.* In 1740 others of the Bolsterstone company set up glass works at Catcliffe; and an Attercliffe glass house is often mentioned in the parish register."

The Beatsons of Rotherham, recorded in the above accounts (1801-3), were "celebrated for the beauty of the flint glass articles they produced."† It is probable that George Nicholls and John Withey, Sheffield, were not makers. The 1817 Directory gives George Nicholls and Esther Withey as glass cutters, both in Norfolk Street.

That the Sheffield manufacturer ever used so-called "Waterford crystal glass"—as has often been supposed—research in Ireland by Mr. Dudley Westropp has gone far to disprove. "In a general way," says Mr. Westropp, "it may be taken that during the period of which you are writing the Irish people imported a good deal of their glass from England, whilst strangely enough the products of their own manufacture were to a very great extent disposed of in America,‡ and it has not been found that the makers in Ireland ever competed with the Birmingham and Dudley manufacturers in the supplying of glass for Old Sheffield plated goods."

* Gilbert Dixon, attorney clerk to the Sheffield Cutlers' Company from 1736 to 1777, was grandson of the first Richard Dixon, and uncle to John Dixon. There is a reference by him to glass bottles made by his father, in the History of the Cutlers' Company, Vol. I, p. 295 n.

† Guest's "Rotherham," p. 687.

‡ Vide "An Essay on the Manufactures of Ireland," by Thomas Wallace, Dublin, 1798; see also Proceedings of the Royal Irish Academy, Vol. XXIX., Section C, No. 3, "Glass making in Ireland," by M. S. D. Westropp.

The more scientific method of treating the materials used in the making of glass has resulted to-day in the production of the highly polished and prismatically brilliant articles now in general use. The various tints that will be noticed when examining specimens of old glass are due to impurities in the sand and alkali. The main reason for the absence of colour in modern glass is the higher quality of ingredients used in its manufacture.

Collectors prefer a piece of Sheffield Plate with the old crystals intact. Articles—especially Epergnes—minus their original glasses are not valued by connoisseurs. Although getting scarcer every day a few of the sets of old crystals used for centrepieces and dish rings are still to be met with, which, on account of their varied shapes and rich cutting, are much sought after. These glasses were most expensive to produce, and cost anything up to £5 or £6 the set. The Salt and Sugar Basin glasses, some of which are illustrated in this volume, were again very costly, as also a complete set of bottles for a table cruet.

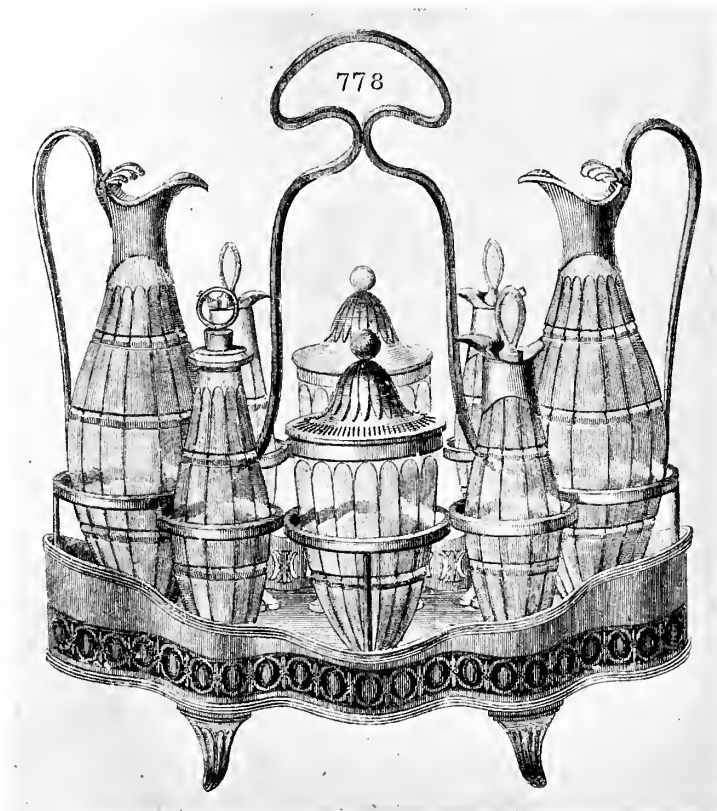

Design reproduced from an Old Sheffield Plate Catalogue of D. Holy, Wilkinson & Co., about the year 1790, showing the extent to which glass was then used for Cruets, etc., by the manufacturers (see also page 415).

PART IV.

PROCESSES, PRACTICES AND INVENTIONS.

APPLICATION OF GOLD IN THE MAKING OF OLD SHEFFIELD PLATE.

That a general trade existed in the Old Sheffield Plating days for manufacturing articles from fused gold plate will not bear the light of investigation. Such a process, considering the great value of gold and the greater heat necessary for bringing it to the fusing point, would be far too risky and costly a method to obtain much general favour with the manufacturers except in a few isolated instances, and for special requirements. It will occasionally be found on close examination that some of the Old Sheffield gold-plated articles have been subjected to the process known as mercurial or fire-gilding, after being made from fused silver plate and finished in the orthodox fashion. The articles most commonly to be found to-day that are gilt are usually dessert stands and épergnes, and such as must of necessity have been subjected to the process of fire-gilding.

In order to gild the interiors of pitchers, sugar bowls and cups, the Sheffield plate makers adopted the following method:—An amalgam was made by boiling the gold in about five times its weight of mercury in an iron ladle which had been coated with whitening and water and then dried. The amalgam having been poured into cold water and brought to a semi-fluid condition, was put into a leather bag and squeezed to get rid of the mercury. This operation forced the mercury through the pores of the leather and left the gold in the bag. The proper consistency of the gold was about that of stiff clay, and it was divided into portions sufficient to cover the article which it was designed to gild. As there was no chemical affinity between the gold and the object to be coated, it was necessary to use a solution of nitrate of mercury, made by mixing a quart of nitric acid with a tablespoonful of mercury. When this nitrate of mercury was put on the copper, its surface at once became an amalgam, and to this surface the other amalgam of gold and mercury closely adhered by means of molecular attraction of the fluid metals to each other. The amalgam was applied after the interiors of vessels had been coated with the nitrate; then the vessels, with the gold side up, were placed in open pans and set over a coke fire, the heat of which caused the mercury to evaporate and leave the gold only. This process was known as fire-gilding, and is

practically the same as that described in Benvenuto Cellini's treatise on Goldsmithing. It is more costly but far more lasting than the modern method of depositing the gold by electricity.

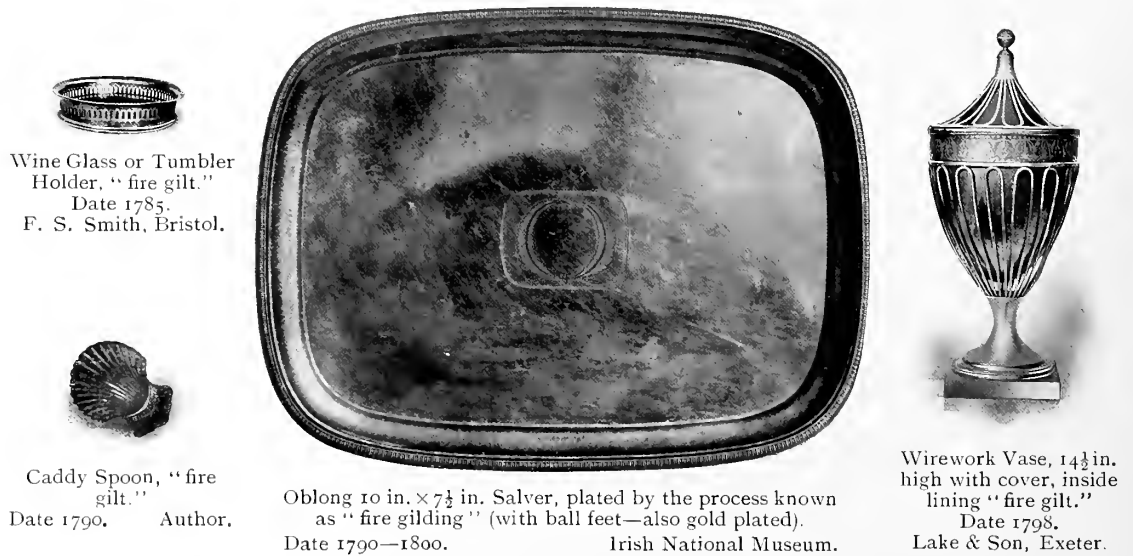

Wine Glass or Tumbler
Holder, "fire gilt."
Date 1785.
F. S. Smith, Bristol.

Caddy Spoon, "fire
gilt."
Date 1790. Author.

Oblong 10 in. \times 7½ in. Salver, plated by the process known
as "fire gilding" (with ball feet—also gold plated).
Date 1790—1800. Irish National Museum.

Wirework Vase, 14½ in.
high with cover, inside
lining "fire gilt."
Date 1798.
Lake & Son, Exeter.

PROCESS OF CHASING.

In all the different periods and styles through which the manufacture of Old Sheffield Plate passed, decoration by chasing was continuously resorted to by the trade.

Whether by the aid of dies, beds and punches, engraving, chasing in high or low relief, ornamentation of some kind seems formerly to have always been an essential feature in the production of plated goods. From the earliest days of the industry up to the time when engraving was introduced as an ornament about the year 1789, what is technically termed by the public "repoussé work" or, to use a trade definition, "chasing in high relief," was the more common form of decoration. After this date flat chasing—closely resembling the engraved ornamentation in its detail—became very prevalent. After the introduction of the more ornate borders and mounts—and by the year 1820 these had grown to enormous proportions—we find an outburst of decorative chasing in the form of heavily laden scroll, foliage and flower designs, which far exceeded anything that had been previously undertaken in this connection during the entire progress of the industry. The articles made in this later period will be found to be very similar in design, though not in execution, to those in vogue when heavily chased patterns first became general in the earlier days of trade.

This florid decoration is to be noticed on coffee pots, two-handled porringers, and cups produced previous to the year 1770. The heavily mounted entirely flat chased large trays and salvers made between the years 1815 and 1830 are articles perhaps more sought after than any others in Old Plate. Fine specimens in perfect condition bring large sums of money. No collection is quite complete without one or two of these varieties.

The process is best explained by the illustration. Having first of all been carefully flat-hammered, the article to be chased—in this instance a tray—is embedded in warm pitch, which is then allowed to cool down



22 in. Flat Chased Oval Tray, with silver mounts, and wood bottom secured underneath the plate of Tray.
Date 1795. Oswin & Co., Hereford.

until it sets quite hard. A great deal of care has to be exercised in the preparation of this pitch to acquire the hardness and solidity necessary for the purpose of chasing. An indented tracing of the desired pattern, pricked on paper, is then carefully sprinkled with chalk and afterwards slowly rubbed over the surface of the article. Afterwards the outlines of the pattern, now clearly delineated, are traced in by the aid of the "steel pointer." The workman now selects his punches and indents the outline on the surface of the tray by tapping home the various lines and curves which constitute the main features of the design to be reproduced, afterwards carefully matting over with specially delicate punches the finer details of the pattern, such as the veins of leaves, petals of flowers, etc., etc. The reason

for bedding the articles in pitch when chasing is in order to keep them in their proper shape during the process, otherwise the force used in the hammering has the effect of knocking the article completely out of the straight.

When chasing in very high relief it was necessary that Sheffield plated articles should have an extra deposit of silver, so as to prevent the silver breaking away and thereby exposing the copper foundation ; but this chasing in very high relief was consistently carried out in the old plating days, notwithstanding there being always the risk that should the definition become too bold the silver might stretch and break.



Illustration of the process of Chasing.

PLATING ON BOTH SIDES OF THE INGOT.

One of the great puzzles that both the trade and the public have had to contend with has been caused by the too readily accepted theory that not until sixty years after the birth of the process was the discovery made of the possibility of plating on both sides of the ingot. Scrutiny of original notes (written in 1850), from which apparently this idea emanated, and minute examination of earlier specimens, point to the conclusion that the assertion is incorrect. Valuable as the records are, the writer died before he had properly revised or corrected them. Other instances have been detected in the notes of clerical errors in dates which the chronicler would doubtless eventually have amended had he survived to publish his memoirs in book form. It would be late enough to presume the invention of double plating as occurring between the years 1763 and 1770.

Perhaps the fact that after the discovery of the possibility of plating on both sides of the ingot this method was not at first very generally resorted to (and also that at all times, during the various periods of manufacture, articles plated on one side only were made for the sake of economy), may have led to the supposition that the process itself was not discovered until a considerable time after the establishment of the industry. Old records lead one irresistibly to the conclusion that with increased improvements in the methods of constructing their furnaces (no doubt greatly aided by the experiments then being conducted in Sheffield by Huntsman for the treatment and manufacture of cast steel, between the years 1760-1770), the attainment of the method of making double-plated sheets would not be long delayed after the industry had once been firmly established.

Be that as it may, silver in earlier days being such an expensive item in the process of manufacture, double-side plating would not at first be very generally adopted for the majority of the articles in domestic use, even had the process been discovered at that time.

It would be superfluous for the platers always to cover those parts of the metal that were not exposed to view with silver. The under surfaces of waiters and trays, the inner sides of dish warmers, etc., etc., would usually be made from single side plated metal, and coated with tin after the invention; but entrée dishes, cups, beakers and articles generally associated with food or drink were the better for double-plating, and in such instances the extra cost would be willingly borne by the users.



10 in. Salver, with silver filled mount, and tinned under side,
by Watson & Bradbury.

Date 1790.

Author.

As regards the early period salvers and inkstands that one finds with the borders or swages made from two pieces of fused plated metal laid back to back, and exposing to view plated surfaces both on their obverse and reverse sides, attention is drawn to the fact that they were so made primarily with the idea of giving strength, and not, as is generally supposed, entirely with the object of exposing a silver surface to view on the borders when reversed. The sole attainment of such an object would be out of all proportion to the extra cost thereby incurred.

As proof of the above assertion, illustrations are here given of this back-to-back method of strengthening waiter mounts, made years after the invention of the process of double-plating (1790-1800), and yet having a tinned underside plate. Although it is interesting to note that in this instance the borders having been fashioned purely with the object of giving strength from two pieces of fused metal laid back to back, the plate has been made from one sheet only of single-side plated metal. In some cases there are also to be found salvers with the plates consisting of two sheets of



Reverse of Salver, showing a duplicated strip soldered underneath mount, for strength, with an outer plated surface.

single sided plated copper, laid back to back, the outer plated surfaces only being exposed, but on account of the weight entailed this method of manufacture was usually only applied to waiters and not to other articles. Joseph Hancock is said to have made his tankards in this way about the year 1755, but articles manufactured entirely from double sheets of metal are very rarely to be met with, the method being by no means an unqualified success.



8 in. Salver, with chased front. Made from two sheets of single side plated metal, soldered back to back and secured between the edges of the swage and mount—also in duplicate. In this instance the mount and swage are conjointly cut in the same die, a method abandoned after the introduction of silver mounts. Probably made before the invention of double side plating.



Reverse of 8 in. chased Salver. The under side of swage being of thick metal and for the purpose only of giving strength, has not been struck home in die, as is the case with the front side, which is stamped from metal of a much thinner gauge.

Date 1760.

Author.

Another reason for the duplicating of the mounts on salvers was that when stamping them from dies that were broad and ornate, as is the case with the well-known "shell pattern" (and its innumerable variations), the strength of metal required if struck up from one piece only, would be so thick as to present difficulties in the stamping process. Hence by fastening together two pieces of metal varying in thickness there was obtained at the same time both great rigidity in use and sharpness of detail (see illustrations above).

When the mounts had been firmly secured together, a small, light soldering iron was used for soldering up the crevices on the extreme outward edges of the salver where the two plates of metal had been borne together. The solder itself was chiefly composed of tin, so as to resemble more closely the colour of silver.

After scraping away the superfluous solder and carefully burnishing round the edges of the waiter, the line of demarcation would be quite imperceptible, the raw edges of the copper being entirely covered up by this process.

In the latter days of Old Sheffield Plating the cheaper manufacturers almost invariably worked up their metal plated on one side only.

DEPOSITS OF SILVER.

In the earliest days of the fused plated industry the amount of silver deposited was of a very liberal thickness, varying from 10 to 12 ounces of silver to 8 lbs. of copper, and this, too, for plating on one side of the ingot only.

The proportion of silver to that of copper varied according to the will of the manufacturer or the whim of the purchaser; but the greatest deposit ever used was the one mentioned later as in use when deep cut engraving was first introduced, viz., 24 ounces of silver to 8 lbs. of metal. At the zenith of his success, Samuel Roberts, about the year 1798, determined to improve both the quality of the plate he used and advance the prices of the articles that he made. Unfortunately it is not known to what extent he increased his deposits of silver or what was the generally accepted standard in the trade at that time. However, it suffices to say that this metal, described by him as "Bell metal," no doubt on account of its bearing his trade mark (the bell), did not find general favour with the public because of the extra price necessarily charged for it, and he soon reverted to using the regular trade deposit of that time, averaging probably about 8 to 10 ounces of silver to 8 lbs. of metal.

On the introduction of the rubbed-in silver shields, about the years 1810-1815, the deposits were again considerably lessened, and we find as a general rule that these were then in the proportion of 5 to 7 ounces of silver to 8 lbs. of metal. (All these later deposits, with the exception of the trays for bright cut engraving, were for plating on both sides of the ingot.)

Dish covers had of necessity to be made from metal the silver on which was of an extra strength, on account of the amount of raising and hammering to which they were subjected, and for single-side plating the amount of deposit averaged 8 ounces of silver to 8 lbs. of metal, and for double plating 12 ounces of silver to 8 lbs. of metal.

In the latest period it is sometimes found (as was the case with the French manufacturers) that marks were struck on articles—usually dish covers—indicating the proportion of silver to the copper. There are specimens of Old Sheffield Plate bearing the following words: "Sheffield Light Silver Plating, 50 dwts. (and even 40 dwts.) to 8 lbs." This is a lighter deposit of silver than is found on best electro-plate to-day. And

again, are the words, "Best Sheffield Heavy Silver Plating," "80 dwts. to 8 lbs." These marks, it will be found, are usually accompanied by the name of a retail firm of London jewellers now defunct. Perhaps the articles were made with such light deposits under pressure of foreign competition?

INVENTION OF PLATED WIRE.

When plated wire first came into use, in the earliest days of the industry it was manufactured from hollow tubing, formed of either copper or brass,* around which a coating of thin fused plated metal was secured, but on account of its inferior resisting powers in wear it does not appear to have been very generally adopted. About the year 1768 solid plated wire was introduced, being obtained from the rolling mills in strips. At first its manufacture was complicated, and consequently expensive; even greater care had to be exercised in the preliminary stages of its preparation than was the case with fused sheet metal. A strip of fine silver $\frac{1}{32}$ of an inch thick was bent to fit a copper bar about 5 inches long by 1 inch thick which had previously been drawn into a round form by the aid of a whortle. The two metals were then wired together and united by fusion. After being plated the bar was repeatedly drawn through a whortle until it assumed the form of wire. This also gave it rigidity and smoothness, whilst at the same time it brought the two edges of silver together, these being purposely left slightly apart to facilitate the process of fusion.

This invention marked an advance in the process of manufacture. Articles made hitherto, such as waiters and all kinds of dishes, soup tureens, cake baskets and similar goods are to be found with what is termed a "self mount," i.e., the borders were struck from dies which had the mounts and swages cut conjointly, and as these mounts were not soldered on separately, they had no great resisting power when in use. Many articles made previous to the invention of plated wire show to-day cracks extending from their outer surfaces for some distance along their bodies. To some extent these borders were at times strengthened by duplicating the metal on the edges and soldering a strip underneath the mount (struck separately from the borders of the dies of the articles themselves), or by leaving a fash on the edge of the stamping which was turned underneath the mount by the aid of a burnish. The outer edges of these goods were never so strong as when a separate piece of wire was soldered on.

This method of plating solid wire was superseded about the year 1780 by a simpler form of procedure attributed to two young men,

* It will be found that brass was extensively used by the Sheffield Platers throughout the whole period of the industry, but always placed out of sight. Inner tubes for telescopic candelabras, locks for entrée dishes, bottoms for tankards, and screws for candelabra were usually made of this material.

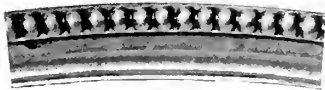

Section of fused plated drawn wire, with bead decoration, from the mount of a cake basket made about the year 1773, by the earliest method. The bead decoration was produced by the aid of a die.

Pierced and Chased 14 in. Cake Basket, showing the border badly damaged, made before the introduction of strengthening mounts.
Date 1765. Butt & Co., Chester.



Plated drawn wire shown in use for strengthening the inside of a teapot lid, made about the year 1783. By Wilks' method. See also mount for Jug, page 86.



Cake Basket reversed, showing the border without any protection to the edges.

“Wilks and Moteram,” who were, formerly, apprentices of Matthew Boulton, and they are reported to have withheld the secret during their term of apprenticeship. After serving his time in Birmingham, Wilks eventually came to Sheffield and commenced business with Mark Dixon in the year 1785.

The method adopted for this process was as follows :—Having prepared a round bar of copper 1 inch or more in diameter, and made it perfectly clean by filing, etc., a nick was made near each end and all round the bar. Then a sheet of fine silver was rolled and cut to a given proportion, and bent round, the edges being brought together, or rather, one laid over the other. These edges were now united and formed into a tube by rubbing them with a long double-handled burnish on a hot piece of iron firmly secured. This tube had then to be perfectly cleansed from all impurities inside, drawn over the bar of copper and forced into the notches cut at the ends of the bar, the air, as far as possible, having first been carefully excluded. The two pieces of metal, i.e., the solid copper bar and the silver tube covering it (notice the absence of any substance in the form of a flux), were then made hot and carefully burnished from end to end of the bar, any air that still remained confined being allowed to escape through a small hole pricked at either end of the bar. The whole was now finally sealed up by the process of annealing and again burnished whilst hot. Afterwards it was drawn through the whortles,* by which process the wire could be pulled out to an almost indefinite length, and at the same time take any form of pattern to which the holes in the whortle had been shaped. The illustration shows an old burnish, which was formerly constantly used for this purpose, and which has been, fortunately, preserved until now, although it has not been in use for upwards of 60 years past. Out of this process of plating wire one cannot help thinking that the idea of rubbing in the silver shield must have originated (see Page 93). The reader, by studying carefully the details of these two processes, will at once be struck by their great similarity. Both methods, it is stated, were evolved from the brains of the same individual, viz., Wilks.



Burnish in use for making plated wire, 21 in. long.

* See pages 106 and 107.

INTRODUCTION OF SILVER EDGES.

The indefatigable Samuel Roberts and his partner, George Cadman, were the first to introduce the silver threaded edges, almost immediately after they started in business for themselves in the year 1785. This method in some instances supplemented the use of plated silver wire, and also gave increased durability to an article.*

The method of forming the edges consisted of drawing through a hole or whortle a hollow wire or very thin strip of silver, which corresponded exactly in size with the edges of the article that it was intended to cover up. At the same time this process shaped up the silver thread into a groove, thereby rendering the operation of soldering on these silver edges more easy.

Matthew Boulton, of Birmingham, excelled in the manipulation of these silver threaded edges, and brought the art to a great degree of perfection. Occasionally he stamped the words "SILVER BORDERS 

Very soon after the introduction of silver threaded edges, and about the year 1789, there came into more general use the system of stamping separate mounts for dishes, waiters, tureens, salt cellars, etc., etc., such mounts being struck up in thin silver from dies cut in long strips, and when filled with solder composed of lead and tin, they could readily be bent into any shape or form required. The method of filling these mounts was as follows: After carefully brushing the outside edges with a mixture of glue and whitening, the mount was laid in a plaster mould or bed of Calais sand. Into the mount the solder was then poured in a molten state with the aid of a small ladle. Now a hot soldering iron of the style here shown was gently rubbed over the surface of the molten solder, powdered resin being requisitioned with the object of making the mount "tin" more readily and causing the solder to flux. Whilst the solder was in a molten condition, a round piece of wood dipped in oil was used for gently rubbing over the surface of the solder, so as to ensure its having a perfectly flat surface, and thus enabling the edges of the mount, which had been left on by the stamper, to be more evenly removed. This could be quite easily accomplished by the aid of a burnish, pressure with the thumb, and subsequent filing.



Soldering Iron, used when filling silver mounts.

* This new form of edge was not for the object of superseding plated wire for strengthening purposes, but for protection in use, and also for enhancing the appearance. Being composed of sterling silver, threaded edges never disclosed a raw copper surface—after years of wear—as was the case when plated wire had to be used.

But not until some 10 or 15 years later was there any great variety in the styles of these mounts : they were at first mostly confined to those slightly ornate in appearance, such as the bead, thread, straight and slant gadroon. By leaving on a fash or outer edge of silver when stamping these silver mounts the workmen soon became skilled in turning such edges over, so as to hide the raw copper, without the necessity of always making use of separately soldered on silver threaded edgings. The articles to be found to-day with silver borders to them are about equally divided between those that have been "lapped over" and those "soldered on separately." For instance an entrée dish with a plain straight gadroon edge to it would, in all probability, have a lapped-over edge; whilst one with a complicated form of shell and gadroon ornamentation and a shaped-up body could be more easily dealt with by having the edgings soldered on separately.

The commonest quality of old plate is to be distinguished by a bevelled edge at the back of the mount, clearly discernible, which distinctly shows the solder, where in the two former cases silver only is to be seen.



1. The earliest method. Two pieces of metal having been laid back to back and soldered up, the extreme edges were tinned. 1755 to 1785.

2. Cadman's method first adopted in 1785. The edge of border has a separate silver shaped up strip soldered on for protection, whilst the feet are protected with silver fronts the edges of which are burnished over.

3. Common border of the latest period, showing the bevelled edge with solder slightly discernible.

The three methods of treating the borders of Silvers.—The white margins shown in the two lower illustrations are for the purpose of more clearly defining the edges of waiters.

It is no indication of inferior quality to find the absence of these silver threads ; in fact in many instances, in the later period, some makers so cleverly manipulated their edges that it is only by the minutest examination that any line of demarcation between the bodies and mounts of various articles can be discerned.* On the whole, however, the so-called lapped-over or soldered-on silver edge is the finish that appeals most to connoisseurs when selecting an article of Old Sheffield Plate.

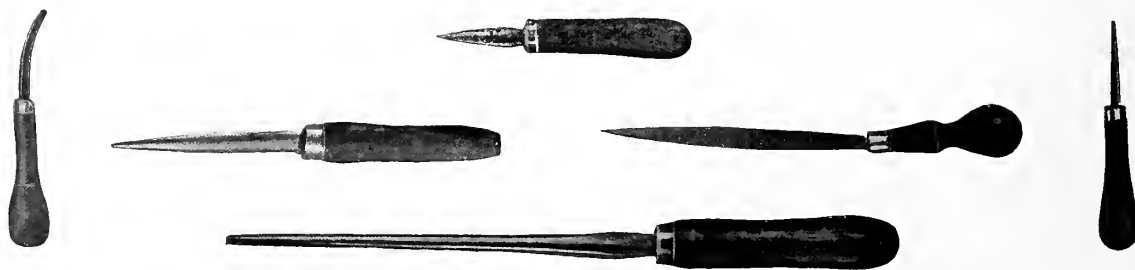

Varieties of Burnishes used by workmen to close up the joinings of silver mounts, handles and feet, and also for lapping over the silver edges of mounts, &c.

Having been the first to introduce and make use of silver edgings for mounting on to all the Sheffield plated articles that he made for close on forty years, Samuel Roberts, in the year 1824, took out a patent to do away with them altogether. His object being, as he describes it in his specification of manufacture, so to imitate sterling silver wares that it would be impossible even for an expert to discriminate between silver and plated articles when they were placed side by side. His method was carried out as follows : After filing the outer edge of the article until it took the shape of the ornamented indented silver edge, though somewhat less in size, a silver thread of the required thickness was hard soldered on to this outer edge. It was carefully flat-hammered to the breadth and strength required for its purpose, thereby now making the outer edge to extend a little way beyond the ornamented silver edge ; soft soldering up of the two edges was then carried out in the usual way. After that the projecting part of the hard soldered silver outer edge, which now extended beyond the ornamented silver edge, was filed off and the two edges were carefully burnished together until the seam actually disappeared.

* Articles finished in this way must not be confounded with the cheap bevelled edge form of finish on the backs of mounts (as shown in illustration 3 on previous page).



Early Coffee Pot, made before the invention of plating wire, showing the method of turning over the outer edge of lid to form a mount and secure the bizzle. The body is also turned over on the top to form a mount and to strengthen the article.
Date 1758-1768. Author.



Section of Tea Caddy, showing silver filled knob, silver protecting edge to base, and feet stamped in thin silver (with plated metal backs) filled with solder.
Date 1789. Author.



1/2-pint Sauce Boat with Roberts' patent silver edges. This article is illustrated in Roberts & Cadman's pattern book and described as "fluted antique." It is almost impossible to tell until minutely examined whether it is of plate or solid silver.
Date 1825. Author.



3/4-pint Sauce Boat, in Silver, showing great similarity in design to the Old Sheffield Plated one, by William Sampel.
London Hall Mark, 1763. Jarvis, Richmond.

ILLUSTRATIONS SHOWING VARIED FORMS OF MOUNTS.



Jug, showing method of protecting top and lip with a plated drawn wire mount.
Date 1783.

INTRODUCTION OF ENGRAVING.

About the year 1789 bright cut engraving came into fashion for teapots, coffee pots, teapot stands, waiters, etc., etc., Samuel Roberts being also credited with this novel form of decorative invention. At first the engraving was performed on articles plated on one side only, necessitating a huge deposit of no less than 24 ounces of silver to 8 lbs. of metal, and with such a thickness of silver the process of bright cut deep engraving could be carried out with impunity. Specimens of this class of workmanship, however, are extremely rare. The tray here illustrated is an example. The surface is in as perfect condition after about 120 years' wear as when the article was originally made.



22 in. Heavily Plated Silver, with bright cut deep engraving, without a separate silver shield, by Roberts, Cadman & Co.
Date 1795. Elkington & Co., London.

The process of engraving is so common and so nearly allied to that of chasing that it will be unnecessary here to give a full description of it. The article to be engraved was not embedded in pitch, as the thrust of the engraver's tool would be too light to force it out of shape. As with chasing, the pattern was chalked and defined on the article before engraving, the only difference in manipulation being that the pattern was scooped, or cut, out of the metal with small, sharp tools, resembling somewhat surgical instruments in their varieties of styles. These had to be constantly sharpened when in use.

So nearly alike are articles flat chased to those that have been subjected to the process of engraving, that after being in use for some years and the sharp edges consequently smoothed down, the only safe way of deciding if flat chasing has been carried out is to reverse the article and to note whether the pattern is outlined underneath. If this be the case, then it has obviously been flat chased.

NECESSITY FOR SILVER SHIELDS FOR ENGRAVING CRESTS,
MONOGRAMS AND INSCRIPTIONS.

An insuperable difficulty that had to be overcome by the early plate manufacturers was that presented by the necessity for making provision for the engraving of crests and coats of arms. Instances of pieces of silver plate made in the 18th century, unadorned with crests, coats of arms, etc., or initials are so rare as to form an exception to the general rule. This indicates a general desire by the public to have plated goods capable, like silver, of bearing devices. Had this work been undertaken by the manufacturer whilst an article was being made, the flat chasing-in of a crest or monogram, though a more costly undertaking, would not have presented any very great difficulty, and occasionally we find that this method has been carried out entirely satisfactorily.

The articles had of necessity to be selected from a manufacturer's stock before being exposed for sale to the public in a retailer's establishment, and there being no rapid transit of small parcels to and from the various factories as is the case to-day, the engraving of the article in the town wherein it was purchased became necessary. We therefore find that for about the first 25 years after the establishment of the industry it was requisite to deposit a much heavier proportion of silver when making the articles than was the custom after the invention of the ingenious devices, adopted later on, for thickening with silver the part only where such engraving was likely to be required.



3-gill Teapot, showing chased decoration and shield, before the method of soldering-in silver shields was adopted, by J. Hoyland & Co.
Date 1770. Author.

Every town of any size possessed its local engraver who would work generally for the various retailers in his district. In London the retail jewellers would have sufficient work on hand of this kind for each to support engravers, who worked on the premises.

Perhaps nothing brings home to us more clearly the extent to which the best families in the land purchased the Old Sheffield Plate than the innumerable crests and coats of arms still to be found on the old pieces. The execution of them is in almost all cases superb, and no true collector would attempt to obliterate or substitute his own crest or monogram for that to be found on an old piece. Any erasure of this kind, no matter if the article

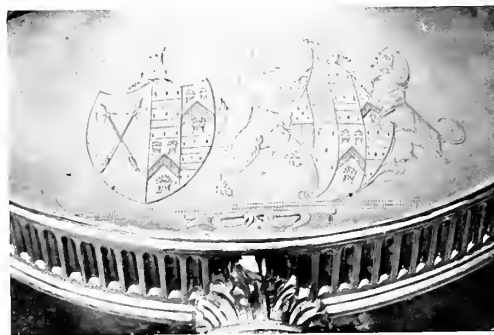

Arms lightly engraved on a tea urn by the side stroke method, by R. Morton & Co.
Date 1773. Author.

be antique silver or Old Sheffield Plate, is an act of pure vandalism, and in no instance can such alteration be carried out without seriously jeopardising the appearance and intrinsic value of the article.

The lowest deposit of silver necessary to stand the engraving of these devices was in the proportion of 12 ounces of silver to 8 lbs. of metal, and the ingenious engravers then worked by means of what came to be termed "the side stroke," i.e., the engraving tool in use was held at a very deflected angle. The specimen illustrated on previous page is a very excellent example of this kind of workmanship. Through cutting very lightly, the engraver has cleverly avoided penetrating to the copper underneath, and although the detail is not quite as clear as if cut up on a solid silver article, still it has lasted for 138 years without any necessity for re-plating.

METHOD OF SOLDERING-IN EXTRA STRONGLY PLATED METAL FOR ENGRAVING CRESTS.

The majority of teapots and coffee pots, also tea urns, about the date 1789, usually have soldered "on" silver bands for the ornamental engraving, and soldered "in" extra heavily plated shields for the crests or monograms, and it would be safe also to assign this date as an approximate one for the first introduction of separate shields for engraving in any form. This latter method of procedure was one of the cleverest features of the trade at that time, and even to-day the line where the soldering extends round the shield is almost imperceptible. A round or oval piece of the metal was cut clean out of the front of the article, then, after carefully shaping and cutting out from an extra strongly silver-plated piece of metal a shield exactly the same size, it was ingeniously hard soldered into the open space, being thus permanently affixed. After the superfluous solder had been carefully scraped from the shield it was hammered and burnished, then a small wavy line was lightly engraved around the front surface, so as to take the eye away from the almost invisible line caused by the soldering round the edges of the shield. What seems most astonishing is that these silver shields were hard soldered into the double-plated metal with apparently as little trouble as was the case with the single-sided plated metal. The latter, by being afterwards tinned at the back would of course show no traces of the soldering in, on the reverse side. When these shields are found on articles plated on both sides, it will be noticed that the subsequent flat hammering has stretched the solder out and so intermingled it with the silver surface that the lines of demarcation can only be discerned when the part so treated is held to

Ornate Shields

6 Inches	Add for Silver	Add for Silver
7 D ^o 2/2	1/6	1/6
8 D ^o 2/2	1/6	1/6
10 D ^o 2/2	1/6	1/6
12 D ^o 2/2	1/6	1/6
14 D ^o 2/2	1/6	1/6
16 D ^o 2/2	1/6	1/6
18 D ^o 2/2	1/6	1/6
20 D ^o 2/2	1/6	1/6
22 D ^o 2/2	1/6	1/6
24 D ^o 2/2	1/6	1/6
26 D ^o 2/2	1/6	1/6
30 D ^o 2/2	1/6	1/6

Round Shields

6 Inches	Add for Silver	Add for Silver
7 D ^o 2/2	1/6	1/6
8 D ^o 2/2	1/6	1/6
10 D ^o 2/2	1/6	1/6
12 D ^o 2/2	1/6	1/6
14 D ^o 2/2	1/6	1/6
16 D ^o 2/2	1/6	1/6
18 D ^o 2/2	1/6	1/6
20 D ^o 2/2	1/6	1/6
22 D ^o 2/2	1/6	1/6
24 D ^o 2/2	1/6	1/6
26 D ^o 2/2	1/6	1/6
30 D ^o 2/2	1/6	1/6

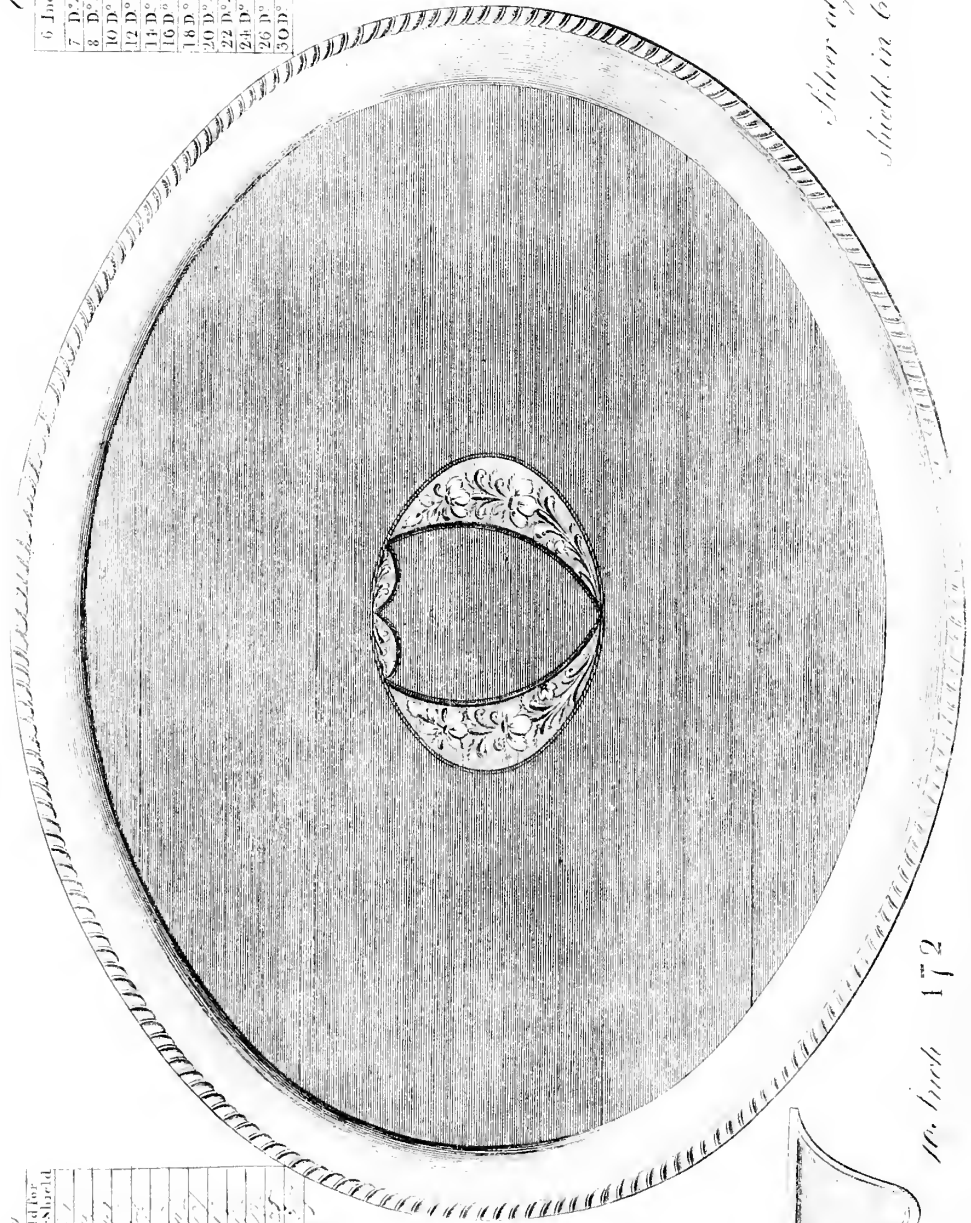

Silver edge & silver shield in Centre engraved

10 inch 172

50 each

Illustration from an old Sheffield plater's catalogue, showing the prices charged for separately soldered-in shields for engraving, about the year 1790. The property of T. Bradbury & Sons.

view with a shaded light cast upon it. The reproduction here of the centre of a teapot stand illustrative of this process, showing both the back and front views, explains itself, whilst the page reproduced from the illustrated catalogue specifies what extra charges were made for this class of workmanship about the year 1789. It is significant of the amount of labour saved by the subsequent process of rubbing in silver shields, that the later period catalogues, although mentioning silver shields (as being affixed to the various articles), do not demonstrate, as in the earlier catalogues, that any extra charge was made for the cost of their production. An instance has been found of a sugar basin with a silver engraved band—similar in style to that illustrated on teapot shown below—evidently affixed by the process described on page 93, and known as “rubbing-in or applying by heat.” For treatment of such an extended surface this method of application must, however, have been both difficult and laborious.



Front view of extra heavily plated Shield for engraving, soldered into a Salver. Date 1789.

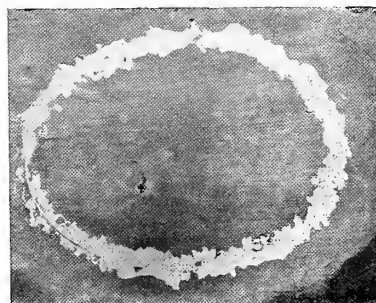

Back view of Shield, showing the solder marks, after the tin from back of Salver has been removed.

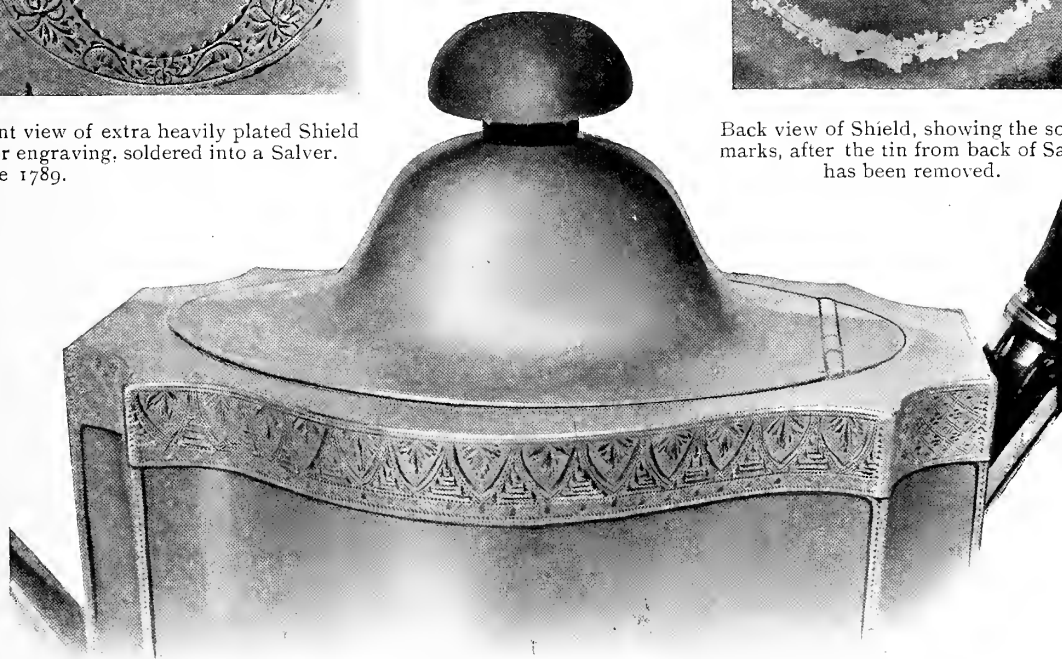

Teapot, with a silver engraved band soldered on separately for the purpose of decoration. Occasionally silver shields for engraving crests, &c., were soldered on in the same manner.

The firm of D. Holy, Wilkinson & Co., especially excelled in this method of soldering in extra strongly plated silver shields. Evidently they had

extremely skilled workmen on their premises, so perfectly are these shields let in to pieces that are still to be found bearing their well-known trade mark.*



Scallop Shell or Butter Dish, showing the solid silver hard soldered edge.

Date 1803.

Author.

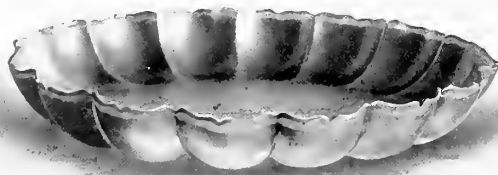

Custard or Junket Dish, showing the solid silver hard soldered edge.

Date 1795.

Mr. Hiatt Baker, Almondsbury.

The art of soldering was at this period carried almost to the scientific point. Illustrated here are two fine examples of the workman's skill. The edges around the dish and scalloped shell shown are of solid silver, hard soldered on to fused plated metal, but so cunningly is the work carried out that it is only when the articles have been allowed to become tarnished, as in this instance, that the line of demarcation between the two metals is at all discernible.† This solid silver edge is usually found to have been fixed on articles such as sauce and butter boats with lips, etc., the edges of which, by being exposed to contact with butter or grease, would, if made with soft soldered threaded edges, be difficult to clean thoroughly.

* See page 433 for further particulars of this firm, and the marks they used.

† Mr. Dudley Westropp, of Dublin, possesses a Chamber Candlestick without a mount, the edges on base of which have been treated in the same way. Other examples are also to be found bearing M. Boulton's mark.

INVENTION OF APPLYING SILVER SHIELDS BY HEAT.

The next invention in connection with the engraving of silver crests and designs was that known as the "rubbing in of a silver shield." This could be accomplished much more quickly and satisfactorily than the "letting in" process. A great deal more importance is usually attached to pieces bearing this latter form of silver shield than is their due. Apparently they were not in general use prior to the year 1810, and so far from being a guarantee of good quality, the reverse is the case. About this period the deposits of silver were becoming lighter, and thinly plated pieces of metal presented difficulties of manipulation when engravers' shields were soldered in.

The mode of rubbing in a silver shield was in its main features simple, though the invention was a most clever one, and had it not been that in those days there was a large admixture of secretiveness and jealousy amongst the rival manufacturers, no doubt more would have been recorded of Wilks, to whom the discovery has been attributed.* If he was really the originator of both the improved process of plating wire and applying silver shields, why he should never have taken out a patent for these two inventions is somewhat of a mystery. Had Samuel Roberts been able to claim the process of rubbing in silver shields as his own, undoubtedly he would have secured a patent for it, but such was not the case. As so often happens with inventions, Wilks' method, we are told, was improved upon by Roberts, but unfortunately history does not relate how, or to what extent.

Having hammered level the surface on to which the shield was to be affixed, the workman proceeded to cut out from "fine" silver usually of about 4 gauge in thickness a round or square piece suitable in size to the article on which it was to be placed. With the exception of dish covers these shields were applied to the articles before they were shaped up—the largest shields measured $4 \times 4\frac{1}{2}$ inches. Shields were not usually placed on articles of a less size than the smallest teapots, though large sugar basins and cream jugs would have them on. Having heated the shield lightly in the flame, the workman flattened it all over and then chamfered off the edges with his hammer on a stake, as thin as it was possible to get them. He now prepared the two surfaces to be joined, by rubbing them over with fine brick dust, care being exercised to remove all impurities. The shield after being placed as near as possible to the centre of the article and secured in its position by a piece of wire fastened right across the centre

* To this circumstance is due the difficulty of stating accurately the exact date of the general introduction of silver shields, applied by this method.

of the plate, was next carefully heated to a dull red or "worm" heat in the flame. The shield was at this point adhering to the surface of the plate, and the wire could therefore be removed. Immediately now the workman started to pass his burnish quickly backwards and forwards across the face of the shield, starting from the centre, without lifting it, until the whole surface of the shield had been expeditiously traversed and thereby completely laid down. It was necessary throughout this process to exercise care that no air was left in the track of the burnish, or blistering would ensue and become apparent when the article was once more subjected to the heat of the flame. In such an eventuality the whole article would have to be again subjected to a dull red heat, and the blister having been pricked, burnishing operations would again be undertaken.

After the adhesion was completed, the blank was cleaned in acid and washed off with water and subsequently hammered until the shield was entirely level with the surface of the article into which it had been burnished; in other words, the silver shield had been "forced" into the plated surface—the best description that can be given of it now would be to call it a thickening of the metal.

The blank was now ready for annealing, but the shield was once more carefully burnished over whilst still warm, and to make sure that it was quite secure and that no blisters were to be seen, the whole of the surface was finally hammered over (with a hammer the face of which was covered with a piece of carefully selected smooth cloth) on a clean, bright hammering stake.

Sufficient description has here been given to show what care had to be exercised in carrying out this very delicate little process in the manufacture of old plate, and it is not surprising to learn that a clever workman could accomplish his task in half the time required by his less competent companions; in fact one of the great tests of a man's ability was his capability in this direction. Many never succeeded at all, and it was a common term of expressing general all round incompetence to state that a workman had never been equal to the task of rubbing in a silver shield properly.

The reason why a silver shield shows so distinctly on a piece of Old Sheffield Plate when it remains uncleaned is not, as is generally supposed, that the adhesion parts round it are a guide to its presence, but that the shield had to be of pure silver, whereas the surface into which it was "rubbed" was of standard or .925 alloyed silver. If carefully examined the difference in colour between the pure silver and the standard will be noticed. It is by no means uncommon to find the shield only

slightly discoloured whilst the surface of the article appears to be very badly tarnished from exposure. But even then the standard silver with which the copper was plated tarnished only half as quickly as electro-plate of to-day, this being due to the fact that silver deposited in particles, as in the case of electro deposition, is porous and never attains the infinitely harder surface obtained by the process of rolling. After being put away for some considerable time it will be noticed that the silver shield eventually assumes a deeper tint than does the alloyed silver surface of the body of the article itself. Some people are inclined to think that the Old Sheffield Plate lacking this silver shield for engraving is of little value because the omission denotes inferior quality, but this is a mistake. Nevertheless, the presence of the shield should afford strong evidence that an article is genuine Old Sheffield Plate, and also that it was originally well made, though not necessarily extra well plated. Notwithstanding that Sheffield to-day contains workmen who can inlay silver shields successfully on plate, it would not at the present time pay the manufacturer to resort to such a method, because

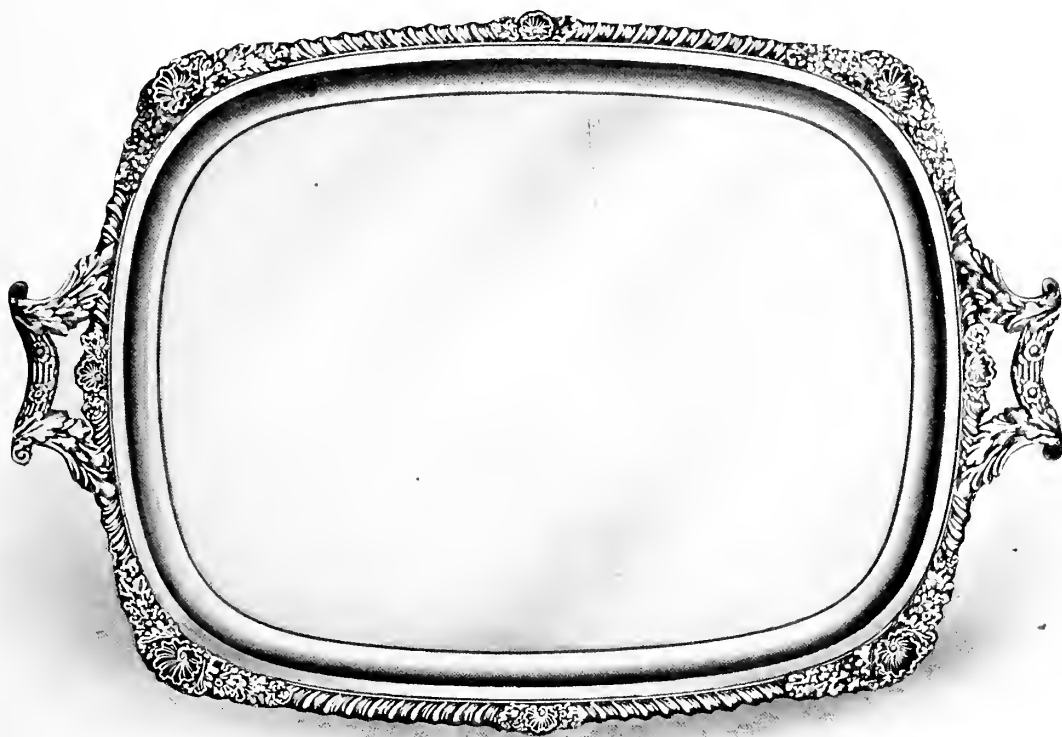

20 in. Tray, with gadroon and shell border, showing the rubbed-in silver shield,
by Gainsford & Nicholson.

Date 1815.

Holmes & Maplesden, London.

under the electro-plating system the engraving can be undertaken after the process of buffing, and the article being subsequently plated, an equal deposit of silver over its entire surface is thereby ensured.

PROCESS OF FRENCH PLATING.

The method of French plating was carried out as follows:—Having taken a thin foil of pure silver from a small packet he had at hand, the workman, first carefully scraping and cleaning the part to be manipulated, affixed the leaf after having subjected it to considerable heat—(though no heat was applied to the article itself). Then he carefully burnished the leaf down with great pressure until it adhered completely to the surface he was treating. Whilst burnishing in one leaf, he would have another being heated ready for use. By this means considerable time was saved, and the leaves were applied one over the other until the desired thickness was acquired. Several leaves could be applied simultaneously if care were exercised and the necessary heat at first attained. The method, like many others, was a simple one, the exercise of great care and celerity in the burnishing process being the objects mainly to be kept in view. As many as 50 leaves could be treated in this way, according to the will of the operator. In the cases of Sheffield Plate repairs not more than three or four would be found necessary.

French plating cannot be relied upon to last indefinitely. Its generally recognised utility was in the cases of small repairs, when by accident in the making up of an article a blemish had occurred, exposing the raw copper to view. Every workman had by him a sheaf of thin silver leaves, ready for undertaking such repairs, and had to become expert in the art of French plating. So quickly could a good workman perform this task that the old school of mechanics constantly had recourse to this method for many years after the introduction of electro-plating.* The French plating method would be a very tedious one to apply to any large copper surface, and as regards the construction of silver shields by this method it is extremely doubtful whether the thrust of the engraver's tool would not have a tendency to dislocate the various thin silver sheets of which such a surface was composed.

It is quite apparent from the illustration given on opposite page that, but for this ingenious method of restoration, many an article of plate, which otherwise must have been consigned to the scrap heap, owes its existence to-day to timely assistance from the application of the process of French plating.

* In cases where small bare patches had occurred on electro-plated articles—during the finishing process—the late works manager, Castleton, at T. Bradbury & Sons, who died in 1890, used regularly to resort to the process of French plating in preference to stripping the articles and entirely replating them, and the results were always satisfactory.

That the process of French plating was invented many years before the introduction of fused plating into general use is evidenced by notes on the subject in the French section of this work (see page 167). But the presumption that it was applicable to any thin raw surface edges such as candlestick nozzles, waiter edges, etc., etc., will not bear the light of investigation; the durability of French plating was entirely dependent on its application to parts which would not come in for an excessive amount of friction or hard wear and tear. Attention is drawn to the fused plated dollar on page 395. Had the Birmingham makers of these articles been able to rely on the process of French plating for covering up the edges, their manufacture would have been quite easy, but the difficulty was to plate the edges.



23 in. Tray, with Gadroon and Shell border. This article shows very clearly the advantages of the method of French plating. For some reason the metal has blistered, and probably the defects were not apparent until it was burnished, and being too far advanced in manufacture to discard, extensive repairs to the surface have been undertaken; these, however, are almost invisible unless the tray becomes tarnished.

(The centre silver shield has been rubbed in by the usual method.) By Matthew Boulton & Co.

Date 1812.

Lake & Son, Exeter.

PART V.

SURVIVING METHODS, WITH ILLUSTRATIONS OF WORKSHOPS,
TOOLS AND MATERIALS.*

It is unnecessary in dealing with the subject of Old Sheffield Plate to weary the reader with long descriptions of processes impossible for him to grasp in detail without a practical demonstration of the methods employed during the whole history of the industry.

The author has deemed it better therefore (as this work is intended to deal with the general subject of "Old" Sheffield Plate) to show where possible by illustrations various methods that have survived until to-day and are carried on in much the same manner as they were over a century ago. The illustrations have been taken from old workshops, tools, dies and general surroundings, especially selected as covering the period during which the industry flourished.

Detailed descriptions have previously been given where the methods of procedure are not, in some instances, quite the same as those in vogue at the present time. When and how the earliest pieces of Old Sheffield Plate came into being can only be approximately settled, mostly by drawing inferences. Half a century ago there was more material for dealing exhaustively and accurately with this question. But at that time the old platers had fallen on evil days; and who amongst them would have been bold enough to attempt to interest any one in what was then considered by the world at large a decadent industry? Therefore it came to pass that the old manufacturers, with one or two slight exceptions, did not consider the various stages of the improvements in their craft of sufficient interest to be worth recording for the benefit and instruction of succeeding generations. No doubt they would have been extremely gratified could they have realized the extent to which the artistic world has to-day learnt to appreciate the care and exactitude that they exercised in the production of their works of art.

* The author is greatly indebted to Mr. George Kinman, who has had half-a-century's varied experience of the plate trade in Sheffield, for assistance in compiling much of the detail in connection with the processes. Mr. Kinman is now manager at T. Bradbury & Son's works, where he originally served his apprenticeship.

USE OF STEEL DIES.

The use in the silversmiths' craft of dies for striking coin and other articles is very ancient, and their employment for shaping and ornamenting knife hafts was familiar to the citizens in Sheffield cutlery shops many years before Boulsover's discovery. Naturally, therefore, die stamping was at once applied to manufactures in fused plate to an extent that gave new stimulus to the art of the die sinker. The cutting of these dies out of steel before they had been hardened called for the most skilful workmanship. Like the sculptor, the die sinker used small, hardened chisels for chipping out, entirely by hand, the various details of his patterns, the two methods of procedure being almost identical except for the fact that whereas the die sinker works in steel and produces in concave form, the sculptor works in marble and stone, and his products are convex.



Front view of 8 in. Salver, made entirely by the aid of hand chasing. The general unevenness of the article will be noticed (see page 102).
Date 1760.

Author.

Reverse view of Salver.

Attention has been called to the fact that the die work of the earliest specimens of plated goods does not, in its detail, exhibit the clear and sharp definition found in the Adam and other later designs. It has been suggested that at first articles were roughly shaped up from dies and could not stand so well the hard strain of continuous stamping as those made subsequently, when great improvements had been introduced in the process of hardening and tempering cast steel.



Illustration of Dies for stamping Entrée Dishes.



Stamping for Entrée Dish, crown mount.

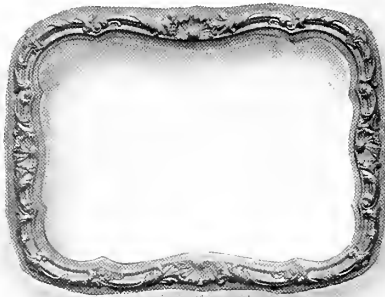

Stamping for mount, to be fixed on the lower half of dish.

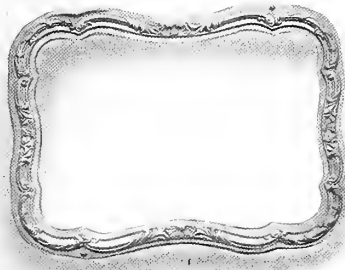

Stamping for mount to be fixed underneath the upper half or cover of Entrée dish.



Stamping for upper half or cover of Entrée Dish.

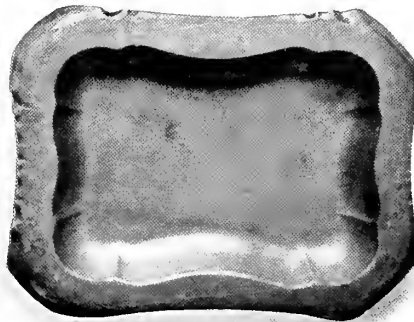

Stamping for lower half or base of Entrée Dish.

Stampings from Dies, showing the various parts used in the construction of an Entrée Dish.

If we examine carefully the earliest specimens handed down to us, it will at once be observed how few comparatively are the articles of the same design that exactly resemble each other in all their various details. This point is worthy of notice as going far to prove that it was the custom in the trade amongst the earliest manufacturers to stamp from what were known as cast metal dies, which were only sufficiently durable to produce quite a small number of articles of a particular pattern before the detail became obscured by use. Then some other style of design would be introduced in their place. It was the custom with articles struck from these

soft metal dies to subsequently chase up the various details by hand. Hence there is difficulty in differentiating exactly between an article that has been made and chased entirely by hand and one that has been produced by a combination of die stamping and hand labour. Articles such as salvers requiring deep swages and ornate borders can never be made entirely satisfactorily without the aid of dies. The illustration on page 99 of an early salver clearly demonstrates this fact, and also the failure of an attempt to make such an article entirely from one piece of metal.

Here are given illustrations of candlestick dies. Those used for the stamping out of entrée dishes and their mounts are shown on the two previous pages.



Illustrations of Dies for stamping Candlesticks.

Perhaps the most skilfully executed articles of steel workmanship ever produced in Sheffield are the delicate steel dies from which the Adam period candlesticks were struck.

A—THE STAMP SHOP.

The illustration on next page is taken from what is said to be the oldest stamp shop in Sheffield.

These shops are invariably fixed in the basements of factories, and in the illustration shown the bed of the stamps have been sunk deep into the solid rock foundation, thereby minimising the vibration caused by the stamping process until it is scarcely perceptible.

The workman in the forefront of the illustration is using a drafting punch for the purpose of drafting down small necks or "collettes," such as are required in the making up of candlesticks and branches, and also for the bases of sugar basins, etc. On his left will be observed a box of small punches for the purpose of punching up the small interstices where the "force" cannot bring out the smaller details of the die.



Drafting Punch, $8\frac{3}{4}$ in. long, 4 in. across mouth, being used by the stamper in forefront of illustration on next page.

to be seen on the extreme top of the stamp shafting. Attached to it is a thick rope, which is again fastened to a loose drop hammer with grooved sides, fitting the upright rods, to enable the stamp to slide up and down with ease when in use. To-day this wheel is kept constantly revolving by steam power.



Stampings from Dies showing the various parts used in the construction of Candlesticks.

- 1—Nozzle. 2—Pillar and Capital. 3—Foot. 4—Bizzle. 5—Nozzles.
- 6—Capitals. 7—Pillars. 8—Feet.

On the extreme end of this rope in the olden days was fastened a stirrup, into which the workman placed his foot, and thereby could bring into use the whole weight of his body for raising the heavy hammer head, and in the case of heavy stampings the services of an extra man were at times requisitioned for the purpose of raising the heaviest of these stamp heads. Before the introduction of steam power a great amount of hard work was required in order to bring up the fine outlines of mounts with their delicate variety of ornament by the aid of the stamp hammers.

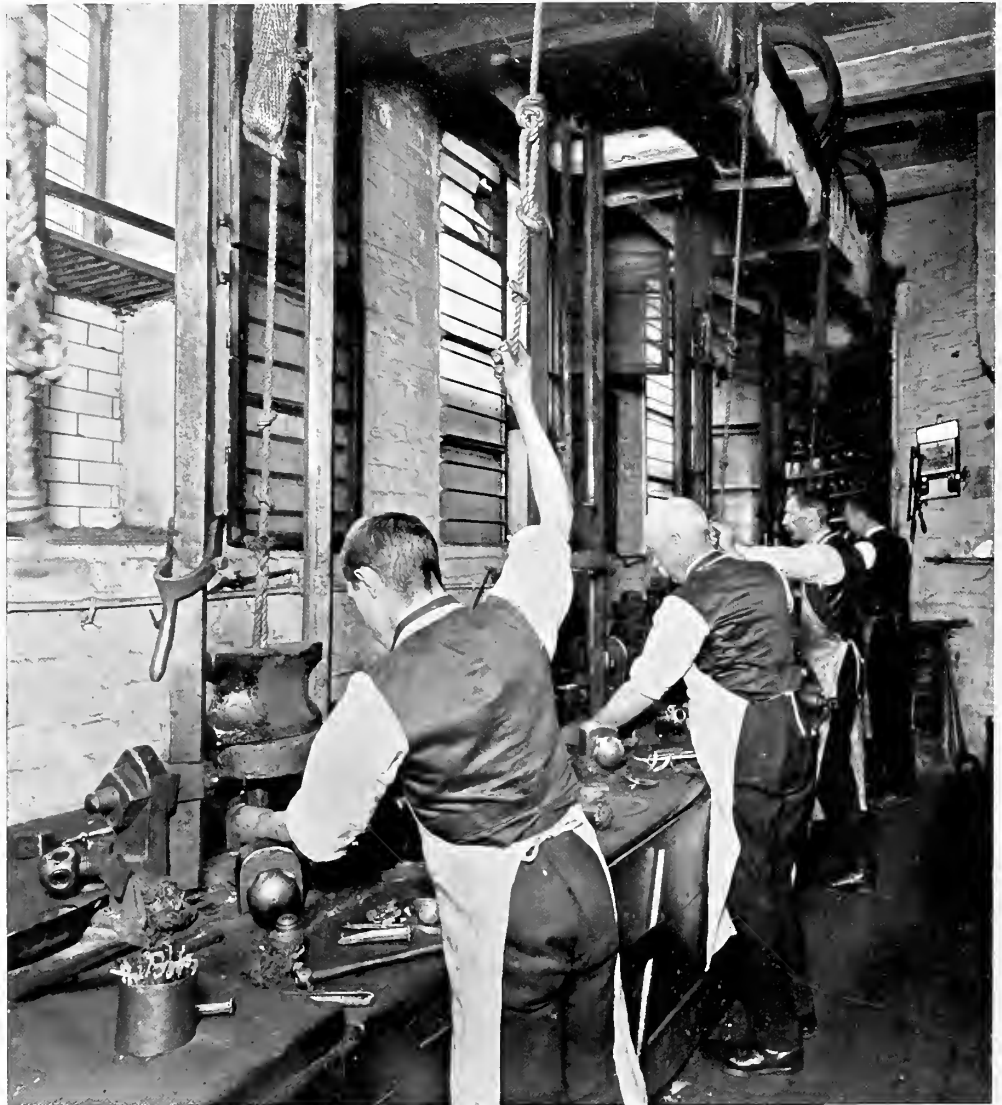

Illustration of Stamp Shop.

B—THE FIXING OF DIES.

The die was placed exactly in the centre of the stamp, midway between the upright supports. For this purpose a metal gauge was used so as to ensure that the stamp head dropped exactly in the centre of the die and so prevented any undue pressure against either side of the supports. The die was placed and kept in position by the aid of four large screws which were screwed home to the sides of the dies with the help of small wedges of various sizes called "dogs." Previous to screwing up the die to its position it was packed underneath with thick paper or cardboard. All these little matters of detail had to be carefully carried out, in order to prevent the die from springing and cracking or breaking when the stamp head was allowed to drop suddenly.

At the top and bottom of these two rods may be seen in the illustration screws which were used for the purpose of either expanding or contracting the width of the rods, so as to fit various sizes of hammer heads, either large or small. In the olden days this would be a great convenience, as with this system of adjustment it was unnecessary to have a large and varied number of different stamps in use.

In the old hammer heads—which are even now still in regular use—a square hole will be found; into this was fixed a block of wrought iron, called in the trade a "lickup." This article was toothed like a rasp, so that when the hammer head was lowered on to the face of the underneath die it picked up the molten lead after it had cooled, and after it had taken the impression of the die, into which the metal was to be stamped.

The die having now been fixed and the hammer head raised, carrying with it the lead impression of the article to be produced, a series of coppers (or linings made of copper) were placed in the die itself to prevent the metal being struck too quickly into the die when the stamp was let drop, thereby avoiding cracking the metal. The stamp head being continually raised and lowered, these coppers would be removed one by one as the article more nearly approached its ultimate shape, until at length the hollow stamping was finally struck home into the interstices of the die without any further aid from these protecting coppers.

Another purpose fulfilled by the coppers was that of preventing the tin or lead forces embedded in the stamp hammer head from leaving a portion of their substance on the stamping. Should this by any chance have

happened in the subsequent process of annealing, a hole would be burnt right through the article itself. When the hammer was not in use it was held from the die by the aid of a catch, clearly to be seen affixed to the sides of the upright support.



Illustration of Draw Bench.

THE DRAW BENCH.

The illustration shows an old "draw bench," doubtless the actual one referred to as forming part of the stock-in-trade of an old Sheffield factory, in the year 1775 (see page 64). How old this bench really is it would be difficult to state, but it has certainly been in constant use for quite 140 years.

The pieces of wire shown in the hole of the "whortle" is of the threaded or reed pattern, extensively used for making the arms of various patterns of candelabra.

Under the bench can be seen two "maundrills"; these were used for the purposes of "drawing" the various patterns and sizes of candlestick nozzles, hoops and bizzles.* On each of these maundrills will be observed two

* The nozzle is the loose pan part intended to intercept the melted wax; the hoop, the tube fixed to the pan to secure the nozzle inside the capital of candlestick; the bizzle, the inside tube part of candlestick capital into which the hoop slides.

whortles, the one for the purpose of drawing the hoops perfectly smooth and tight on to the maundrill itself, and the other for taking the hoop off when it had been drawn. The latter will be distinguished as being rather less in size, as when this was placed on the far end of the whortle it could be drawn off again by reversing it and turning it round.

The same bench was also used for drawing, i.e., lengthening and shaping up—wire to various sizes and patterns. This method was carried out as follows:—First of all, to produce a “joint wire,” i.e., a hollow wire for making teapot hinges, a piece of flat metal was cut into a narrow strip—plated on one side only—the size and thickness varying according to the size of the holes in the whortle through which it was to be drawn. The edges of the metal were then slightly bevelled inwards by the aid of a file, and one end of the strip would then be tapered towards a pencil-like point. Now having lightly hammered it up into nearly a half-round form, a small piece of round wire was fitted in and was soldered on to the end of the wire to make it solid. This thin end was then placed through the hole in the whortle which was intended to receive the wire on its being drawn. The



Section of metal previous to being drawn into joint wire.

nippers were then adjusted to this thin end, the two loops being inside the Ω -shaped loop (as is shown in the illustration). Now the gradual turning of the handle tightened up the jaws of the nippers, thereby closing up the metal into a round hollow wire. After pulling the wire the whole length of the draw bench several times, first through the larger holes of the whortle, and subsequently through the smaller ones, it eventually emerged in the form of a perfectly hollow wire, suitable for use in making joints and hinges for various articles, the centre hole always being round. All sizes and patterns of wires were invariably treated in this way.

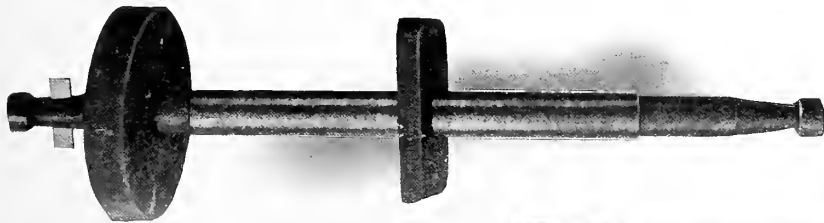

Illustration of Maundrill.



THE FOOT LATHES.

These two lathes are interesting as they are both very old, one of them being supposed to be that mentioned in the inventory list of the year 1775, as being fixed in the " candlestick garrett " and described as a " turning engine," and the oldest known in the trade. On the one to the left will be seen a pair of " clamps," used for the purpose of turning nuts and screws, small necks for candlesticks, and other little items. Fixed in that to the right may be seen a " chuck " (see page 116) used for the purpose of cutting up the tubes when making the bizzles and nozzle hoops for candlesticks. Chucks were also for turning, and sometimes for spinning the smaller parts more extensively used in the production of candelabra branches.



Illustration of Foot Lathes.

THE HAND ROLLS.

An Old Sheffield Plate factory was never complete without a pair of these rolls. Though not very extensively used latterly, they were indispensable for the purpose of reducing small pieces of metal, thereby saving the time occupied by sending the metal sheets to the rolling mills again, when small quantities of a thin gauge were required.

As previously mentioned, in the very earliest days both the fusing of the metal and subsequent hammering and rolling into sheets were carried out entirely on the premises of an Old Sheffield Plate factory. So laborious, however, was this hand-rolling process when undertaken on a large scale that one can well understand Boulsover and Hancock deciding to drop the manufacturing part of the business and turn their attention to the more lucrative work of rolling out metal sheets, (first by the aid of water and then by steam power) for the trade generally.

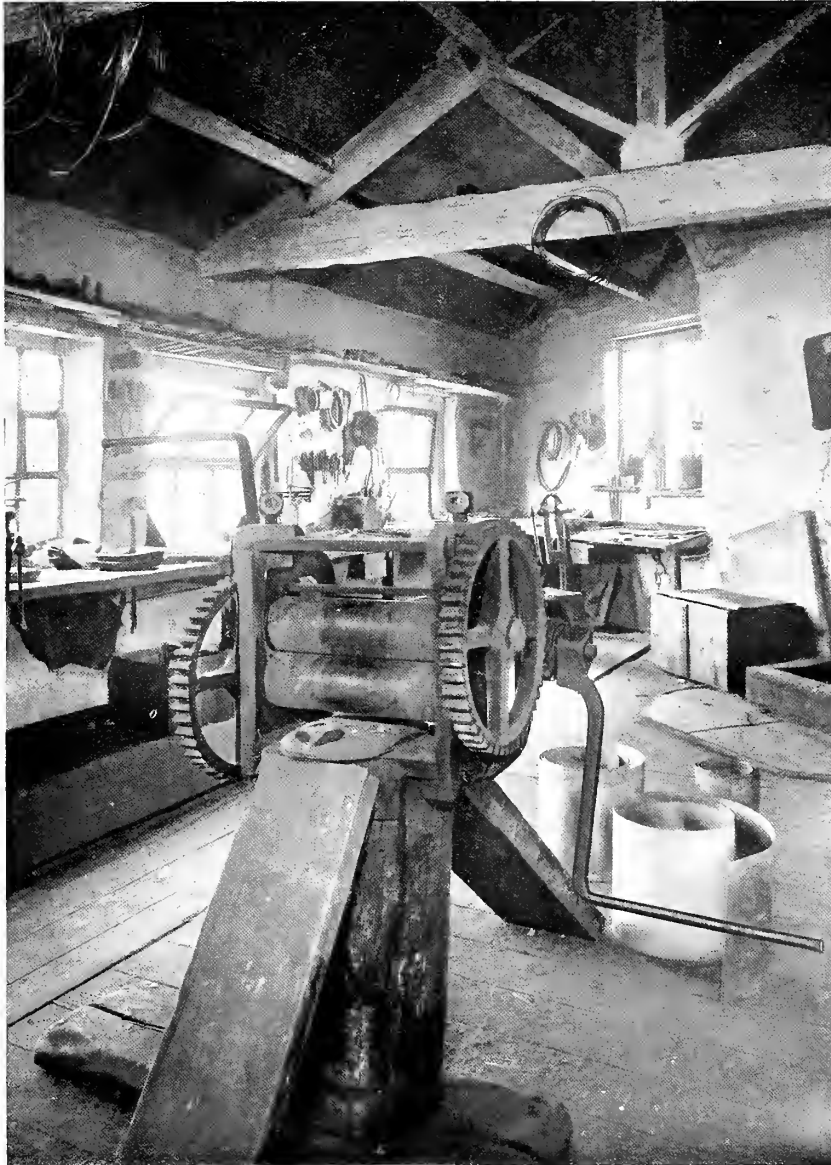

Illustration of Hand Rolls.

RAISING.

The shaping up from the flat by the aid of a mallet, known in the trade as raising, was a most important process, requiring the greatest skill on the part of the operator, and being amongst the best paid jobs that the trade had to offer to a workman.



1.—Illustration of Raising by Hand.

It is remarkable how this operation is accomplished. For instance, take a teapot, coffee pot, kettle or any other article of hollow-ware. In order to bring it into shape it is necessary to fit a stake inside the body—as shown in illustration—and then to strike up the body by the sole aid of the hammer operating on this stake. The stroke of the hammer when nearing the finishing point only leaves an impression on the article about the size of a pea. Each of these blows must be so struck that it obliterates that of its predecessor before a perfectly smooth burnishing surface can be produced. It can therefore be imagined what innumerable strokes have to be administered before the desired result is attained.

In the first illustration the workman is shown in the act of raising the body of a coffee pot. Having previously turned up a sheet of metal into a cylindrical shape, he has soldered it in a dovetail form, i.e., in order to give extra rigidity to the article during the raising process. A “cramped seam,” as this was technically called, was less liable to break than if soldered in a straight line.

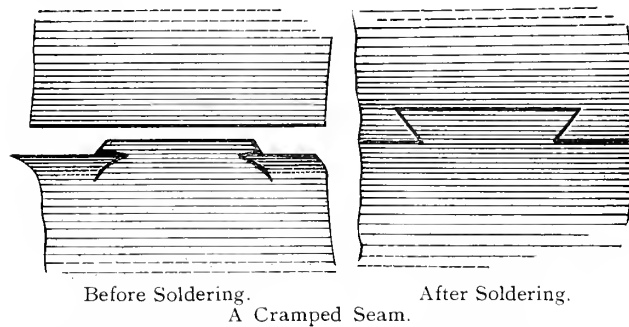

The article having been cleaned from all impurities in hot vitriol spirit, the seam is first of all hammered until the joining is almost imperceptible. After annealing it to make the body quite soft all over it is held in a vice on such a stake as is shown in the illustration. Now with a sharp-edged mallet he first of all starts to “shape in” the part which will subsequently form the neck of the coffee pot. Then, by means of a steel-faced hammer a series of hard blows is rained on the body until the required shape is evolved. Eventually all bruises are removed and a glass-like surface is produced with the assistance of this hammer.

In the second illustration the workman is raising an article from the “flat sheet,” without any help, by soldering the parts together as in the former case. This method was invariably resorted to when producing bowls and dish covers. A round sheet of metal is first of all cut out according to the size necessary for the shape required, large grooves are then struck into the sheet. The sheet is then hammered on a stake fixed in a vice—as is shown in the illustration of the raising of the coffee pot—and the body gradually hammered into the shape of a half globe by the aid of a sharp-

edged wooden mallet. At every stroke the body is taken in a little more until the exact size and shape of the article has been produced. Very large articles that would otherwise have necessitated the use of enormous dies in their production (such as dish covers, tea urns and kettle bodies, salad dishes, etc.) were made by this method of hand raising.



2 — Illustration of Raising by hand.

SWAGING.

The process of swaging is one that was associated with the manufacture of Old Sheffield Plate from the earliest times. Swages are to be found to-day in Sheffield that have been in daily use for over a century, and one swaging tool is here illustrated which there is reason to believe is the identical one referred to in the inventory list previously mentioned as in existence in the year 1775. This tool was chiefly requisitioned for the shaping up of dishes and the shaped sided dish warmers, decanter stands, tea tray, salver borders, meat and soup plate bodies, and a variety of other different parts of articles for which the manufacturer had not thought it worth while to go to the expense of cutting dies.

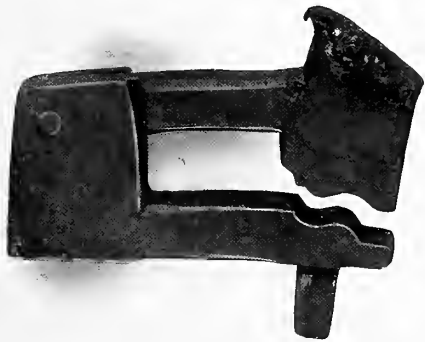

Swage, 8 in. long, over 100 years old.



Swage, 9 in. long, probably over 130 years old.

The illustrations on the two following pages explain the method employed in the use of these swages, the one guided only by the hand and the other being aided by the use of the hammer. In the first illustration, the bottom of a tray that the workman is engaged on, having been flat-hammered, a piece of leather is fastened on to the "jaw" of the swage, in order that the silver coating may run no risk of being damaged or rubbed off by the face of the swage (the underneath portion being called the face, and the movable upper part the jaw).

A piece of hard and polished copper was generally used as well as a leather for keeping the edges of the article quite smooth while being swaged, this having been first of all drafted to the shape of the swage. The method was aided—and the copper kept in position—by a "drop weight," which is clearly discernible in illustration 2, where the workman is shown swaging the border of an entrée dish. In illustration 1, the tray having been placed

in the jaws of the swage, the workman is proceeding to gently press it against his side, the border being at the same time struck with the jaw of the swage, aided by the hand ; or he might use a hammer for this purpose as in illustra-



1.—Illustration of Swaging.

tion 2, where more force is being required, a thicker piece of metal here being dealt with. When shifting the article slowly along with every stroke, great care has to be exercised not to move it too far at once, otherwise clearly

defined ridges will be seen, and thereby the appearance of the finished article spoilt. After being thoroughly swaged the tray has to be carefully flat-hammered again and then passed on to the mounters.



2.—Illustration of Swaging.

Swages may be described as bewilderingly numerous, and varying greatly both in their shape and size. The largest ever in use in Sheffield was never as much as 12 inches in length, those shown in the two illustrations being only $9\frac{1}{2}$ inches.

SPINNING.

The process of spinning must be regarded as a latter day invention in connection with Sheffield Plate. Thomas Nicholson,* writing in the year 1850, says, "Much of late years is accomplished by turning with a burnish on pieces of wood formed for the purpose, some forty years ago never contemplated. I remember being laughed at for such an attempt, but it has to-day become an important advantage in the cases of detached forms."

By this it will be seen that the old platers clung closely to their dies for the production of small detached parts, and no research has so far led to the discovery of the existence of a separate spinning shop (such as is to-day indispensable in an up-to-date Sheffield silversmith's factory) previous to the year 1820. In fact it would be pretty safe to give this as an approximate date for the introduction of spinning into the plated trade of Sheffield in any form.

A manufacturer by this method could produce a greater variety of articles, and he could also rely on the process of spinning as an alternative. Though rather more expensive a method of manufacture, it was a far quicker one, the reasons being that dies took an exceedingly long time in their execution, and a new pattern, before the invention of spinning, took as many months in its production as days would now be required by the aid of the spinner.

Perhaps the French may be credited with the invention and introduction of the process of spinning, as it is singular how they came to the front in the manufacture of fused plated ware about the years, 1820-25. It will also be noted that this date has been given as an approximate one for the invasion of our English markets by them with their cheap, lightly made and plated articles. The French accomplish this task very much more easily than it is performed in our English workshops. Their method has now reached such a scientific point that a man when at work sits on a revolving stool and practically swings on the end of the burnish, and so concentrates the full weight of his body on to the article which he is spinning; whilst the Englishman invariably stands up when performing the process, getting thereby no more force than can be exerted by the use of his arms and the weight of his head and shoulders.

As will be seen by the illustration, the workman first firmly secures the metal under treatment to the "chuck" (this being the technical term given to the pattern which has been previously turned in wood and the shape of which it is intended to impart to the article being spun) by the aid of a loose steel pin called a "centre." Then with a wooden or steel burnisher

* See page 45.

he gradually forces the metal on to the chuck, until it eventually takes the exact form of the chuck itself, fitting as closely and evenly as though it were part of it. All the time the chuck is kept revolving at a high rate of speed by the aid of machinery.



Illustration of Spinning.

This taking in of the metal has of course to be done by relays, and during the process the article has to be constantly annealed (i.e., softened, or, according to the trade term, "lighted"). This is accomplished by first of

all holding the article over a jet or flame of gas, or in the earlier days a lamp, and then putting it into a hot oven. As soon as the carbon disappears under the heat applied, then is the time to again commence operations, the metal having been brought once more to the required degree of softness.

After being burnished close up to the sides of the chuck, a blood stone burnish is used so as to get a perfectly smooth surface and so as to be sure that no unevenness or ridges, difficult of removal, are left, care being at the same time taken not to distort the shape of the article itself.

At the side of the spinning bench will be seen blood stones and burnishes, many of which have been in more or less constant service for upwards of eighty years, and are still being used every day by the spinner.

PIERCE WORKING.

The piercing of Sheffield Plate originated about the year 1765. Possibly the earliest specimens known to exist can be ante-dated some five years or so, but their manufacture was then too exceptional to bring them, as afterwards was the case, within the general range of varied productions. It will readily be understood that had the platers adopted the fretsaw process of manipulation carried out by the silversmith, the results would have been



Enlarged Section of Fused Plate, showing the result of saw piercing. The jagged edges raised by the saw are clearly discernible.

disastrous to the plated metal on which they were working. Here will be found illustrated a piece of fused plated metal that has been pierced by the fretsaw, the result being a series of jagged edges, impossible of removal without resource to filing, a proceeding that would at once have exposed the raw copper surfaces to view, and rendered the article unsightly.

An illustration is given of the process by which the early platers accomplished this object. As far as Sheffield is concerned, it has never been superseded for this class of work, and is to-day still being carried on.

The fly-punching and piercing machine was worked in the following manner. A small tool, carefully hardened at the end, selected for the pattern requiring to be pierced, was fixed into the head of the machine and firmly wedged into its position by the aid of screws. The bed into which this upper or striking face of the small "chisel" would fit was also firmly wedged to the large underneath C-shaped arm—shown in the picture—until it came exactly under the face of the cutting-out tool. This little arrangement resembled on a small scale the fixing of the stamp hammer and the underneath die in the process of stamping up articles from dies.

The article itself—in this instance the base of a soy frame—which has had the various spaces to be pierced out on its edge carefully delineated by the workman, was fixed at a sufficiently correct angle to prevent its being forced out of position under the pressure of the punch. Underneath will be seen a tiny bucket, into which the small scraps punched out by this process would fall.

It will be readily understood from the illustration that by pulling the lever towards him or away from him, the workman could at will press down into its bed or raise the punch by the consequent lifting or lowering of the screw (to be seen in the upper part of the machine). The force of the blow would be very great on account of the

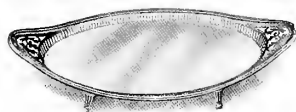
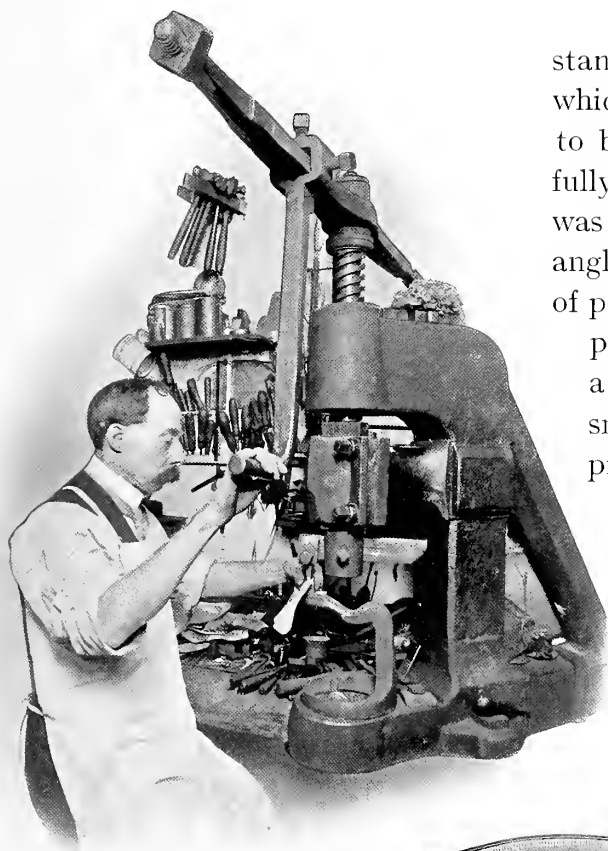

Illustration of Punching and Piercing Machine, with soy frame base after piercing.

tremendous impetus given to the screw by the weights on the cross arms or lever here shown, and the large bundle of cotton waste to be seen towards the far end of the arm was usually affixed to prevent the infliction of a damaging blow to any passing workman during the time the machine was being used.



Illustrations of Beds and Punches used in the Piercing Machine.

Illustrated here are a series of beds and punches in use for this piercing-out machine. They show how ingenious was the method by which this work was accomplished.

A section of an Old Sheffield plated pierced fish slice is shown here, made between the years 1775-1785. A careful examination will show the great advantages derived from this method of fly-piercing the Old Sheffield Plate. The gradual squeezing out of the metal under the piercing tool has had the effect of dragging down with it the surface of the silver, and so at the same time covering up the raw edges of the copper that otherwise with the process of saw piercing must have become exposed. On the underneath side of the piercing, the bedding tool, having been securely screwed up to the pattern, has prevented the edges of the lower side from being forced out of shape. This same machine was

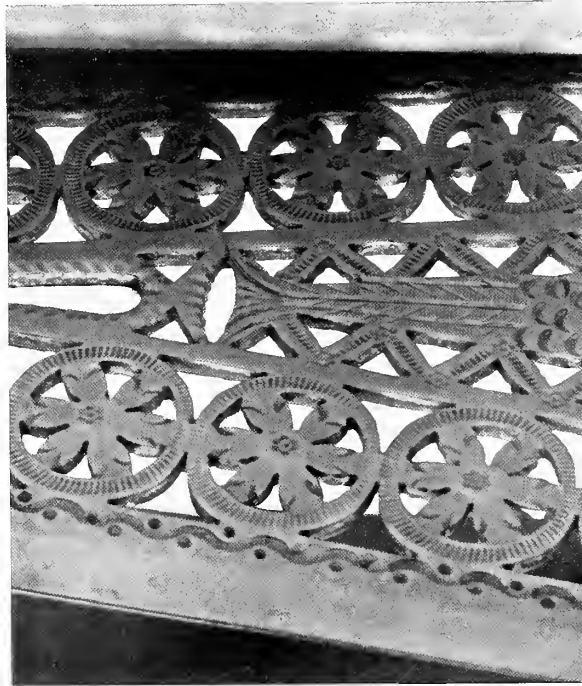

Enlarged Section of pierced Fish Slice, showing how the silver has been borne down inside the edges of the piercing by the pressure of the cutting-out tool.

Date 1775—1785.

Mr. Dudley Westropp, Dublin.

also used for pressing various patterns on to the borders of the articles both before and after they had been pierced, and by substituting various punches bearing different devices, the variations of the patterns could be alternated at the will of the manipulator.

SOLDERING AND MOUNTING.

The illustration demonstrates how this process has been carried out in Sheffield factories since the introduction of gas, now some 90 odd years or so ago. To this day the shop in which the workmen in Sheffield do their soldering is described as the lamp shop, a relic of the times when the men used oil lamps and a blow pipe for the purposes of soldering.

An interesting little advertisement by Messrs. Green & Pickslay is here inserted as giving the date when the Sheffield manufacturers finally abandoned

GAS LIGHT.

GREEN & PICKSLAY most respectfully inform their Friends and the Public, that in addition to their present establishments, they have engaged a Person of experience that has long been under the direction of Mr. Gasrow, the Company's Engineer, expressly for the purpose of fixing the Gas Pipes and Lamps in the Shops and Warehouses, and having already prepared their own Premises for Inspection, beg to offer their services as fitters up, assuring those who may favor them with their Orders, that every attention shall be paid to complete the work in the best possible manner, and on the most reasonable terms.

G & P beg also to state that they have the choice of a most extensive assortment of Lamps, Burners, &c. obtained exclusively by the Gas Company for the accommodation of their Customers, and as the Company expect shortly to be prepared to give the Gas, G & P. hope to be favored with the early commands from their Friends.

Sheffield June 7th 1819

the old oil lamps in favour of gas for soldering purposes. It is recorded that on the introduction of gas generally into Sheffield, for the first few nights a large number of the inhabitants decamped to the outskirts of the town, fearing that the town ran great risks of being completely destroyed by explosion.

There are two methods of soldering; the one more commonly in use in the olden days amongst the Sheffield platers was that known as soft soldering, not requiring such great heat in its application as hard soldering.

Now soft solder contained a great quantity of lead, the other ingredient being tin, but the proportions of these metals varied considerably and were regulated by the amount of heat that the article being fashioned could stand. For instance, a lighter and more delicate admixture would be used when securing the thin silver mounts to a salver or candlestick of the gadroon and shell pattern than would be necessary for the much greater heat required when soldering a heavy filled mount on to a tray, as in the illustration.

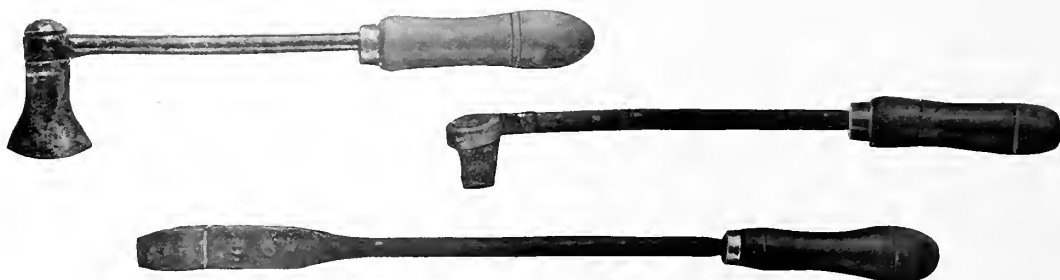

Three varieties of Soldering Irons, usually employed when making Old Sheffield Plate,

The workman on opposite page is shown soldering on a mount—such as is described under the heading “introduction of silver edges,” on page 82—to a tray which has been hammered and swaged, as illustrated on page 136. Having first cut out and filed the plate to the pattern of the mount, (this being rather less in size than the tray on which it is to be soldered), he carefully tins the edges with a soldering iron, then he takes the silver threaded edge (which has previously been drawn through a whortle) and carefully solders this on to the underneath edge of the tray. He has previously shaped

it up so as to closely follow the indentations of the mount. He then temporarily fastens or cramps the whole together with small sections of bent-up wire (see illustration), and proceeds to apply the blow pipe all round the tray. Before finally soldering the mount on to the tray, he has covered the parts to be subjected to the flame with whitening, so as to prevent discolouration by over-heating, and also to prevent the solder from running on to the plate (the edges of the mount having been plied with resin to act as a flux).



Illustration of Soldering.

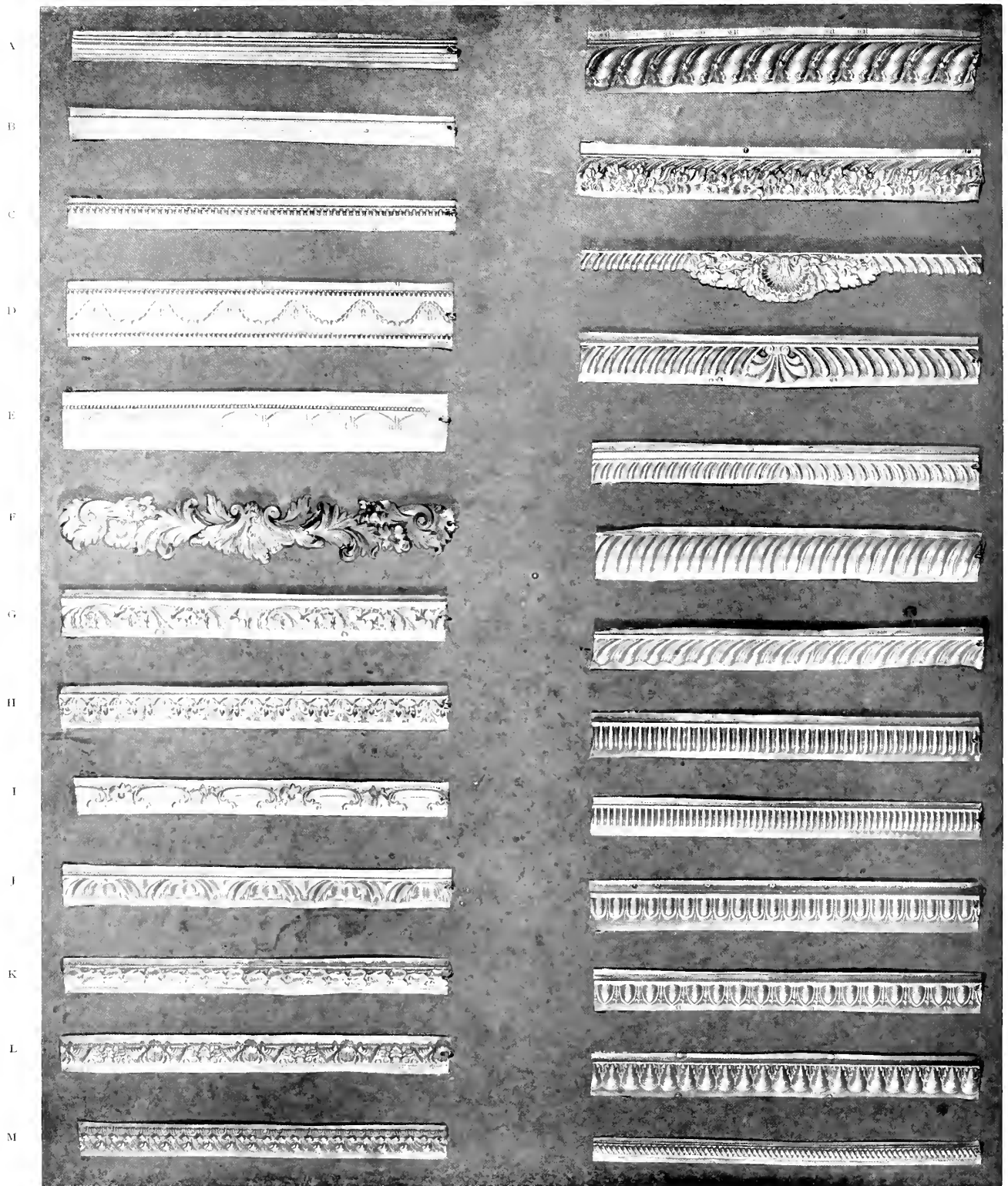

A varied Selection of Mounts from Dies used in the manufacture of Old Sheffield Plate.

A.—Thread. B.—Fine Thread. C.—French Gadroon. D.—Festoon and Bead. E.—Festoon and Tassel. F.—Scroll Leaf and Flowers. G.—Leaf and Scroll. H.—Acanthus. I.—Scroll and Flower. J.—Crescent Leaf. K.—Laurel Leaf. L.—Cornucopia. M.—Double Leaf. N.—Leaf and Gadroon. O.—Gadroon with Flowers. P.—Oak Shell and Gadroon. Q.—Gadroon and Shell. R.—Gadroon with Centre. S.—Slant Gadroon. T.—Slant Gadroon. U.—Straight Gadroon. V.—Fine Straight Gadroon. W.—Shield and Dart. X.—Lgg and Dart. Y.—Leaf and Shell. Z.—Rope or Twist.

The heat of the blow pipe causes the solder to melt, and by so doing the border becomes hermetically sealed to the mount of the tray. The tray has, after soldering and removal of the cramps, to be cleaned with pearl ash, so as to take away the impurities set up by the soldering process.

Another method of soldering on mounts or borders was accomplished in the following manner: Having filed the edge of the tray all round as described above until it was just a little less in size than the whole mount when completed, he then cramped the mount on and soldered it down, care being taken that this silver-filled mount sank below the border until it completely covered the exposed copper edge of the tray. To accomplish this the workman fastened a cork to the end of his tongs, in order to squeeze down the mount when the solder had become sufficiently heated. It was the custom during this operation to have in use a thin copper covering mount to protect the silver mount, in order to prevent the latter from becoming crushed and bruised by the pressure which it was necessary to exert when forcing it down. After the soldering was completed and the tray carefully cleaned, the edges of the mount were burnished and carefully lapped over the outer edge of the tray plate. Old steel dies for various patterns of mounts are still to be numbered by the score at the author's factory, but comparatively few are now in regular use. A variety of these are illustrated on previous page.

Hard solder is a compound consisting chiefly of silver and brass. Hard soldering was carried out in exactly the same way as soft soldering, but was not greatly in use amongst the Sheffield platers, excepting when making solid silver goods. The lasting properties of an article treated by this method were very much greater than that of one that had been soft soldered, but it could not very generally be applied to Sheffield plated articles on account of the risk of completely melting the thin silver mounts and threaded edges by the excessive heat required to melt this solder. In the earlier days of the industry and before the introduction of silver threaded edges and mounts, hard soldering was more frequently resorted to. Some of the candlestick makers previous to the year 1785 fastened the parts together entirely with the aid of hard solder.

An illustration is given on following page of a somewhat unusual method of treatment in the making and strengthening of round silver borders. This specimen is interesting as being rather scarce, and attention is also called to a similar mode of mounting carried out on the border of a dish-ring,



6½ in. Pierced Border Salver. The border wrapped round a piece of wire for strengthening purposes.
Date 1765—1775. Author.



Reverse side of Pierced Border Salver, showing back of mount wrapped round the wire.

illustrated at foot of page 279. It has been presumed that this ring was made in Ireland, owing to this departure from orthodox methods in its manufacture. Such, however, was not of necessity the case.

The waiter, as also the dish ring, has had an outer edge lapped over a piece of iron wire to give it strength in use, its manipulation being far more simple than any of the other methods adopted for mounting purposes elsewhere described in detail. The metal employed in these cases was usually of an extra strength, but articles made in this way cannot be said to be so satisfactory in use on account of their liability to accumulate dirt underneath the mounts. Therefore, though presenting fewer difficulties in the process of manufacture, the method never came into very general use.

FLAT HAMMERING.

The most important part in the manufacturing process of Old Plate was doubtless the flat hammering. No article would be made without the aid of the hammer in one form or another. The ultimate object to be attained by the hammering was to impart a correct shape and also a quite smooth and mirror-like surface to everything under construction.

This hammering of articles in the days of Old Sheffield Plate was a more serious business even than it is to-day. The difficulty was to obtain a perfectly smooth surface where the engraver's shield had previously been

rubbed in. The metal all around this silver shield was bulged and stretched by the heat and by the subsequent hammering to which it had been subjected. All these unevennesses had to be removed by the aid of the "flat hammer."



Illustration of Flat Hammering.

The "flat" hammer is shown in the picture of the process of flat-hammering. It is a most important tool, weighing about 4 lbs., the face of which is usually about $2\frac{1}{2}$ inches in diameter, and although of such large

size, on account of the slight doming towards its centre, the hardest stroke only leaves an impression on the tray about the size of a shilling piece. And here again every stroke has to die away into the last in order eventually to obtain the required dead smooth surface. The stakes in use are all of bright polished steel, and if properly flat-hammered the tray when finished should only now require to be subjected to the process of burnishing and hand polishing. The flat hammering has the result of making the tray absolutely rigid and firm.



Hammering Stake 2 ft. 3 in. high, in use for over 100 years. On the wooden base will be noticed marks caused by countless numbers of small nails that have from time to time been driven in for fastening down a leather sheet to intercept any dust that might arise

The hammering stakes were preserved by being cleaned and polished with almost as much care as a surgeon would exercise in the preservation of his instruments. And in order to prevent infinitesimal particles of dust arising from the base of the stake itself when in use, a leather covering was fastened around the pillar and nailed down to the wooden bed into which it was fixed. It was no uncommon practice for apprentice lads to sit close up to the stake when an important piece of flat hammering was being undertaken, and as each successive blow was struck by the hammer man, these lads would blow across the face of the stake to ensure that no particle of grit or dust had arisen and settled on the top of the stake or article being hammered, between the strokes. With such great care exercised in their preservation therefore, it is not surprising

to find that there are many hammering stakes still in constant use to-day in Sheffield that have seen considerably more than 100 years of regular daily service.

Hammering stakes are flat on the outer edges, rising gradually towards an almost imperceptible dome in the centre of the stake. Neither is the hammer head itself quite flat, being just a shade full towards its centre. By this system of combination between the hammer heads and stakes it will

be easily realised what care is taken that the blows given leave no trace of an outer or cutting edge, as would naturally be the case were both the stake and hammer head itself completely level.

London silversmiths have a different method of hammering, and also a different kind of hammer ; the latter being about 6 inches long and having a much smaller face than those used by the Sheffield manufacturers.

The old plated trays and those made to-day in Sheffield are hammered from the back as shown in illustration ; whereas the London silversmiths usually hammered from the front of the trays and waiters.

TINNING.

The very necessary process of tinning was most extensively used in the manufacture of Old Sheffield Plated goods. One might describe tin as an indispensable agent of the old plated trade, so extensively were its services called into requisition throughout the whole period during which the process of plating by fusion was in being.

We find that as early as the 15th century apostle and other patterns of spoons were made of latten or brass, and subsequently tinned, so that coming in contact with food no serious consequences would be entailed. As a component part in the making of solder it must have been in requisition for many centuries previous to this period.

The method of tinning goods in use by the Sheffield Plate manufacturers was a simple one, but the greatest care had to be exercised in removing every particle of dirt before commencing operations. These were carried out as follows : After the cleaning process had been thoroughly undertaken—in the cases of teapots, coffee pots, tea urns or any other vessels that had shaped bodies—the outside of the article had to be well covered with glue and whitening so as to prevent the tin from damaging the plated parts if by chance it should overflow on to the body of the article itself when being applied. It was then held over a pit or ladle of molten tin, having first been sprinkled all over with sal-ammoniac and well heated. The tin was then poured inside the vessel until the whole of the copper surface was completely covered, and resembled, by its brilliance, pure silver. Waiters, trays and articles with a smooth flat surface were treated in a similar manner, but in order to obtain a dead smooth surface, the article was gently heated in a flame, and whilst it was hot a piece of soft linen was used for the purpose of wiping off the tin. This produced the desired effect.

In all cases of single side plating, the underneath parts and insides of articles were always most carefully coated with tin.



Illustration of Burnishing.

BURNISHING.

The method of obtaining a bright surface, known as burnishing, was—and still is—invariably performed by women, being the last process undertaken in the production of any article previous to its being finally overhauled, hand polished, and turned out ready for use. Before commencing proceedings the article is scrubbed all over with a damp, clean, white linen rag dipped in white Calais sand; then, after well scouring the plainer parts and brushing



Illustrations of Burnishing Tools, showing the leather strop on which the burnish is constantly rubbed during the process. The marks on the handles are made by the various owners of the articles.

the more ornate with a hair brush, also dipped in Calais sand, it is washed all over in clean water. This operation is necessary in order to remove any grease or other substance which would be likely to remain in the path of the burnish, thereby preventing it from getting a grip on the surface.

The illustration shows a small vessel called a "sud pot,"* into which the woman constantly dips the end of her burnish in order to prevent it from "dragging" the silver. A leather strop will also be seen in the illustration, used for the purpose of keeping the burnish constantly smooth and bright during the process. On this leather strop is sprinkled a little of what is known as "burnishing putty." The burnish is first drawn rapidly across the face of the article backwards and forwards, great pressure at the same time being exerted. This method is called "steeling." Then recourse is had to the use of the "blue" or "blood" stone. With the aid of this instrument a blacker or better colour can be produced, and any mark left by the steel burnish removed. After being completely burnished all over—care being taken that the burnish has sought out all the dull parts inside the interstices of the mounts—the article is polished by hand with a little wet rouge. This has the effect of taking out any marks left in the track of the burnish and thereby also imparting a more brilliant mirror-like finish when completed.

There is little doubt that the process of burnishing was in use in the very earliest days of Sheffield plate manufacture, probably by the aid of the tools now in use, as from the inventory list published in this book, as early as the year 1775, a separate burnishing room with its "appurtenances" is mentioned. This includes "blood stone and steel burnishers," etc. (See page 63).

* The sud pot contains a mixture of soap and water.

PART VI.

INNOVATIONS THAT REVOLUTIONIZED THE OLD TRADE.

LAST STAGES OF THE MANUFACTURE OF FUSED PLATE, AND A DESCRIPTION
BY AN OLD WORKMAN.

The method of manufacturing fused plated wares died out gradually; in one or two isolated instances it was perpetuated as a trade and intermingled with the process of electro-plating until the year 1855, all records ceasing after that year. Between the years 1830—1840 (the transitional period) German silver began to supersede copper as a foundation metal for fused plating purposes. The apprentices were, until the year 1850, instructed thoroughly in all the methods associated with the older process of manufacturing articles from fused plated copper. The various firms, about the year 1845, seem to have been equally divided between those who used German silver as a foundation metal and those who still worked in copper. It will be easily realised, too, that the workmen would much prefer—as long as they possibly could—to retain the use of a metal in which they had been educated and instructed, and to which, by the force of habit, they had grown accustomed. Consequently early specimens of the transitional period are scarce.

There are one or two old workmen still surviving who for some years after the expiration of their apprenticeship never attempted to work up German silver at all; one of these, F. T. Burdekin, now in his 87th year—formerly employed by Walker, Knowles & Co.—has furnished the following account of how the process was carried out for the manufacture of salvers, entrée dishes, and many and various other kinds of heavier plated goods as recently as 60 to 70 years ago. Burdekin's description is the more interesting as showing how little the modern system of the sub-division of labour was in vogue at that time.

“ It was highly necessary for those who worked up the plate to observe the strictest cleanliness. A workman would keep his bench scrupulously clean, and before commencing operations had the floor of the shop swept and sprinkled with water in order to keep down the dust, as it was necessary to avoid everything in the shape of dust or dirt during the process of manufacture.

“ In order to illustrate the method of making Old Sheffield Plate, I propose to take a 12” salver through the various processes, from the ‘ blank ’ stage to the finished article as it was done in my early days.

“ These processes called for the most skilful workmen, who had to work with polished steel flat hammers ranging from four ounces to six and a half pounds in weight, and were commonly known as flat hammerers and large braziers. In those days it was customary for one

man to both hammer and mount the goods, making them throughout from the blank to the burnishing and polishing point, this latter part of the workmanship being executed by the female staff.

“The workman started with a rolled blank of silver-plated copper, cut out of the sheet to form a round plate from $\frac{1}{32}$ to $\frac{1}{16}$ of an inch thick. He then most carefully hammered it all over until it was quite flat, being now ready to have the silver shield put in the centre. This latter was first of all cut out of a piece of fine silver to the required dimensions and then hammered very thin round the edges: the blank was now taken to a charcoal fire and heated to a dull-red heat. The shield, after being cleaned in acid and water and thoroughly dried, was placed in the middle of the plate and also heated to the required temperature, and then rubbed hard with a steel burnish until it adhered firmly to the plate, great care being taken that the shield did not move from the desired position, and also that no air or impurities remained between the shield and plate, or blistering would ensue.

“After the adhesion was completed the blank was cleaned in acid and water, and then carefully hammered until the shield was quite level with the surface of the plate; it was now ready for annealing, the shield being burnished again whilst still hot to show that it was quite secure and no blisters were apparent. Cleaning once again, it was then hammered finally all over on a bright steel stake. Now it was put on the lathe to have the edges turned down preparatory to the stamping process, which would bring up the edges or ‘swage’ on which the stamped filled silver mounts were to be soldered (or spun on the lathe if for quite a plain mount). These mounts having been stamped in thin silver, were whitened on the front and filled with a mixture of tin and lead. They were then filed on the back until the edge or flash of mount dropped off. After this had been accomplished they were fitted to the edge of blank, and cut and filed until they assumed the shape required. Now they were slightly reduced in size to allow room for the silver edge, which was then finally soldered on. This was done after the waiver had been filed and thinned down to a feather edge to allow of the fastening on of this silver thread. Should the mount be a shaped one (as in the case of the shell pattern salver illustrated), the thread was put on the edge with a small tool called a thread fork, to press it into all the corners of the indenting, and then carefully soldered on.

“The plate being then ready for the mounts to be permanently fastened on, these latter were taken off again and covered with a mixture of glue and whitening to prevent the solder sticking to the outside; the mount being truly fixed on again, was held in its place with small iron cramps. The waiver was then taken to the hearth and heated slowly until the mounts became permanently fixed on to the swage of the plate.

“The little bits of solder were then brushed or wiped off whilst hot. Being now ready for the feet to be soldered on, the latter having previously been treated in exactly a similar fashion to the thin silver mounts, i.e., filled up with a mixture of lead and tin, were carefully soldered on to the underneath part of the plate. After boiling in pearlsh to remove the grease, resin, etc., the edge of the mount was then burnished to the thread edge, the work was now completed and ready for the burnishing. This latter operation was performed by women, and it consisted of passing quickly backwards and forwards a hard, smooth, steel burnish across the face of waiver and into the edges of the mounts, until the whole resembled a looking glass. With a few final touchings up with rouge and hand polishing, being subsequently washed, the salver was ready for use.

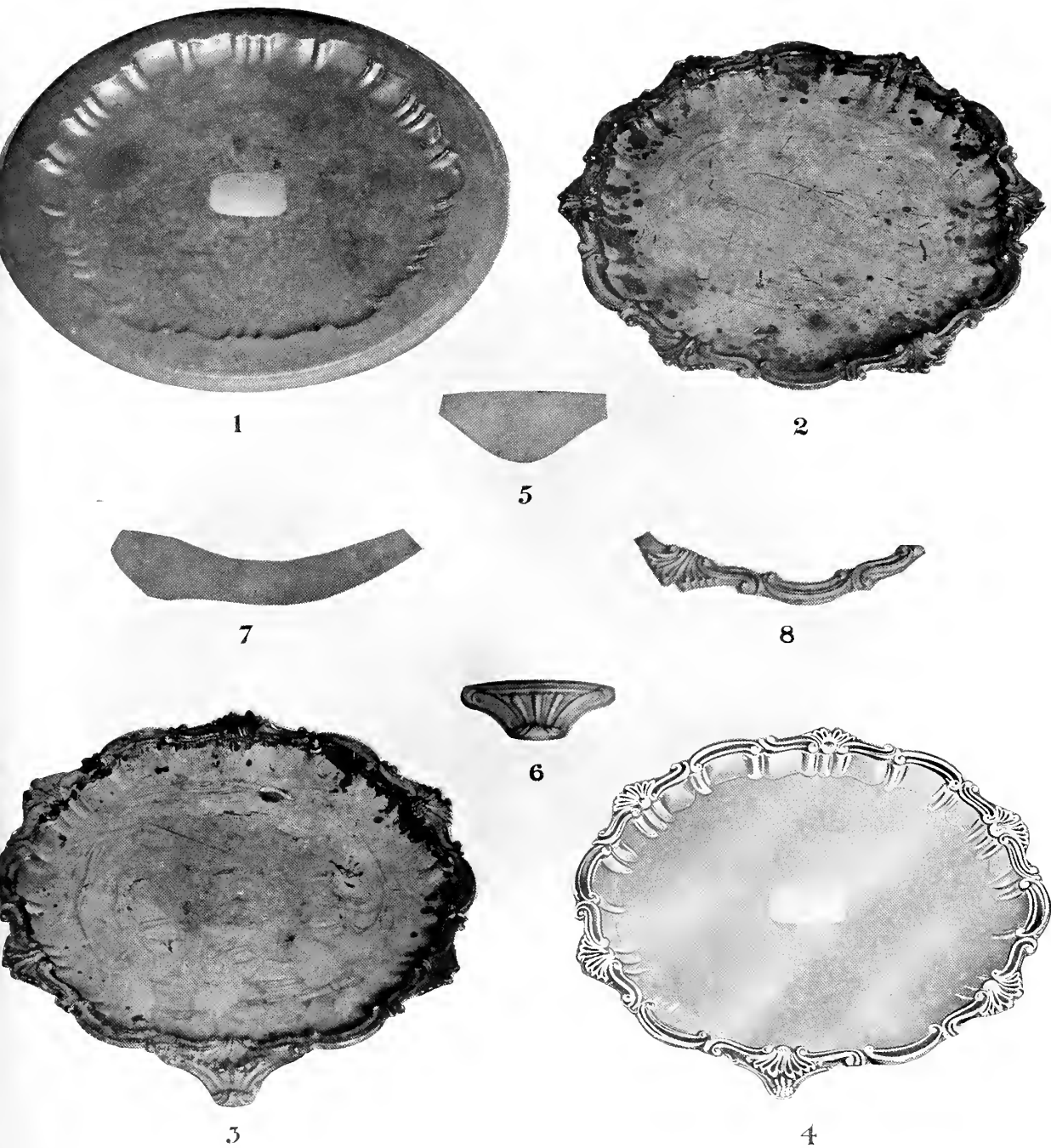

Illustration showing the various stages of manufacture when making a fused plated salver by the old process.

1—8 in. Salver, blank stamped up from fused plate after the silver shield has been rubbed in. 2—The waiter plate after the process of soldering on the mounts has been undertaken. 3—After the feet have been soldered on. 4—8 in. shell pattern Salver, after being in service for close on a century. 5 and 7—Thin silver strips cut out preparatory to stamping (5 for foot; 7 for mount). 6 and 8—The same sections after being stamped and filled with lead and tin, preparatory to their being soldered on to the Salver.

“The stampings from Old Sheffield dies for large, plain, florid gadroon tray here shewn, would be carried through all the same processes of manufacture. a space being left at either end of the plate after fitting the mounts on to the swage for soldering on the handles, these handles being made of thin stamped silver, and treated in every respect similarly to the mounts.”



24 in. Tray Plate after being stamped and swaged, also showing various sections of silver mounts for handles, feet and borders as they have left the dies. Section of florid mount on top shows the mount filled and filed preparatory to soldering it to the border of Tray.

The salver (No. 4) illustrated on previous page, was made some century ago, and has been in more or less continuous use ever since, having a silver rubbed-in shield and silver threaded edges. Beside it, No. 3, is a duplicate salver, recently made from the same dies, and carried through all the different processes of the old rolled plate up to the finishing point; it is plated on both sides, has silver-filled mounts, silver-threaded edges, and rubbed-in silver shield. The making of this article should definitely settle the question of the possibility of the exact reproduction of Old Sheffield Plate, and any

supposition that the art was an entirely lost one may therefore be dispelled. In the case of the largest proportion of the articles made under the old process, it would take many years of arduous labour and skilled training of workmen and apprentices before anything like such a degree of proficiency could be attained as was formerly the case. But the collector need not greatly fear meeting with such reproductions. In the first place the cost entailed in reproducing the new waiter almost equalled that of an article of the same weight in sterling silver. Secondly and most important of all it lacks the mellow appearance of age and wear which is the surest test of antiquity and is quite incapable of reproduction so exact as to deceive an expert collector, let the vendor try how he will.

By this it will be seen that the making of larger articles of Old Sheffield Plate by the old process has never sunk "entirely" into disuse, as the public might otherwise have readily supposed.

INTRODUCTION OF GERMAN SILVER.

"German silver," consisting of nickel, copper and zinc in various proportions, has since about the year 1845 been universally adopted as the basis for the best plated goods, it being found to be in every way a stronger and more durable metal than copper, though produced at a greater expense. It seems that the name German silver was derived from the fact that in the year 1830 a Mr. Guitike, from Berlin, came over to Sheffield with the first sample of this new compound metal, a specimen of a similar kind having found its way to Vienna, where a chemist had spent a great deal of time in trying to discover its component parts. The metal had come originally from China, where its composition had been known to the Chinese almost from time immemorial. (Articles were discovered at the taking of the Cape in 1795, made from this or from a somewhat similar material imported from the East.) Samuel Roberts was the first person to avail himself of this metal, in 1830, taking out a patent for plating German silver on to copper, and then fusing a silver layer on the top of the two lower metals. This process lessened the quantity of silver required without impairing durability. Guitike's metal was, however, at first too brittle to come into very general use, and it seems that not until some years later did copper begin to be gradually supplanted by variations of the new compound, some manufacturers describing it as patent "Argentine," under which designation a few wholesale houses advertised their wares as late as the year 1850.

In 1836, a Birmingham metal manufacturer named Merry took out a patent for plating silver by the process of fusion on to German silver, but to his surprise when he came to Sheffield to solicit orders for this new compound metal, he found his idea anticipated. He was shown that his method had been previously invented and tested by Thomas Nicholson, who was then in partnership with Robert Gainsford. This therefore invalidated his patent, and from that time the process was thrown open to the trade, who adopted it with avidity, it eventually superseded all others until the introduction of the process of electro-plating. A few years later great improvements in the colour of the metal were introduced, and from about 1845 down to the present day in this country little else has been used as a foundation for serviceable household plated table requirements than what has come to be known as "German silver."

The best quality of German silver for plating to-day consists of an admixture of the following ingredients :—

Copper 65%, Spelter 20%, Nickel 15%,

which brings the cost, taking the copper at an average price of £65 per ton, to rather more than 10% in excess of the alloyed copper material that was used in former times.

EXPERT OPINION ON THE COMPARISON TO BE DRAWN BETWEEN GERMAN
SILVER AND COPPER AS A FOUNDATION METAL.

The greatest authority we possess on the subject of mixture of metals in connection with the plating trade to-day is undoubtedly Mr. Alfred S. Johnstone, a director of the firm of Messrs. Henry Wiggin & Co., who has kindly furnished the following notes explanatory of the question why German silver supplanted copper as a foundation metal for the purposes of plating. The particulars are most interesting; Mr. Johnstone gives us not only corroborative evidence as to the exact date of the almost total supplanting of the older metal by German silver for the purpose of plating, but also the definite date when the process of plating by fusion was practically abandoned, i.e., 1850 :—

"I am afraid my memory does not date back far enough to enable me to give any practical account of the immediate change from fused-plating to that of electro-plating in the production of articles for household use. Though gradual in one sense, the change was very complete, and when I started work in 1850 the rolling of silver on to copper and copper alloys had given place to the process of electro-plating. German silver had appeared as a

temporary white alloy, which on the removal by wear, etc., of the silver coating left the defects less noticeable than was the case with copper; but beyond this the process of electric and galvanic plating had become so far perfected that the method was simple and the result effective at very small expense, as a much thinner coating of silver could be applied than in the case of fused plating. There were also other great advantages, viz., that the most complicated ornamentation could now be as easily coated with silver as a smooth and even surface, therefore rendering the workmanship less costly.

As regards the liability to oxidation and consequently the injurious character of copper and its alloys, copper would be really by far the least objectionable metal of the two. It will be noticed that copper is always used for tea kettles, preserving pans and culinary utensils, whilst one never or indeed rarely sees the same articles manufactured from German silver. The fact is that the introduction of nickel into the brass alloy in the presence of moisture appears to set up a galvanic action between the particles of metal, and the consequence is oxidation and decomposition. Notice how very frequently teapot spouts fall off after long use, arising from this fact—that moisture has remained constantly in the bottom of the spouts (see illustration, page 144).

The advantages gained by the use of German silver over copper are: its whiteness, its hardness, and its greater durability where rough wear is required. Its adaptability to the process of hard soldering is also one of its greatest recommendations.

It is now pretty well established that the wanting in ductility of German silver depends partly upon its condition of carbonization—nickel having a peculiar affinity for carbon—and this is specially noticeable in the case of metal used for hollow-ware such as tea and coffee sets, dish covers, entrée dishes, &c. While in the case of spoons and forks, etc., the alloy necessary should be an especially hard one.”

ORIGIN OF THE PROCESS OF ELECTRO-PLATING.

Unlike most inventions that have revolutionised trades, the process of plating by fusion can be traced to the one individual who stands out so pre-eminently, viz., Boulsover. With regard to the invention of electro plating the circumstances are entirely different, so many and simultaneous improvements occurring, and so many patents being taken out more or less at the same time, that it is utterly impossible to pick out any one individual and say he alone invented or brought to perfection this process.

Assuredly the conception of the idea in its earliest form must have been the discovery by Dr. Smee, the electrician, of the power of the galvanic battery to collect or disperse the invisible atoms of pure metal held in solution and to direct them in close compact over the surface of metallic preparations.

This method, when first demonstrated in the scientific world, excited feelings of astonishment—as if the Philosopher's Stone had been discovered, and all the secret workings of nature laid open to the world. Sometime in the year 1840, Dr. Smee gave a practical illustration in his own house of his discovery before eighty of the most scientific men in town, when it seems to have been unanimously agreed by those present that the curtain must shortly now be rung down on the old process of plating by fusion for almost all commercial purposes.

Against one of the walls in the Chapel of Aston Hall, Birmingham, stands what is claimed to be the first electro-plating machine, presented by Messrs. Prime & Son of that city. “This machine, founded upon Faraday's great discovery of Induction, was invented by the late John Stephen Woolrich of Birmingham. It was constructed by Messrs. Prime & Son in 1844, and was worked by them for many years, and until superseded by machines of improved construction and greater power. It is the FIRST magnetic machine that ever deposited silver, gold or copper, and it is the forerunner of all the magnificent dynamo machines that have since been invented. Professor Faraday, on the occasion of the meeting of the British Association in Birmingham, paid a visit, together with some of his scientific friends, to Messrs. Prime & Son's Works, purposely to see the application of this great discovery in practical operation, and expressed his intense delight at witnessing his discovery so early and extensively applied and so successfully carried into practical use. To Birmingham belongs the honour not only of introducing electro-plate, the use of which has extended to every civilised nation, but also the honour of first adopting Faraday's great discovery of obtaining electricity from magnetism,—a discovery that has influenced science and art to an enormous extent.”

INTRODUCTION OF ELECTRO-PLATING.

Undoubtedly Messrs. Elkington & Co., of Birmingham, were the first to turn the invention to solid practical account, both by themselves taking out a patent in 1840, and by buying up almost all the other patents that could be turned to any use in the practical development of the new process. Elkington & Radcliffe had also a secret for “bright-plating,” improved from Tuck's method, by ammonia, which was a valuable agent in discarding foreign matter accumulated during the operation.

No sooner had Elkington & Co. utilised electricity for spreading atoms of gold and silver over the surface of inferior metals than the Old Sheffield Plate manufacturers became alarmed for the future of their industry, which had by this time been firmly established for close on one hundred years. So completely had this firm secured all patents with any practical bearing on electro plating, that any manufacturer now in Sheffield wishing to obtain instruction in the new process and to apply this method in plating his wares, had to go to study on the spot in Birmingham, pay the firm a royalty of £150, and guarantee that he would not deposit less than 1,000 ounces of silver per annum.

EXPERT OPINION ON THE FUTURE OF ELECTRO-PLATE.

The discovery of electro-plating so cheapened the cost and facilitated the production of plated ware that the new process very soon killed the older one. A few of the more conservative of the makers clung to the rolling method for some years, but eventually found the struggle hopeless.

The completeness of the transition was, indeed, dramatically sudden. The compiler of the Sheffield Directory of 1849 was so impressed by its significance that he placed the electro-platers in a special category. The latest serious attempt of the old plate to assert itself may be found in the records of the Great Exhibition of 1851. There the only Sheffield firm which won the approbation of the jury was that of T. J. & N. Creswick. Their exhibits, alone honoured by a prize medal, were "plated by the old process of uniting the metals by heat, with edgings and mountings of silver. The articles were important in size and of good taste." Candelabra of the style of Louis XIV. and Louis XV. being specially mentioned; while the workmanship of dish covers, teapots and trays was "commended as carefully executed, and perfectly adapted for long use."

Sheffield's electro-plating efforts were ignored; but the notice of Messrs. Elkington's collection is instructive as showing how distinguished theorists, clinging fondly to the old, viewed with cautious doubt the capabilities of the new process when it was, in commerce, already vigorously elbowing out its precursor. To a description of Messrs. Elkington's exhibits, and a commendation of the value of electro-plating for ornamental purposes, these hesitating words were added: "The Jury desire to guard against being considered as expressing an opinion on the merit of the application of the electro process of *silver* plating to objects of domestic use. They desire only to commend the artistic application of this discovery, to which alone they

are inclined to think it adapted. At the same time they acknowledge that the application of *gold* by this process is a highly meritorious invention . . .”

The last notification we have of any manufacturers still working in fused plated wares is in the local Directories for the year 1852.

The firm “Christofle,” of Paris, whose business has during the last half century increased so largely, was the first to apply the electro-plating process to articles for household requirements in France. One patent was purchased by them for this method from the chemist Ruoby, in the year 1840, and they also manufactured under royalties owned by Messrs. Elkington whose patents expired in the year 1860.* We are told by M. Christofle that his firm had to fight so many actions at law in defence of the rights they had acquired, that it brought the business almost to the verge of bankruptcy.

METHOD OF SILVER-PLATING BY ELECTRO-DEPOSITION.

The process of electro-plating as carried out to-day is as follows:—Wrought iron tanks or vats, generally from 4 to 8 feet long, and lined with Portland cement, are used to avoid risks of cross-connections and short circuits. The solution in these vats is of the utmost importance to the operator, and is composed of cyanide of potassium dissolved in distilled water, and, in order to secure a suitable deposit, should contain from 2 to 4 ounces of silver to the gallon. To obtain this it is necessary to dissolve the weight required with nitric acid (diluted), then to wash thoroughly the resultant nitrate of silver, re-dissolving it in a strong solution of cyanide of potassium until all disappears and the solution is perfectly clear. Fine silver only must be used for this purpose as well as for the sheet or anode, as the alloy contained in standard silver would completely ruin the plating vat. The dynamo for the current must be specially made for electro-plating and be of a low voltage, the positive pole being carried to the silver sheet and the negative pole attached to the article required to be plated. It is absolutely essential for a sound deposit that the article be perfectly clean, the slightest speck of grease, or even a touch with the dry finger during preparation, being sufficient to cause the silver to blister.

Several processes are in use for cleansing; the most reliable method is to immerse the article in a boiling solution of caustic potash, then rinse quickly through aqua fortis, after which it must be “quicked,” which is done by rinsing through a solution of mercury. This covers the surface with a

* From that date the manufacture of plate from fused metal in France may be said to have almost entirely ceased.

slight film of a bluish grey colour and prevents oxidation. It is then "coated" or struck with a very thin coating of silver by being suspended for a few seconds in the silver solution from a brass rod connected with the negative pole. Then it is brushed with a solution of malt on fine brass wire brushes called scratch brushes. After rinsing through clean water the article is ready for the plating vat, and being attached to copper wires, is suspended in the solution from a brass rod. The electricity passing through the sheet of silver, carries the most minute crystals through the solution and leaves them firmly adhering to the object.

The amount of the deposit on an article is regulated by the length of time that it is allowed to remain in the vat. A mechanical arrangement fixed to the frame work of the vat keeps everything slightly moving backwards and forwards. This prevents lines from striking up the deposited surface and facilitates the speed of the deposit by enabling more current to be used. If an extra thick deposit is required, the article must be taken out and scratch-brushed two or three times during the process. The appearance of the silver is now dead white like porcelain, and when a sufficient weight has been deposited (which is easily ascertained by weighing before and after plating), brightening is accomplished either by scratch-brushing or by transferring the article to a bright-plating solution, this being an ordinary solution with a little bi-sulphide of carbon added, which gives a bright appearance to the silver.

SAVING OF LABOUR CONSEQUENT ON THE INTRODUCTION OF ELECTRO-PLATING.

The advent of the process of electro-plating would in no department of the trade be more welcome than in that known as the Bitt Maker's shop. The making and soldering together of small handles for tureens, feet for salt cellars, sauce boats, tureens, inkstands, caps for joints, and pods for the feet on waiters and trays, etc., etc., was a troublesome business in which it was difficult to be sure of satisfactory results. Whereas these adjuncts were formerly always stamped in two halves filled with lead, and carefully soldered together, they could now be cast whole in German silver, electro-plated, and then fastened on to the various articles. In the early days of electro-plating it is found that this latter method of manufacturing these smaller parts was resorted to long before the bodies of the articles themselves were being made of German silver and electro-plated. Tea urn taps, a never failing source of trouble to the manufacturer as well as to the user, formerly stamped in two halves,

were among the very first of the smaller articles to be cast in German silver, electro-plated, and afterwards soft soldered on to the fused plated copper bodies. The trouble caused by the tea urn taps leaking owing both to the difficulty in fitting the plugs closely and the softness of the copper, which caused the taps to be bent easily, was a very old standing one. It is often a puzzle to collectors why so many tea urns made previously to the discovery of both German silver and the process of electro-plating possess these cast metal taps; the reason is that the manufacturer would recommend the substitution of these new taps for the much worn and often repaired old die-struck specimens that passed through his hands. An illustration is given on page 364 of a large chased Urn, on which is fixed a typical specimen of these cast metal taps. Occasionally the taps are found to have been made of cast metal and close-plated as illustrated below.



Tap, from a Tea Urn, made about the year 1820, with filled silver handle supports, the Tap cast and composed of a brass mixture which has been close-plated. On nose of tap is struck "PATENT."



Teapot Spout, made of German silver, electro-plated. This has dropped off after 30 years' wear owing to decomposition referred to by Mr. A. S. Johnstone (see Page 139). The illustration is also instructive as showing how the tannin in the teapot spout will accumulate until finally it entirely chokes up the passage.

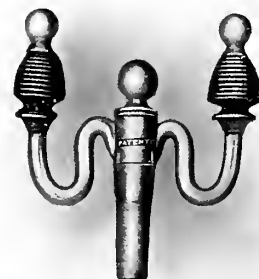

Tea Urn Tap, marked "patent," made of fused plate soldered to a conical shaped brass centre—through this runs a slit, which is opened or closed by turning handle of tap. Made about 1790.

From some cause or other it is quite apparent by their styles and shapes that the large tea urns were made with fused copper plated bodies long after the majority of other goods were being made entirely of German silver and electro-plated. The same remark holds good too with regard to dish covers. Possibly on account of its hardness the workmen employed in raising these larger articles found they could not work up the German silver metal so quickly or so successfully as the plated on copper metal sheets.

PART VII.

LOCALITY OF MANUFACTURE.

WHERE OLD SHEFFIELD PLATE IS KNOWN TO HAVE BEEN MADE.

It cannot be too clearly explained that the description "Old Sheffield Plate" is technically and topographically correct. For upwards of twenty-five years after the discovery of the process no factory for making fused plated wares existed outside Sheffield other than that carried on by Matthew Boulton, Senr., of Birmingham, and it is said that his son during that period was in Sheffield for a time learning the trade in its various branches, under the supervision of one of our earliest and ablest manufacturers, Mr. Morton to wit.* Boulton's firm can be mentioned as being on equal terms with its many Sheffield opponents during the height of the prosperity of the industry. The adaptation of the name "plater" and "French plater"† in old Directories and newspaper notices was misleading, as including factors, retailers, repairers, and those who made buttons, carriage lamp parts, harness fittings and similar smaller articles, chiefly close plated. The only London platers considering themselves of sufficient importance to register their marks at the Sheffield Assay Office were Stanley and Thos. Howard, and this firm's name and device, entered in 1809, is frequently still to be met with on close-plated dessert knives and forks. The large number of Birmingham makers who registered their marks in Sheffield, were nearly all close platers, and their names and devices are still to be found in great abundance on all manner of close plated articles.

Close plating apparently at one time was almost confined to the Birmingham district, its salient features being the execution of plated workmanship on smaller articles, the foundations of which consisted of steel or iron (see page 6). These establishments required an infinitesimally small outlay of capital on stock-in-trade in comparison with the larger and heavier industries known as Sheffield Plate manufactories. Research has invariably resulted

* Mr. Boulton, Senior, died in 1759, and as presumably the making of fused plated wares in Sheffield had for some years previously been attracting considerable attention, it seems only likely that his son would be commissioned to make himself master of this art in the town of its birth.

† French Plating was often confounded with the process of close plating, as in former times the method to-day known as "close plating" was not then so described. Workmen and small masters who worked as close platers called themselves at times "platers" and "French platers." In all probability they would not understand the method of procedure described on page 96, known in Sheffield as French plating.

in the discovery that names often given as London makers of Old Sheffield Plate represent latter-day emigrants to London from Sheffield, either as agents and dealers or as jobbing workers, at a time when the larger shopkeepers needed to get repairs executed for local requirements without the delay and expense of sending them to Sheffield. None of these, therefore, can justly be described as conducting a factory in the generally accepted meaning of the phrase. To take one instance only, concerning a man described as "a well-known London manufacturer called Hattersley" (a distinctly Sheffield name, by the way), of Bennett's Place, Bethnal Green Road. It has been proved that he was a practical man, employing only two or three "hands." Having established himself in London as late as the year 1830 (during almost the last days of the industry), it was impossible to trace him after the year 1858. He had a reputation for making articles from the best quality of metal only, which he purchased from the mills in Birmingham. According to the old books in the possession of Mr. W. A. Ellis (of Birmingham), it was only between the years 1830 and 1845 that Hattersley was purchasing plated metals from his firm, and during the same period Messrs. Garrard, of London, the well-known silversmiths, were also customers, purchasing the metal plated on one side and on both sides of the ingot.*

MAKING OF ARTICLES FROM FUSED PLATE IN NOTTINGHAM.

Concerning what have been casually described as "Factories" existing in Nottingham:—

Through the late Mr. Ellis' instrumentality the writer traced Thomas Oldham, of Nottingham, who is still making measures and tankards in the old fashion (and of fused silver plate) by hammering them up from the sheets on stakes, which business, now almost of centennial existence, he personally has been conducting for close on fifty years. Nowadays his trade is apparently pretty well confined to supplying the requirements of local customers. He states that the business was carried on formerly under the name of Henry Askew (Oldham's uncle), and also, that although electroplate measures can be supplied at less than half his selling prices, still there is a considerable demand for his wares, as they will last three times as long in regular use as those made by his competitors from German silver and electroplated. Askew himself served an apprenticeship to this trade about a

* Garrard's name, also that of A. B. Savory & Sons (both of London), are frequently found on articles of Old Sheffield Plate, namely Entrée Dishes, Dish Covers, etc., made about this period.

century ago, and started business on his own account in the year 1828 in Nottingham. Oldham is unfortunately not able to state where his uncle learnt his business, though he thinks most probably in Sheffield.

Careful examination of these tankards shows that (lacking the silver mounts and thumb pieces of silver) they are now more usually made with mounts of silver fused to German-silver, which are secured to the fused plated copper handles and bodies, and treated exactly according to the methods used by the old Sheffield manufacturers. Oldham and his grandson make these tankards unaided, carrying them through their various stages, without any further assistance in the shape of burnishers, polishers or hand finishers. They also make reflectors for carriage lamps, but to-day there is very little demand for these. Oldham says that no other Plate manufactories other than his small business have ever existed in Nottingham, whilst his full complement of workers has never been more than two or three hands all told.*

The late Mr. Ellis further stated that the making of carriage lamp parts, carriage beading, silver-plated buttons for military uniforms and servants' livery suits from fused plate is still extensively carried on in many parts of the country, and the demand for these classes of articles has practically prevented the entire extinction of the old process. Such businesses as these however, with the one exception of the manufacture of plated tankards, cannot possibly be connected in any way with the manufacture of hollow-ware for decorative and household requirements as carried on formerly by the trade in Sheffield.

OLD SHEFFIELD PLATE IN IRELAND.

Now let us for a time turn our attention from this country and see what can be traced of the manufactured Old Sheffield Plate to be found to-day in Ireland and elsewhere.

Undoubtedly, until quite recently, the best market in which to obtain Old Sheffield Plate was Dublin, and the period of Ireland's greatest prosperity appears to have been contemporary with the flourishing days of the industry; but now, owing to financial and land scares, many of the older families have been reduced to very low circumstances and compelled to part to a great extent with their household goods.

More Old Sheffield Plate would appear to have been retailed in Dublin than in any other city, excepting London. Every manufacturer of any note sought for an opening for the sale of his wares in Ireland.

* At times there have been partners in this business. William Lindley was one. His name ^{LINDLEY} is also found on late Victorian Tankards and Measures made in Nottingham. There are other instances of ^{MAKER} _{NOTTINGHAM} workmen making drinking utensils locally for use in ale-houses in recent times.

In several instances the trade advertisements of Sheffield makers give the names of agencies in London and Dublin only. The retail firm of William Law, who occupied the same premises as Messrs. Hopkins, the jewellers and silversmiths, of Sackville Street, Dublin, is not infrequently confused with the Sheffield firm of Thomas Law & Co., with whom it is improbable that there was any connection whatever. The retail firm "Waterhouse & Co.," of Dame Street, Dublin, was an off-shoot of the various Sheffield Plate manufacturing firms of Waterhouse, who gave up the manufacture of Sheffield Plate in its decadent days, migrated to Dublin, and carried on a most successful all-round business as jewellers and silversmiths. Mr. S. S. Waterhouse, who started this business, went to Dublin in the year 1841; he was one of the Birmingham Waterhouses, different members of which family were manufacturers of silver and plated goods both in Sheffield and Birmingham.

And now as regards the manufacture of fused plated wares in Ireland. Mr. Dudley Westropp, of the Irish National Museum, thinks that no factory existed, but calls attention to the circumstance that, in connection with this subject, in the year 1783 a premium was offered by the Royal Dublin Society for the manufacture of plated goods in Ireland by rollers, it being urged that £40,000 a year could be saved if the goods were produced in Ireland. In November of the following year John Lloyd, goldsmith, of Harold's Cross, Dublin, was awarded a premium of £2 2s. 11d., being at the rate of 6 per cent. on the value of plated goods made by him. This appears to have been the sole response to the offer, and it constitutes the only definite evidence of an attempt by the Irish to make articles of fused plate.

"Silver platers" are mentioned in old Dublin directories of the year 1790 and later, and also in old Cork directories, but research so far has shown these to have been only makers of belt clasps, harness fittings, buttons for uniforms and other inconsiderable trifles, or more probably still, retailers of such articles.

Mr. Westropp points out that after carefully searching the records at the Dublin Assay Office and newspaper notices for the past century-and-a-half he is led to the conclusion that neither the manufacturers in solid silver nor the retailers of silver and plated goods lagged behind in their endeavours to keep pace with the fashions and improvements that were introduced from time to time in England during the period under review. Periodical visits are recorded by the Wardens of the Dublin Goldsmiths' Corporation to London and elsewhere to England in search of new patterns. The local

newspapers contained advertisements of the return of retailers who had imported goods, which, being of the newest styles and in great variety, they trusted would meet with the approval of their customers.

The silversmiths on these visits also secured the services of best London workmen from time to time, and advertised the fact of their having done so, thereby endeavouring to enhance the importance of their establishments. It is significant that throughout this period no mention is ever made of the introduction of workmen versed in the knowledge of the manufacture of articles associated with the process of plating by fusion. Such advertisements always relate to the importation of silver plated goods, and are much on the lines of those here reproduced from old newspapers.

“Faulkner’s Dublin Journal,” May 22nd, 1762 :—

“Henry Clements at his toy shop, Crampton Court, Dublin, has just imported French plate, and japanned candlesticks, neat light English plate crosses and rings for the middle of the table.”

And on December 7th of the same year :—

“Just imported by Henry Clements the newest patterns of Sheffield plated, French plate and enamelled candlesticks, dish stands, etc.”

“Dublin Mercury,” November 24th, 1768 :—

“Henry Sullivan, Dublin, just returned from England and imported plated candlesticks by the best makers, coffee pots, kitchens, salts, snuff dishes (i.e., snuffer trays), cruet frames, coasters, bridle bits, and other articles in the plated way, Dutch kitchens plain with plated furniture.”

“Dublin Chronicle,” October 4th—6th, 1770 :—

“William Fuller, Pill Lane, Dublin, just returned from England and Holland, among other things has plated, paper and leather bottle coasters, plated candlesticks, cruet frames, cups, cans, saucepans, fish trowels, dish crosses, coffee pots, salts, butter boats, sugar nippers and sugar tongs, buckles, boxes, tooth pick cases, bottle labels, lancet cases, and Sheffield knives, razors, scissors, and lancets.”

On December 5th, 1785 :—

“John M’Clean advertises in the ‘Belfast Newsletter’ that he has just imported plated goods, ‘crosses and rings for centre dishes, etc.’”

And on August 12th, 1791 :—

“John Knox, in the same paper, advertises that he has just imported from Sheffield and Birmingham plate and plated goods, dish rings, with and without lamps, tea shells (probably caddy spoons), etc.”

From the “Cork Hibernian Chronicle,” 1786 :—

“John Warner, goldsmith, Cork, who is returned from London and brought a large variety of the following articles, watches, gold chains, plated spurs of all kinds, a few pairs of double plated sportsman’s spurs, Read’s* knives, forks and razors, etc., all sorts of silver plate made in London and Dublin, ‘a new variety of double plated ware.’”

* Read was a Dublin Cutler.

And finally, as showing how, later on, the Sheffield manufacturers had established agencies and warehouses in Ireland:—

“The Star.” Dublin. October 12th. 1824—

“In consequence of the death of two of the partners in the house of Messrs. Roberts, Cadman & Co., Sheffield, the whole of their stock of plated ware, solely of their own manufacture, will be sold at their ware-rooms, 5, Fleet Street, Dublin. R. C. & Co. have for the last 25 years supplied the trade of Ireland, formerly through the medium of Messrs. Clarke & West, and latterly through R. Moore, their agent.

“The stock comprises plateaux, patent covers, supper trays, épergnes, head, foot, side and corner dishes, tea and coffee urns, soup and sauce tureens, liquor, cruet and egg frames, ice pails, bread and cake baskets, candlesticks and branches, salvers, etc., etc., also portable canteen containing a complete dinner and tea service.”

Where workmen are mentioned as having been imported into Ireland in connection with the plating industry, it is invariably in conjunction with the process of close plating.

But previous to the aforementioned premium being offered for the manufacturing of plate in the year 1783, the local silversmiths had been feeling the effects of the extensively imported plated wares, and from the minutes dated November 13, 1773, we gather that a resolution was passed to ask for a repeal of the duty on silver plate, and stating that the large quantity of plated ware imported was detrimental to Irish silversmiths.

(It is not generally known that a duty of 6d. per oz. was imposed on silver plate in Ireland as early as the year 1730, and the figure of Hibernia stamped as a duty mark; in 1807 the duty was raised to 1s. per oz., the sovereign's head being stamped as a duty mark, and the Hibernia mark was still retained.)



1 quart two handled Cup, chased in the Irish style.
By T. Law & Co.
Date 1790. Author.

The platers referred to in the Directories no doubt were close platers, retailers or makers of harness fittings, as Mr. Westropp suggests, but the manufacture of a few articles such as Irish dish rings from plate rolled in this

country would not have presented any difficulty to the clever Irish silversmiths. It seems, however, to be an almost undeniable fact that the making of Sheffield Plate was never established as an industry in Ireland, and the same remark holds good to-day of electro-plated wares. There is unmistakable evidence of out-of-the-way articles being made formerly in Old Sheffield Plate for the Irish market, and not found elsewhere than in Ireland.

The waiter illustrated shows signs of having been chased by an Irish silversmith, both from the style of decoration and from the fact that after being subjected to the process of chasing the craftsman has not, apparently, cared to risk the delicate though necessary process of flat hammering the article again. The small two-handled cup shows chasing of the peculiarly Irish type. Goods chased in this fashion are only to be found in Ireland,



24 in Tray, with florid border, chased in the Irish style, but made in Sheffield.
Date 1818. West & Son, Dublin.

though in this instance the whole of the workmanship may be attributed to Sheffield.

The reasons for the non-existence of evidence in support of the theory that fused plated ware was made in Ireland are not far to seek.

Unlike the French, the Irish makers, had they wished to establish an industry for the manufacture of plated goods, could have hoped to receive no support either from royal bounties or protective duties; without these two encouraging factors it would have taken considerable time to acquire the degree of excellence in workmanship that had been attained by the Sheffield manufacturers. Moreover, the amount of capital required to be sunk in the first instance in order to compete with the numerous fully equipped

manufactories already in existence in Sheffield would have been very great. Beyond this there must needs be large outlay on the cutting of dies, the rolling and fusing of metal, equipment of stamp shops, and the provision of innumerable implements necessary for carrying out minor details. Again, the piercing and fly-punching machines, hammering stakes, accessories for the Bitt platers' room, etc., etc., would have entailed the assembling of manufacturing necessaries on a colossal scale, sufficient to have staggered even the most enterprising supporters of Irish industries in their palmiest days. The foreign manufacturers, too, never attempted to produce anything like the range of articles turned out by the Sheffield factories nor were their workmen skilful enough to apply successfully all the methods adopted by the local manufacturers. Then again, why should the workmen, the best of whom were constantly provided with work at high wages, leave a certainty in the way of employment in Sheffield for a problematical maintenance in Ireland, supposing that an industry had been established in that country? Such a factory would obviously have been unable to compete in price with old established businesses.

Mr. L. A. West, of Dublin, after most carefully studying the question, agrees with the view that Old Sheffield Plate was not made in Ireland. As the firm of West & Son have been manufacturers of silver and retailers of plated goods for over one and a half centuries, his remarks in connection with this subject are well worthy of notice. Had anything in the nature of a plating factory ever been in existence in Dublin his firm's books would have undoubtedly revealed this fact, whereas these show an entire reliance on well-known Sheffield houses for the supply of their requirements. More convincing evidence than this for refuting the supposition that the manufacture of Old Sheffield Plate was ever seriously undertaken in Ireland it would be difficult to obtain.

To give some idea of the extent of the demand from England for Old Sheffield plated goods, a list is hereto appended of various dealers in these wares in Dublin between the years 1795 and 1813, taken from the ledgers of Watson & Bradbury. The value of goods that the retailers purchased from this firm alone during this period amounted in all to the sum of £60,613 15s. 1d. A proportion of the articles would, of course, be solid silver goods, but only a very small one.

To realise the enormous quantity of plated wares that must have been sent into Dublin at that time, it must be borne in mind that the firm cited was only one of some twenty other Sheffield plate manufacturers, who would

presumably be seeking a market for their wares in this district. Large as their trade was in Ireland, it is extremely probable that Messrs. Danl. Holy, Wilkinson & Co. had a very much bigger connection in that country. Even to-day the proportion of Old Sheffield plated goods bearing their mark and made between the years 1784 and 1804 to be found in antique shops in Dublin, vastly outnumbers those that bear other makers' marks, or that can be definitely ascribed to any other firm of manufacturers (see page 433).

It used at one time to be asked, with regard to the quantities of Old Plate to be found in Ireland a few years since, "Where did it all come from?" After perusing these extracts one might almost venture to ask, "Where has it all gone to?"

DATE.	NAME OF MERCHANT.	ADDRESS.	DESCRIPTION.	£	s.	d.
1804	.. Bingham Henry	.. Capel St., Dublin	.. Ironmonger	..	51	8 3
1795-99	.. Binns A. & W.	.. Dublin	.. Do.	..	723	8 10
1799-1813	.. Binns Mrs. Ann	.. Dame-st., Dublin	.. Do.	..	2,004	14 8
1795-1804	.. Binns George	.. Dame-st., Dublin	.. Do.	..	1,079	10 7
1799-1813	.. Binns Wm. Dublin	.. Do.	..	13,101	10 1
1804-7	.. Birmingham Wm.	.. Harcourt-st., Dublin	293	11 4
1795-1808	.. Boxwell Ambrose	.. Dublin	.. Silversmith	..	1,042	18 9
1808-14	.. Cartan & Hawthorn	.. Pill-lane, Dublin	.. Hardware Mct.	..	136	5 8
1795-1803	.. Clarke John	.. Dublin	.. Jeweller	1,490	10 8
1802-12	.. Clark Wm. Sackville-st., Dublin	.. Goldsmith..	..	1,615	2 3
1806-13	.. Connor Thos.	.. Dublin	.. Jeweller	928	19 1
1795-98	.. Cormick Mrs. Ann	.. Do.	.. Goldsmith..	..	313	18 3
1796-1810	.. Daly John Do.	.. Silversmith	..	837	10 8
1795-1805	.. De Landre Bartw.	.. Do.	.. Goldsmith	240	7 4
1795-1800	.. D'Olier Jerh.	.. Do.	.. Do.	710	2 9
1808-11	.. Franklin Joshua	.. George-st., Dublin	.. Do.	262	8 8
1799-1813	.. Gatchall Saml.	.. Pill-lane, Dublin	.. Ironmonger	..	539	14 0
1800-03	.. Hague & Beaumont	.. Fishamble-st., Dublin	.. Woollen Ftrs.	..	20	9 1
1808-13	.. Hamy Wm.	.. Dame-st., Dublin	.. Jeweller and Watchmaker	..	886	14 0
1807-12	.. Henderson Jas.	.. Westmoreland-st., Dublin	.. Watch and Clock maker	..	362	11 0
1795-1805	.. Hewitt James	.. Dublin Jeweller	318	0 3
1799	.. Janillion & Fagan	.. Capel-st., Dublin	.. Perfumers	..	111	16 0
1812	.. Johnson Thos.	.. Dublin	.. Watchmaker	..	96	12 8
1795-1813	.. Kavanagh Jno.	.. Do.	.. Goldsmith..	..	2,014	5 7
1801-12	.. Keene Mrs. Jane	.. Do.	.. Do.	3,671	17 9
1795-1811	.. Keene John	.. Do.	.. Do.	4,072	8 2
1795-1801	.. Keene Wm.	.. Do.	.. Do.	1,243	12 11
1795-1812	.. Law Wm. Do.	.. Do.	8,206	11 11
1797-1804	.. Manning J. & H.	.. 60, Dame-st., Dublin	.. Jeweller and Goldsmith	..	1,116	8 1

DATE.	NAME OF MERCHANT.	ADDRESS.	DESCRIPTION.	£	s.	d.
1807-9	.. Manly Jas. Dublin Jeweller and Silversmith ..	78	17	3
1808-11	.. Molyneux Jos. Skinner-row, Dublin Watchmaker ..	147	14	8
1795-6	.. Moore Ambrose Dublin Goldsmith ..	636	4	8
1806-12	.. Morgan Thos. Skinner-row, Dublin Silversmith ..	245	12	6
1806-9	.. Morgan Wm. Dublin Watchmaker ..	423	15	9
1812	.. Mullen Michl. 68, Dame-st., Dublin Jeweller ..	500	3	8
1799-1802	.. Murphy Bryan Kenedy's-lane, do. Ironmonger ..	172	11	9
1804-12	.. Murphy Richd. Do. do. Do. ..	237	6	4
1807-9	.. McClean & Hull Dublin	244	10	0
1812	.. Nowlan John New Row, Dublin Hardware Mct. ..	13	15	6
1804-9	.. Osborne & Keville Nassau-st., do. Jewellers ..	1,589	3	4
1803-13	.. Osborne Wm. Do. do. Do. ..	1,542	19	9
1799-1802	.. Parker Wm. Dublin Ironmonger ..	180	10	9
1802-13	.. Peter Walter Grafton-st., Dublin Jeweller ..	1,638	0	5
1810-12	.. Petrie James Dame-st., Dublin Do. ..	286	18	8
1795-1803	.. Rice Edward Dublin Goldsmith ..	249	9	11
1803-7	.. Roth Robt. Westmoreland-st., Dublin Jeweller ..	766	10	2
1795-1801	.. Tudor Jno. Dublin Goldsmith ..	163	14	1
1808-12	.. Twycross John 69, Dame-st., Dublin Do. ..	565	15	2
1795-1813	.. West Mattw Dublin Do. ..	1585	14	1
1805-10	.. Whitstone Kenedy's-lane, Dublin Ironmonger ..	184	18	6
1799-1813	.. Williams Robt. Grafton-st., do. Goldsmith ..	1186	10	3
1805-10	.. Williamson Lewis 68, Dame-st., do. Jeweller ..	265	19	9
				<u>£60,613 15 1</u>		

OLD SHEFFIELD PLATE IN SCOTLAND.

These remarks concerning the making of Old Sheffield plated ware might, with but little alteration, be applied also to Edinburgh and Glasgow. As regards the quantity sold in Scotland until the termination of the industry the books of the firm referred to previously show that an increasing trade was being carried on north of the Tweed until the termination of the industry, and it is hardly possible that anything but a very small establishment for repairing and jobbing generally existed locally. The value of goods sold by Watson & Bradbury in Scotland between the years 1795 and 1812 amounted to £17,631, the most extensive purchasers in Edinburgh then being Messrs. Morton & Milroy, jewellers, 35, North Bridge Street, and in Glasgow, Robert Gray. No extensive dealings with the metal-smiths can be traced, and certainly no plate rolling mill was ever in existence in Scotland, or it would have become known ere this. The local silver workers, therefore, here as in London, had to endure the invasion of their market by the Old Sheffield platers. On the other hand the Scottish public would hail

with pleasure the importation of goods, the artistic appearance of which, no less than the economy afforded by their use, would appeal both to their good taste and to their well-known habits of thrift.

Mr. Andrew Sharp, of Edinburgh, has kindly furnished the following particulars. Mr. Sharp's information is of value, both on account of the interest he has taken in the subject and because, during his 30 years' experience in the trade, he has seized many opportunities of recording details concerning interesting specimens that have passed through his hands, both in antique silver and Old Sheffield plate :—

“There exists an entirely misleading supposition that among its various industries Edinburgh was at one time the centre of a group of manufacturers devoted to the production of Sheffield Plate. It is true that for two or three centuries goldsmiths, silversmiths and clock-makers were a strong and vigorous craft there, the producers of much excellent ware now fully recognised by connoisseurs and others. Considering the comparative cheapness of Sheffield plate and its superiority in appearance over pewter utensils (of which considerable quantities were made in the shops of the hammermen or whitesmiths), the adoption of the new invention by masters anxious to keep their men and their businesses together would have been natural. But after considerable investigation no proof is obtainable that Sheffield plate was produced in Edinburgh. It is possible that an isolated piece may occasionally have been made, but evidence of any general and systematic manufacture by specially trained men is wholly lacking. Inquiry has been made amongst the oldest workmen in the city with experiences covering a period of from 50 to 60 years, and had the industry ever existed, they must have heard about the makers and have seen some tools and dies, perhaps even have known of some of the pieces remaining amongst the stocks of the city silversmiths. But these old workmen all concur in saying that not to their knowledge did they ever hear of the local manufacture of Sheffield plate or see it except in instances where it was brought into the workshops for repairs. In the old city directories are to be found the names of men who are described as ‘platers,’ a trade carried on in connection with that of the coachmakers, harness makers and ironmongers. The productions of these men were usually close-plated iron work used in harness making, coach building and articles supplied to other trades. They had neither the workmen nor the tools to produce Sheffield plate even if they had the connection for it. An old and interesting copy of the *Edinburgh Courant*, in the early part of the 19th century, contains an advertisement informing the public that one of the partners of a famous firm, now defunct, had just returned from Sheffield with a supply of the finest plated goods, clearly showing that it was necessary at times to visit the seat of manufacture for these goods, which were evidently not being made locally.” Mr. Sharp goes on to say :—

“An Edinburgh expert, to whom I am indebted for the investigations here recorded, tells me that after many years' experience in handling Old Sheffield Plate he has never seen nor heard of a piece that could be located as of Edinburgh manufacture, or indeed of Scottish manufacture at all.”

From the Sheffield papers of October 27th and 30th, 1821, we learn that “the Burns Society of Sheffield presented the poet Burns' widow with a pair of silver candlesticks, also snuffers and tray, of the newest pattern and best workmanship, made by Watson & Bradbury, in Mulberry Street.” The

inscription (engraved by Mr. Tompkin) read, "The gift of a few Scots in Sheffield to the widow of Burns."

"He passed through life's tempestuous night,
A brilliant, trembling northern light,
Through years to come he shines from far,
A fixed, unsettling polar star."—*J. M.**

One paper mentions the name of Watson, Pass & Co. as being the makers of the snuffer tray.

It would be interesting to know if these articles are still in existence.

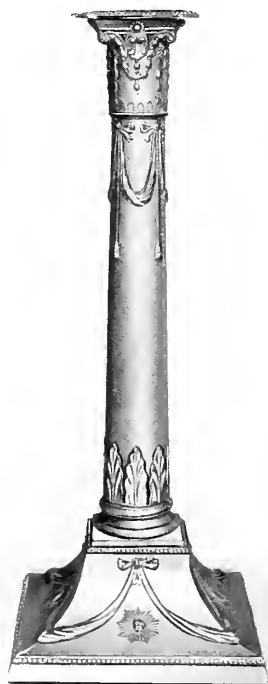

12 in. Adam Candlestick, by
M. Fenton & Co.
Date 1777.

OLD SHEFFIELD PLATE IN AMERICA.

That there must still be in America a quantity of genuine Old Sheffield Plate there can be little doubt, as from the years 1795 until 1831 the export trade from Sheffield was considerable and consistent. The ledgers of T. Bradbury & Sons show that Mr. George H. Newbould (their agent in America) sold in the year 1826 alone goods to the amount of £4,671 7s. 5d.; in 1828 and 1829, £6,000; and in 1830, £2,058 9s. 7d. About that date this export trade to America practically ceased, though as late as 1831 both the firms of Taylor & Brown in Baltimore, and William Antony Rasch in New Orleans, still continued to purchase a few Old Sheffield plated articles.

A diary written by the author's grandfather is still in existence relating his travels on business in both America and Canada about a century ago. The candlestick here illustrated is a duplicate of one in Old Sheffield Plate brought over to Sheffield by an American some 15 years back to be reproduced. He stated that it had been carefully preserved by the family, who originally purchased it in America. The date of its manufacture is between the years 1770 and 1780.

The amount of business done by the firm of Watson & Bradbury with America, and the names of the customers in different towns between the years 1795 and 1825 are of sufficient interest to produce in detail. There is an item of £13 3s. 6d., still left open in the firm's books, dating from the year 1815, to the debit of Mr. Thomas Willetts, Junr., of New York. Writing

* James Montgomery.

to Sheffield on the 30th September, 1816, Mr. Newbould, the agent, says, "I have not seen him for a long time, and 'expect' that he has left New York." Under these circumstances one must naturally suppose that Mr. Willetts had left the city "for good."

					£	s.	d.
1795-1803	.. Jonathan Ogden New York	..	2,396	10	0
1801-1816	.. Richards, Upson & Co. "	..	1,354	12	8
1806-1807	.. Lemuel, Wells & Co. "	..	1,584	19	8
1805-1807	.. Thos. Warren "	..	398	2	9
1807-1810	.. Thos. Willetts, Junr. "	..	472	8	6
1816	.. Jas. S. Bailey "	..	557	4	8
1815-1817	.. B. & P. Cooper "	..	415	11	10
1816-1819	.. Fellows & Younge "	..	2,241	6	9
1816-1819	.. Hyde & Nevins "	..	1,490	8	3
1815-1818	.. Stollenwerk & Bros. "	..	584	2	7
1821	.. Erastus Barton & Co. "	..	124	13	6
1818-1824	.. Pelletreau & Upson "	..	2,568	10	3
1821	.. Jerh. Cooper "	..	90	7	0
1820-1824	.. James Fellows "	..	674	2	10
1824	.. Fellows & Read "	..	123	11	5
1824	.. Isaac Marquand "	..	339	13	5
1816-1817	.. Jacob S. Platt "	..	269	19	10
1817-1818	.. Richards, Taylor & Co. "	..	486	8	9
1824	.. Stephen Richards "	..	111	13	8
1822-1824	.. E. & S. S. Rockwell "	..	663	3	1
1817-1818	.. Stout & Platts "	..	431	12	6
1824	.. H. Smith "	..	60	5	7
1816-1824	.. Taylor & Hinsdale "	..	2,721	4	3
1823-1824	.. Thomas & Smith "	..	259	7	0
1819-1823	.. Henry Younge "	..	1,190	0	1
1807-1811	.. John McMullin Philadelphia	..	162	12	3
1815	.. Michl. H. & Thos. Anthony "	..	547	3	9
1815	.. Fletcher & Gardiner "	..	416	18	6
1816	.. Robert Kid "	..	655	13	9
1819-1824	.. Gardiner, Veron & Co. "	..	1,095	2	5
1822-1824	.. Edward Lownes "	..	611	8	6
1819	.. A. Rasch & Co. "	..	614	7	9
1819	.. Rasch & Willig, Junr. "	..	614	7	9
1807-1816	.. Eben. Moulton Boston	..	126	9	8
1810	.. John McFarlane "	..	232	11	2
1816	.. Baldwin & Jones "	..	220	17	4
1816-1817	.. Davis & Brown "	..	623	10	3
1816	.. Farnham & Ward "	..	82	5	8
1810	.. Richd. Norris Baltimore	..	78	5	6
1800-1801	.. Chas. Banks Charleston	..	192	19	0

Old Sheffield Plate does not appear to have found a great market in Canada years ago, the only purchaser who can be traced in that country being :—

1816	.. Jasett Devight Montreal	..	£113	13	6
------	-------------------	----	-------------	----	------	----	---

The trade with the West Indies, however, was of importance, considering the small size of the country, as the following extracts go to prove :—

					£	s.	d.
1795-1797	.. James Clark Kingston, Jamaica	..	917	2	3
1796-1798	.. James C. Colthirst	593	13	6
1796-1812	.. Joshua Rouse	2,534	11	5
1795-1801	.. Geo. Marshall Spanish Town,	819	19	9

Mr. E. Holbrook, of New York, who recently acquired the Wolsey collection of Old Sheffield Plate; has kindly furnished the following information concerning this list of American customers:—

“Undoubtedly B. & P. Cooper and Jerh. Cooper were the founders of the house afterwards known as Cooper, Fellows & Co.; Fellows & Read were also of that firm and of the later firm of Read, Taylor & Co. Both these firms were in existence twenty-five or thirty years ago, but are now entirely out of business.

“There is one firm mentioned in the list, however, that is of considerable interest, Erastus Barton & Co., to whom the firm sold goods in 1821, were the founders of the house now known as Black, Starr & Frost. Erastus Barton & Co. were succeeded by Frederick Marquand, then by Marquand & Barton, then Marquand & Bros., then Marquand & Co., who in turn were succeeded in 1839 by Ball, Tompkins & Black, then Ball, Black & Co., in 1851, and then Black, Starr & Frost, who are still in existence and doing business at 39th Street and Fifth Avenue, and are one of the prominent houses in the trade.

“I find, however, that most of the houses are out of existence and some of them have almost passed out of the memory of anyone of the present date.”

OLD SHEFFIELD PLATE ON THE CONTINENT—IMPORTATION INTO ENGLAND, AND MANUFACTURE ABROAD.

Numerous specimens of Old Sheffield plated ware are to be found in the various cities of Europe, many of which came originally from England.



Old Sheffield $3\frac{1}{2}$ gill Teapot, made by N. Smith & Co.
Date 1808. Miss Hobson, Sheffield.

The teapot here illustrated was purchased in a dealer's shop in Rome in the year 1896 by the author. It was identified later as being of Sheffield origin, from a duplicate in silver purchased in Liverpool bearing the date letter for the year 1808, made by N. Smith & Co., of Sheffield. The tea urn illustrated belongs to Mr. Alfermann, of Berlin, and was noticed by the

author when at his house in 1907. The owner purchased it at a sale in that city for 50 marks some few years since. It is in perfect preservation, and a fine specimen of the heavy oak and shell mount pattern so prevalent in the earlier part of the 19th century. Other illustrations could be given of numerous pieces purchased by the writer in Hamburg, Holland, Belgium, and elsewhere on the Continent. The old ledgers belonging to Watson & Bradbury show that a fair export trade was also carried on during the years 1790-1815 with Continental cities, the goods being shipped to Hamburg, Amsterdam, Antwerp, Altona and Lübeck. A few of the more important shipments to these various towns are detailed here. This trade with the Continent had entirely ceased by the year 1825.



5 quart Tea Urn.
Date 1817. Mr. Aliermann, Berlin.

					£	s.	d.
1798	.. Chas. Fred. Christ Hamburg	..	27	17	0
1797-1806	.. Dellevie Bros. "	..	1,454	9	11
1801-1806	.. Bernhord Lion Emden "	..	448	3	5
1796-1804	.. Franckel & Co. "	..	1,195	6	5
1798	.. And. Wilh. Hermann "	..	19	6	0
1802	.. S. Heyman & Co. "	..	139	5	0
1804	.. Hulsenbeck Runge & Co. "	..	2	12	0
1803-1804	.. Andreas D. Ludemann "	..	157	14	0
1800-1806	.. Carl August Resenhauer "	..	1,040	17	5
1804	.. Adolph Fred. Rosenhauer & Co. "	..	115	4	4
1797-1804	.. Ferdinand H. L. Schultz "	..	1,140	0	8
1800	.. Wm. Chris. Sanders "	..	146	3	9
1800-1805	.. Walker Bros. "	..	334	3	6
1809	.. Johann Chris. Wilh. Wolff "	..	53	16	2
1802	.. Geo. Ferguson Amsterdam	..	103	0	0
1802	.. Peter Wm. Glad. "	..	97	15	6
1802	.. Lurasco Bros. "	..	68	15	0
1802	.. C. Mertz "	..	24	11	6
1802-1804	.. Rigail & Roullaud "	..	245	0	7
1802-1804	.. Tuffin & Ciovsno "	..	140	2	8
1795-1805	.. Isaac Bravo Altona	..	851	19	0
1804	.. Johann Hermann Von Duhn Lübeck	..	24	19	0



4-quart Tea Urn, with hand-chased base and mask supports to handles and spout.
Date about 1762. O'Donoghue, Torquay

The Tea Urn illustrated is one of the earliest designs made in Sheffield Plate, about the year 1762. Of these there are a good many varieties still to be met with. On account of their extreme lightness—absence of silver shields and mounts—as also to their somewhat un-English shape, they are frequently described as of foreign make; such, however, is not the case, as duplicates of the taps, knobs, and mounts have frequently been found on other specimens of this date made in Sheffield. Articles of fused plate made abroad earlier than the year 1800 are to-day scarcely to be met with in England. So far a close examination of these urns has failed to reveal any maker's initials thereon, as is usual with the smaller contemporary plated articles. It is difficult, therefore, to state accurately to which of the manufacturers we may ascribe them.*

The importation into Great Britain of ware made from fused copper plate did not make headway until about the year 1820, from which date until the termination of the industry a fairly large number of articles must have found their way into this country from France. But these are nearly all manufactured from very sparsely plated metal. Only in a few instances have articles bearing silver-threaded edges been found by the writer, and in no case has an article with an inlaid silver shield been discovered. Presumably the foreign manufacturers were not sufficiently competent to undertake this very delicate little piece of workmanship. The prices of the articles destined to be sold in this country must have been extremely low and cheaper than anything to be found in English goods. The gauge of plated metal used by the French was usually much thinner than that in general use in this country. The copper, too, is of a redder tinge, consequent on its containing less alloy.

* A very fine specimen of silver Tea Urn with body similar to above, but with chased floral decoration and pierced base, hall-marked in London, 1764, bearing maker's initials (Louisa Courtauld), is to be seen at the Sir John Soane Museum, London. Many old Sheffield urns, similar to this in design and made at the same period, are to be met with to-day.

Of the foreign made specimens of Old Sheffield Plate found in England to-day the majority can be traced as importations from France ; the name occurring most frequently on them is that of Balaine. Balaine himself is reported to have died some time between 1860 and 1870. His firm's business was known to be in existence in the year 1810. Messrs. Boulenger & Cie., established in the year 1810, were also large manufacturers of Old Sheffield plated goods in Paris nearly a century ago. They acquired a large export trade all over the world, using as a trade mark



As concerns other Continental makers whose goods have travelled as far afield as England, little or no importance can be attached to them. The name Rosenstrauch has been met with on a very large fused plated tray illustrated below, also on other articles, including an oblong plain gadroon mounted cake basket, gilt inside—undoubtedly of foreign manufacture—beside an Eagle, but this mark is so indistinct that it has not been possible to say to which nationality it belongs, most probably, it is either Austrian or German.

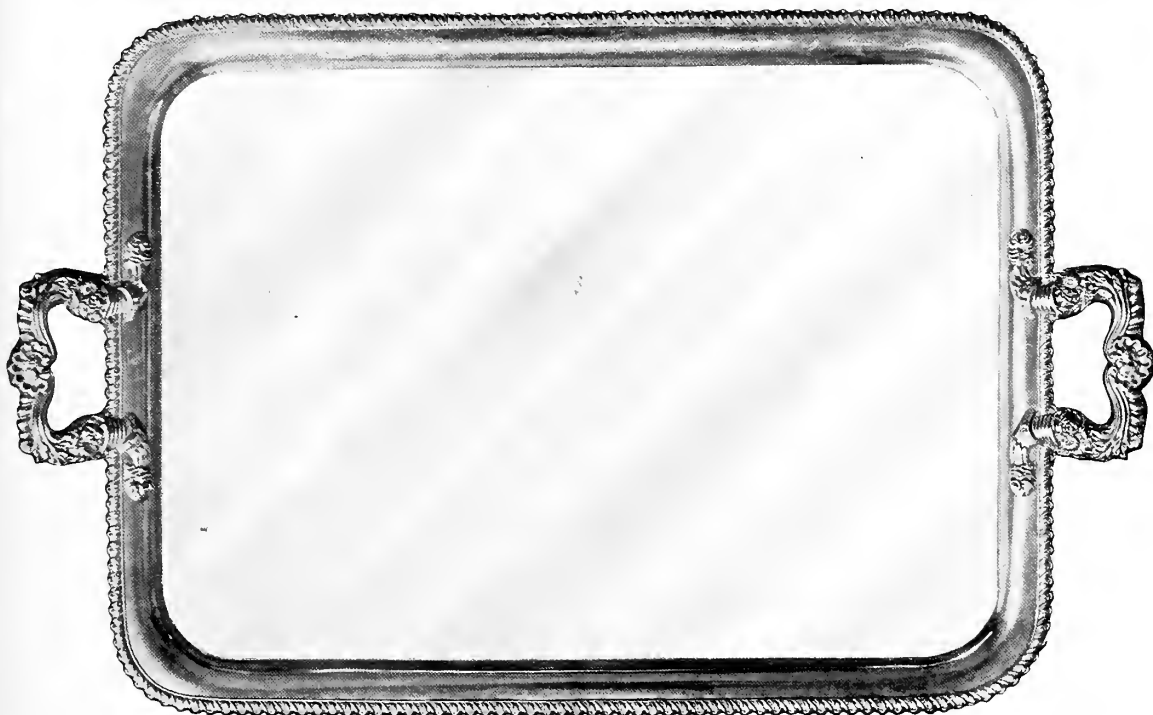

26½ in. Oblong Gadroon Tray, with filled silver mount, probably made in Austria.

Date 1820—1830.

Butt & Co., Chester.

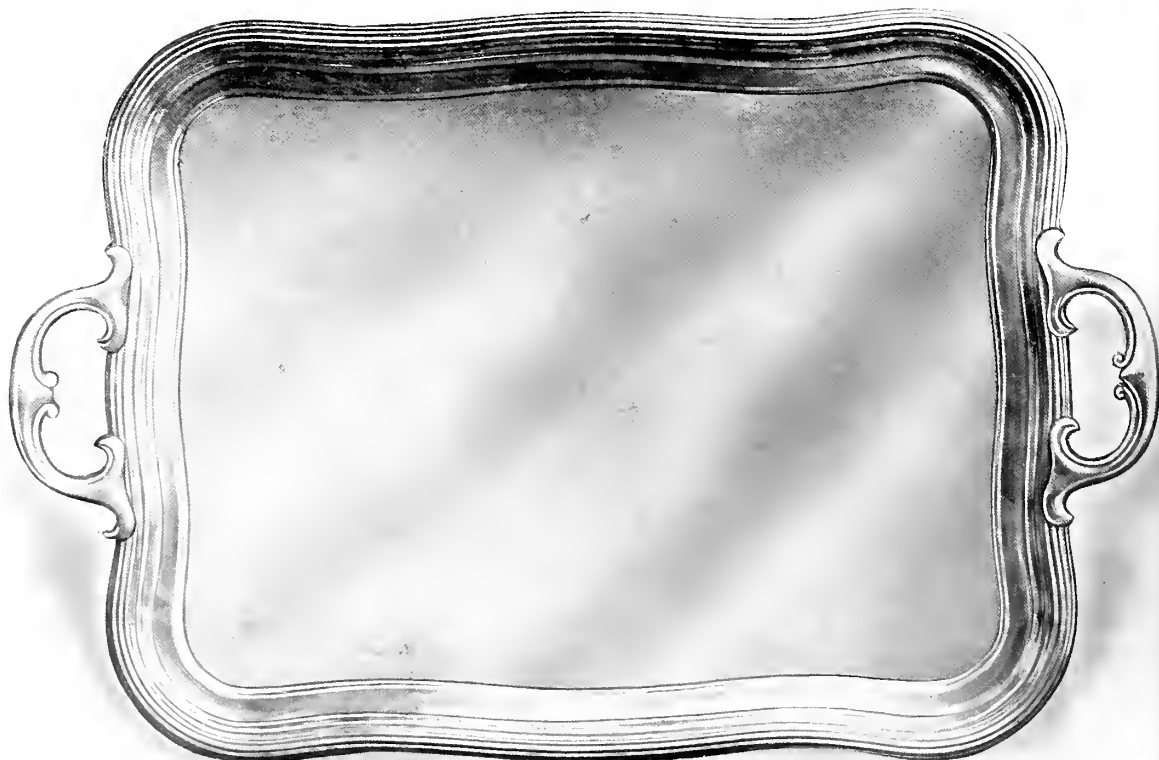

22 in. Oblong Plain Tray, with Threaded Mount, by "Petz" (made in Russia).
 Date 1825-1835. Butt & Co., Chester.

Two rather interesting Russian marks are here reproduced. The first one is taken from a plain shaped swage and threaded mount 22 inch tray with handles, the name of the maker **ПЕТЪ** being translated means "Petz," probably a German, whilst the letter stamped on the body of the Eagle  denotes that this manufacturer was an imperial warrant holder to the Emperor Nicholas I. of Russia. The tray must therefore have been made between the years 1825 and 1855, the period during which the Czar Nicholas I. reigned.

The next mark is taken from a Russian Samovar. The top line denotes an abbreviation of the town "St. Petersburg." The second line is an abbreviation denoting "silver plate store" (warehouse or shop?). The third gives the manufacturer's name, which if pronounced in English would sound like the expression of the word "Charkoff."

С.П.Б. *
М.НАК.СЕ
ЧЕРКОВЪ

* The writer is much indebted to Mr. Joseph Spiridion, of Cardiff, for much help in deciphering and interpreting these Russian marks.



Oval wire work Wine Glass Holder or Fruit Dish, 16 in. long, with end handles, by Levrat, Paris.
Date 1810—1820. Franklin & Hare, Taunton.

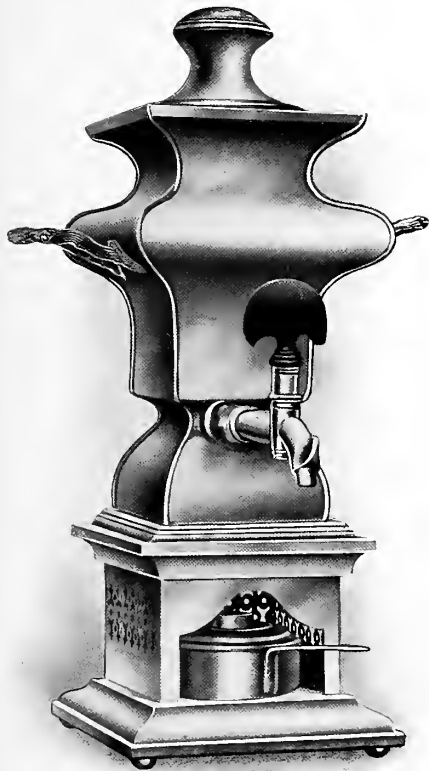

3-pint Samovar, altered to be used with a lamp instead of charcoal. Made in Russia.
Date 1810—1820. Author.



Fish Slice, with pierced centre and wood handle.
By Balaine, Paris.
Date 1810. Mr. W. P. Belk, Sheffield.



Toothpick Holder, in form of a Swan,
made in France.
Date 1815—1825. Author.

MANUFACTURE OF SHEFFIELD PLATE IN FRANCE.



4-quart Soup Tureen, with melon pattern knob, and engraved coat of arms. Made in France.
Date 1820—1830 Author.

manufacture the outcome of individual manipulation, as was the case with the contemporary English gold and silversmiths. Factories such as we understand them to-day for the production of silver goods did not exist (at all events in the 17th and early part of the 18th century).

The privilege of Government License was abolished in Paris at the beginning of the 19th century and to the extension then given to the

The author is indebted to M. Pinton, of the firm of Messrs. Ch. Boulenger & Cie., of Paris, for great help in the compilation of the following interesting information on the subject of plated ware in France.

The goldsmiths and silversmiths of the 17th and 18th centuries held licenses under the Government, and they invariably lived in the Louvre. The articles that they produced were throughout their various stages of

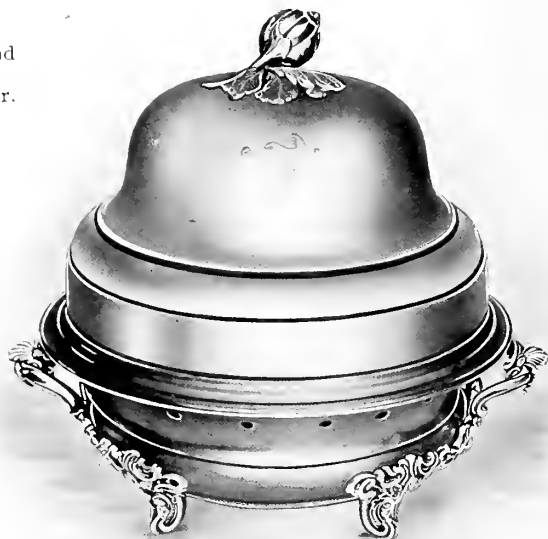

12 in. plain Dish and Cover, with warmer, heated by charcoal, by "Janty," made in France.
Date 1825—1835. Galton, Christchurch.



7½ in. Dish and Cover, with engraved crest, made in Paris.
Date 1815—1825. Author.

11 in. Dinner Plate, with silver mount, and threaded silver underneath edge (one of the few specimens of foreign make with silver borders). By "Gandais."
Date 1825. Author.

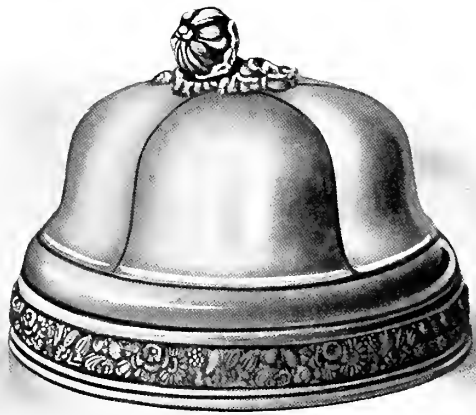

12 in. Shaped Plate Cover, with florid mount, made in Paris.
Date 1825—1830. Author.

Coaster, with ornate border, made abroad.
Date 1830—1840. Mr. Waldeck, London.

silversmiths' trade was due the opening of manufactories of plated goods by Boulenger, Balaine, and some others. Most of these firms had not, however, a very long life. As was the case with the local Sheffield manufactories, they, with the exception of the firm of Boulenger, ceased to exist, upon the introduction of the process of electro-plating, soon after the year 1840.

One process of plating inferior metals with silver was apparently originally of French origin, and was discovered in France at the beginning of the 18th century, the Regent of France at that time taking a controlling



Oval Shaped Dish Cover, engraved crest, with handles in form of an eagle. Of a set of six—two 34½, one 44½, one 46, one 49½ and one 54½ millimètres. By Durand, Paris
Date 1830. Phillips, Bristol.

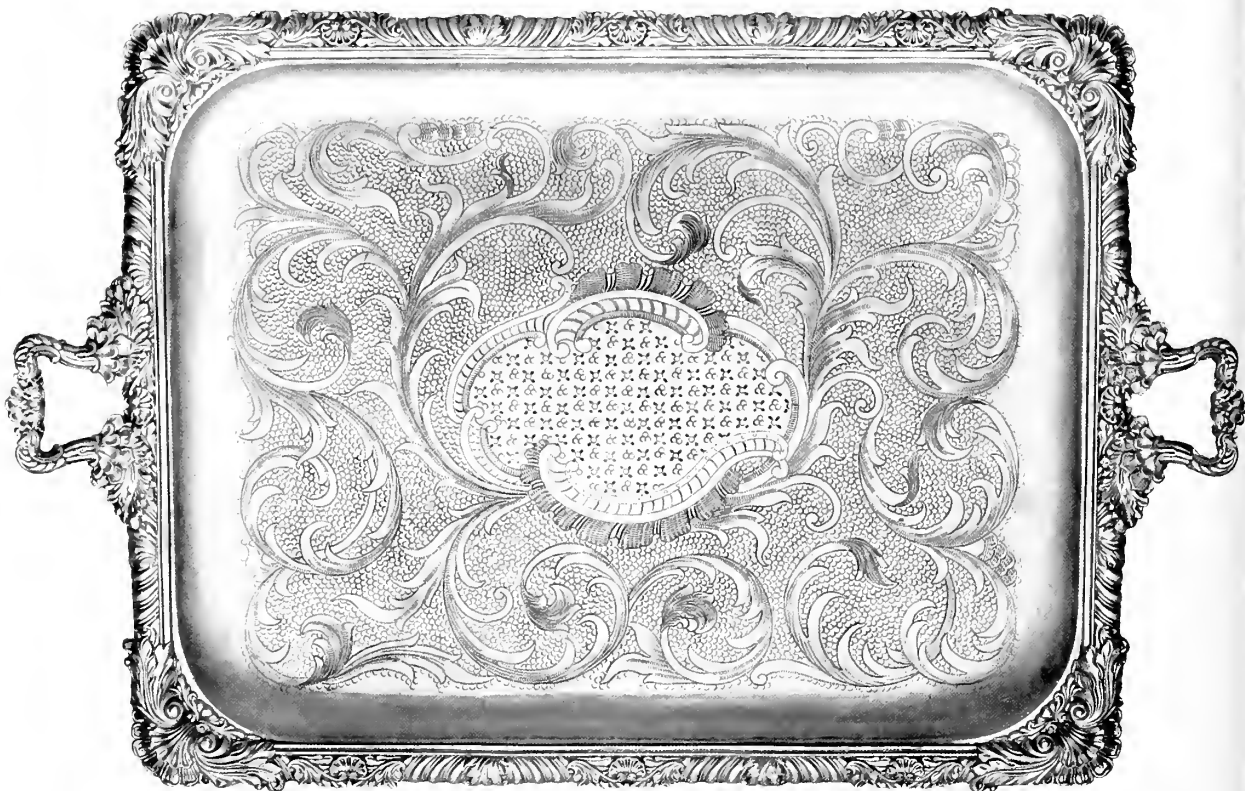

24 in. Oblong Chased Tray, with florid mounts. As is frequently the case with Foreign examples, the metal is too thin for an article so large. Being insufficiently flat hammered, it is much out of shape. By Balaine, Paris.
Date 1820—1830. Mr H. C. Casley, Ipswich.

interest in its production. This process, described on page 96, came to be known in England under the designation of "French plating." The method in use by the latter day Sheffield platers, though akin to it, was a greatly improved form of this original French invention.

It is not until the year 1770 that anything definite can be traced as to the uses to which the French applied Boulsover's invention. In this year a manufactory was established in Paris at the Hotel de la Fère, Rue Beaubourg au Marais, afterwards being transferred to the Quartier Pont aux Choux, Rue Popincourt, for the manufacture of silver plated dishes, under royal patronage. This business was originally conducted by one Degournay, engineer to the King, and it continued to be successfully carried on until the process of plating by fusion was superseded by the newly-invented method of electro-plating, about the middle of the 19th century.

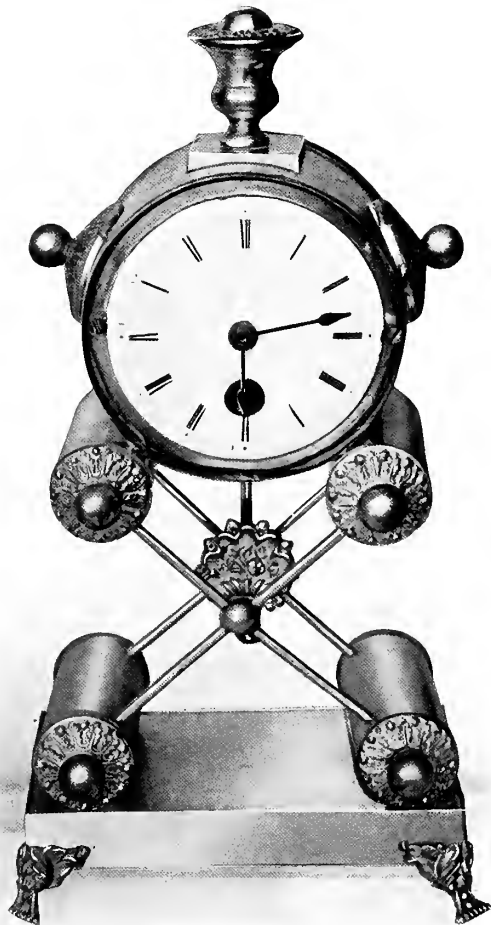

Clock, 9 in. high, all the visible parts made from plated copper, with porcelain face, and tinned underside. Made in Paris.

Date 1815—1825.

Mr. B. B. Harrison, Sevenoaks.



3-gill Teapot, with mask lip, made in Paris.
Date 1820. Author.



"Altar Cruet," one of a pair,
6 in. high, made in France.
Date 1810-1818. Author.

The establishment of this manufactory in Paris so alarmed the contemporary makers of heavy silver goods that in the year 1772 they addressed a note of protest to the Duc de Vrillière against the introduction of the manufacture of this class of wares into Paris. This new industry was, however, destined to receive further royal patronage. The very expensive solid silver ware then in vogue was too costly for the French middle classes, and Louis XVI., himself of a mechanical turn of mind (he devoted his spare moments to mastering the intricacies of the locksmith's trade), was eager to supply their wants with some cheaper form of plate for table use. He therefore decided on financing a manufactory of his own, and in due course erected a plating establishment in the Hotel Pomponne, Rue de la Verrerie. This establishment was conducted by Marie Joseph Tugot and his son-in-law, Jacques Daumy. The firm flourished to such an extent that Louis XVI. allowed them to entitle the plate as of "royal manufacture." The Goldsmiths' Corporation, on the other hand, jealous of the success of this firm, exerted their influence with the "Court des Monnaies" to make an attempt to restrict the extent of the privileges acceded to them.

This had the contrary effect, however, as through the King's influence the firm were granted "by letters patent dated March the 17th, 1787" permission to both gild and plate brass and other kinds of vessels suitable for use as utensils for the table.*



Covered Sugar Basin, with silver threaded edges, one of the few specimens of foreign articles made in this way. By Balaine, Paris.

Date 1815-1825. Franklin & Hare, Taunton.



Wine Cooler, 12 in. high, with masked handle supports and fluted body, by Balaine, Paris.

Date 1820-30. Mr. W. H. Rickatson, London.



1 Pint fused plated Spirit Kettle and Stand, for use when travelling, of French make, purchased in Italy.

Date 1828.

Paget, Cheltenham.

* It is interesting to note that the French manufacturers had to face the same difficulties as the early platers in Sheffield encountered, namely, the opposition of the then existing silversmiths when they introduced plated wares for table use into a market that had previously been held almost exclusively by them.













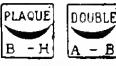



There are still to be seen in Paris, at the Musée des Arts Decoratifs, some specimens of the goods turned out from this factory. Amongst others may be mentioned a very pretty soup tureen, with fluted body (formerly the property of M. Alfred Darcel, previously a Director of the Cluny Museum).











It was mainly due to the initiative and great skill of Messrs. Tugot and Daumy that the middle class citizens of Paris were able, as far back as the year 1787, to display on their tables articles of plated ware of artistic design made locally. Previous to this date we may take it that nearly all the articles of fused plate in France had been manufactured in Sheffield.

So many old fused plated articles manufactured abroad are to be met with in England to-day, that it has been deemed advisable to illustrate a somewhat varied selection of them. The collector may thereby the more readily accustom himself to the shapes and styles which were prevalent amongst the foreign manufacturers. The majority made in France bear the names of Balaine, Durand, Gandais and Levrat, who were the more prominent of the French makers. Levrat's workmanship is perhaps the best. Occasionally articles of his make with filled silver florid mounts and silver edges are met with which—excepting that they lack the rubbed-in silver shields—compare very favourably with Sheffield workmanship of the later period. The crests appear to have been stamped separately in thin silver, then filled and soldered on to the articles. Fused plate made in France is readily identified by the marks always found thereon.

The name of the maker was usually struck as well as his trade mark, initials, or other device. The marking of any goods plated with silver was in France obligatory, and they had either to bear the words **DOUBLÉ** or **PLAQUÉ**. The makers were also compelled to stamp on plated goods the thickness of silver, viz., **10^m** **10^m** **10^m** **20^m** (E, M, & EM are abbreviations of Dixième). The marks indicate that to an ingot of copper weighing 9 or 19 kilos. was applied 1 kilo. of silver. **30^m** and **40^m** are indicative of the poorest qualities of plating, viz., a deposit of 1 kilo. of silver to 29 and 39 kilos. of copper. At the present time in France, although manufacturers of plated goods are no longer compelled by law to indicate on articles the amount of silver deposited, this custom is still adhered to.

In a few instances will be found the words **GARNITURE ARGENT**, this denotes that the articles bearing these words have had silver borders (filled with solder) attached to them.

Maker's Marks.	Description of Article from which Marks are taken.	Where manufactured.	Approximate date of manufacture.
	From oval pierced Salt Cellar	France	1790
	From oblong octagonal fluted Cream Jug, with ivory handle	Russia	1808
	From pierced Fish Slice (purchased in Italy)	France	1810
	Marks used by Messrs. Boulenger	,,	1810
	Marks taken from oval Candelabra, 6 $\frac{3}{4}$ in. high	,,	1812
	Marks taken from plain Chalice	,,	1812
	Marks taken from small Altar Cruet	,,	1815
	Marks taken from round Dish Warmer, with side handles ..	,,	1816
	Marks taken from round plain domed cover Entrée Dish ..	,,	1816
	Marks taken from Casserole Dish and Cover, upright handle and engraved crest.	,,	1816
	Marks taken from plain, oval, squat, 3-gill Teapot, Fruit Dish, also Entrée Dish with florid mounts.	,,	1818
	Marks taken from florid border chased Tray, and a Sugar Basin with silver edges.	,,	1818
	Marks taken from fluted Wine Cooler with mask supports, also a wire-work Coaster.	,,	1820
	Marks taken from a plain egg-shaped 3-gill Teapot	,,	1820
	Marks taken from a round Dish and Cover, with warmer heated by charcoal.	,,	1820
	Marks taken from base of a round Dish, with cover and warmer	,,	1820
	Marks taken from base of Kettle and Stand	,,	1820

Maker's Mark.	Description of Article from which Marks are taken.	Where manufactured.	Approximate date of manufacture.
	Marks taken from small Samovar, maker's name Charkoff ..	Russia	1820
	Marks taken from 22-in. plain Tray, maker's name Petz ..	,,	1825
	Marks taken from a 26-in. plain Tray, gadroon mounts ..	? Austria	1825
	Marks taken from an 11-in. circular Meat Plate, with silver filled border and threaded edge.	France	1825
	Marks taken from Tray	,,	1825
	Marks taken from a small plain Wine Cooler	,,	1825
	Marks taken from Coasters, with shaped ornate mounts (portion of one mark not decipherable)	?	1825
	Marks taken from a large plain Wine Cooler	France	1828
	Marks taken from Service of Dish Covers, with fluted bodies and handles in the form of an Eagle.*	,,	1830
	Marks taken from a plain 2-gill Kettle (purchased in Italy) ..	?	1835
	Mark from base of oval Pie Dish, with floral border, 16 in. long, 11 3/4 in. wide, 3 in. deep.	?	1843

* Rocher of Rue de Sèvres is a present day descendant of this firm, "Durand."

PART VIII.

ADVICE TO COLLECTORS.—DESIGNERS.

HOW TO JUDGE OLD SHEFFIELD PLATE.

One of the chief difficulties to contend with in judging Old Sheffield Plate is that so much has at one time or another been replated and by constant use has toned down, again thereby greatly resembling its original appearance. Pieces that were tinned at the back and showed the least signs of copper at the time that electro-plating became general were usually sent off to undergo the new process of renovation, and when the articles are not actually ruined by this restoration it is extremely difficult to say whether they were made before the invention of plating on both sides of the ingot or not. The ultimate decision as to the age and intrinsic value has to depend, more or less, on colour tests, texture, appearances, or to some extent on the style of the period to which an article must have belonged.*

Experienced men, accustomed to handling all kinds of plated goods, can usually recognise Old Sheffield Plate almost at a glance or by touch. Fused silver plate is harder than plate produced by the process of electro deposition for three reasons. The first is the effect of the alloy ; the second, the rolling and hammering to which it was subjected ; and the third is that the electro-plating process seems to have a softening effect on the foundation metal. There is also a difference in the colour. Pure silver is always white, whilst standard silver used in the old process, has a distinct bluish cast on account of the alloy.

* In the local Directory of the year 1849, Messrs. H. D. Wilkinson advertise for articles requiring to be replated; and also in the 1852 Directory, Messrs. Walker & Co., of 11, Howard Street, advertise that the "public can have their household articles re-plated at one third their original cost."

REPRODUCTIONS OR "FAKES."

Touching the question of Old Sheffield reproductions and the enormous number of such articles that are put on the market to-day, the matter is an entirely simple one from the purchaser's point of view. The retailer has undoubtedly bought these articles from factories for making such wares, situated in London, Birmingham or on the Continent. It may here be stated that the temptation offered by the very great demand for faked pieces of Old Sheffield Plate has not, so far, led to the establishment of an electroplated on copper factory in Sheffield. Let collectors buy such articles as they select on the understanding that if they turn out to be reproductions the vendor consents to take them back, and refund the amount of the purchase money. If the question put by the would-be buyer to the seller as to the genuineness of the article under discussion be answered in an evasive manner, the idea of purchase had better be dismissed at once. Should the collector, however, trust his own knowledge and be willing to pit his brains and experience against those of the dealer, he has only himself to blame if he is taken in over a bargain and should profit by his experience without complaint. Let us presume that he has entered the shop with the idea of purchasing something at less than its value; if he finds that the contrary has resulted and then attempts to repudiate the bargain, he is certainly behaving in an unsportsmanlike manner, unless he would have been prepared to recoup the dealer for any mistake made to the dealer's disadvantage. In the purchase of antique articles the novice should constantly bear in mind the motto, "caveat emptor."

A would-be purchaser of Old Sheffield Plate would do well to be guided by the following advice when tempted to add to his collections of specimens:—

Avoid articles of either medium or large size that have no indication of a silver shield for engraving, unless sufficiently expert in periods and workmanship to identify them as being made previous to the year 1789. Also avoid articles the mounts and borders of which are made of copper, and are adapted from designs of the period when silver mounting was in vogue.

Altogether refrain from purchasing any articles of rough workmanship or otherwise badly made, mounted and finished, or that have a suspicious dull looking, charcoal-like appearance on their under sides. Finally, above all things, avoid all ill-shapen specimens and those which show badly defined detail in the execution of the stamping of the mounts and borders. To-day the reproducers of Old Sheffield Plate usually employ inexperienced workmen in the cutting of their dies.

HOW REPRODUCTIONS MAY BE DETECTED.

Reproductions may be roughly divided into several classes. First, those that are made in Sheffield entirely in the old way, from fused plate with silver shields and mounts, and with silver threaded edges. The expense is so great in making these that they have to be sold at about the same price as antique articles, and naturally they lack that mellowness of appearance, given by age, which is the best test of antiquity. The next reproductions are those made in Birmingham, selected and resurrected from designs and dies still extant, which were fashioned when the trade had got to its decadent period in that city, about the years 1820—1830. These usually bear mounts of a florid or semi-florid description and, to a genuine art collector, are unattractive in their grotesque shapes—notably so when found in the forms of large trays, candlesticks, and candelabra. The candlesticks usually have ill-assorted out-of-proportion pillars, bases and stems and highly ornate acanthus and other pattern filled mounts (the details badly defined) soldered on as an ornamentation and occasionally stamped out of thin silver. Then they are deposited whole in the electro-plating vat and afterwards finished off in a dull form without burnishing, in order to increase the resemblance to Old Sheffield Plate.

Let us now take the reproductions made in London. These are more difficult to detect, being altogether electro-plated and afterwards finished in a dark, half-oxydised colour without being burnished, while on the bases the copper is here and there left exposed to view. Some are fashioned after the designs of the earliest period—candlesticks, coffee pots, inkstands, and salvers, etc. Being adaptations from a period before the invention of plated wire and the introduction of silver-threaded edges and mounts, they are the more likely to deceive. But the purchaser should look very carefully and try to trace with a magnifying glass any tiny holes the surface may show. These are invariably associated with the process of casting, a method entirely foreign to the manufacture of Old Sheffield Plate. Casting was never resorted to by the makers of Old Sheffield Plate except in the initial stages of producing the ingot before the process of plating was undertaken.

The foreign wares reproduced to-day in imitation of Old Sheffield Plate are chiefly pierced and ornamented bottle stands, plain tea caddies and various other small articles, all electro-plated, the supply of which is increasing from year to year. Quite recently consignments of goods which had silver threads soft soldered to electro-plated copper bodies were offered for sale throughout the country. These articles had the words "SILVER EDGES"

stamped on the bizzles of the lids, as is very occasionally the case with genuine old specimens, and they found a very ready market amongst the so-called curio shops in small out-of-the-way country towns. There are always little details that arouse suspicion when such pieces are subjected to careful examination. The sides are uneven from not being properly flat-hammered and, where the copper is bare on the bases, signs of the articles having undergone the "antiquing" process are most apparent. The complete absence of original finish has left the surface in a scratchy condition, the bodies of the articles in the case of caddies and other similar goods are out of line and the knobs and feet have not been selected with due regard to the period to which they pretend to belong.

Wire-work dessert and cake baskets are popular subjects for reproduction in all their different styles and are made by the cartload by all manufacturers who copy the designs of Old Sheffield plated wares. Here, again, the makers are not sufficiently expert to produce the many kinds of shaped wires to be found on the old plated patterns, nor the very delicate varieties of both plain and gadroon mountings. The members are not so neatly soldered together and all the articles, when subjected to a close examination, bear distinct evidence of the use of the file in their production.

Articles belonging to what may be correctly described as the transitional period in Old Sheffield Plate were made between the years 1830 and 1840, when German silver was gradually superseding copper as the foundation metal for fused plate and the process of electro-plating had not yet been discovered. These pieces have often puzzled collectors, since they bear all the attributes of fused plated articles, including silver mounts and edges, etc. The foundation metal more generally in use about the year 1837 was described in catalogues as argentine. The affixing of thin silver mounts lingered on until the year 1862.

All classes of reproductions, excepting those made entirely in the old way, have a distinctly shoddy appearance after having been subjected for a time to everyday wear. This is principally due to the omission of the process of burnishing. Such burnishing, though essential to the all-round finish of a well-made plated article, is carefully avoided in all reproductions of Old Sheffield Plate on account of the tell-tale appearance of newness which it imparts.

Three specimens which may be aptly described as "Fakes" are here illustrated.



Old Sheffield "Fake" intended by its rough manufacture to imitate a piece of the earliest period ; but the workmanship of the period imitated was never as rough as this. The piece is hand made, badly fitted and chased, with a cast metal gadroon mount and cast feet, the whole electro-plated, and the plating subsequently rubbed off to imitate genuine wear.

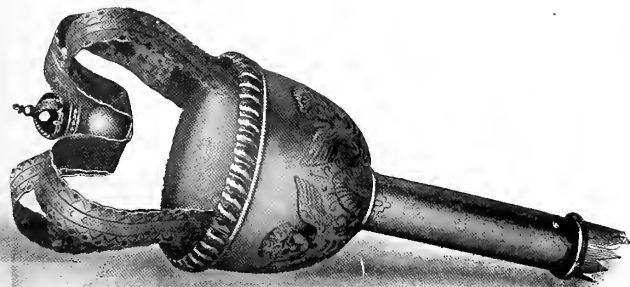

Old Sheffield "Fake" in the form of a Mace of an imaginary model, hand chased, cast gadroon mount and electro-plated throughout. In this is fitted an old rotten broken piece of wood to imitate a staff, the more readily to deceive the purchaser.



Old Sheffield "Fake" small Tea Caddy, not properly proportioned, hammered or finished, electro-plated and fitted with clumsy silver edges badly put on. On the bizzle of the lid is stamped (intentionally nearly obliterated) "SILVER EDGES."

A rather good test of the genuineness of old plated goods bearing hinges is a careful examination of the fittings of their joints. An old-time looseness consequent on the continual use of such articles is, unless they have undergone subsequent repairs, invariably to be noticed.

Lastly, a test is here given that if carried out with care is a pretty safe guide to the genuineness or otherwise of Old Sheffield Plate. As mentioned previously, the silver coating fused on to the copper sheets was a fixed standard of .925 parts silver to .075 parts copper alloy. In the case of electro deposition the silver is always pure. Apply to the article to be tested nitric acid slightly mixed with pure water, judgment being used not to leave on the acid long enough to penetrate to the foundation metal. A moment will suffice to dissolve the silver slightly on the surface. Put the distilled portion into a wine glass and add a few drops of ammonia. Should the mixture show a distinct blue colour, this will indicate the presence of alloyed or standard silver (mixed with copper). Should the colour be clear, it may be taken for granted that the silver is pure and therefore deposited by the process of electro-plating.

The author, when searching for specimens of Old Sheffield Plate recently in one of the largest curio shops in this country, discovered only one absolutely genuine article amongst hundreds of reproductions. The proprietor advanced in justification the plea that he could not get the public to pay the value or market price of genuine pieces. All his customers were apparently hunting for bargains.

It may be well here to remind collectors of Old Sheffield Plate that they need not be unduly downcast by failure to judge correctly in choosing specimens; a mental record of past mistakes is the best safeguard against their repetition. For the novice, the best advice is:—buy from a respectable firm and pay the market price.

ON RENOVATION.

In cases where the lead is showing badly through the mounts, it is unwise to resort to electro-plating. Better by far let well alone. The successful restoration of a badly-damaged article of the heavy silver mounted period requires specially careful treatment. The patching, piecing and soldering must be executed with real skill if the renovation is not to be noticeable; but it is often found that the more brilliant the article appears after its

renovation, the better satisfied is the owner that value has been duly received. Where small pieces of new mounts are required on waiters, thumb bits to mustard pots, sockets to much worn teapots, hinges to tea caddies, knobs and handles to various small articles and feet to salt cellars, etc., it is strongly recommended that standard silver be used. This soon assumes the same colour in wear as the article to which it is soldered.

The most distressing repair jobs in Old Sheffield Plate which the workmen meet with are undoubtedly the teapots. The family teapot, around which gather the earliest recollections of our infancy appeals to all, and no one would dream of substituting a new article for this cherished relic of bygone times, so long as it will hold tea. As an illustration of this an instance can be given of a lady actually threatening an action-at-law against a jeweller whom she accused of substituting a new handle of different material for the wooden handle of a teapot which she had sent to him to repair, avowing that her original handle was made of some other though similar substance.

The difficulty of restoring teapots lies in the fact that the tannin appears after a time to act on the soldered joints of the vessel, and no sooner is one leak repaired than the heat caused by the soldering starts another. The amount of time spent on restoring an Old Sheffield teapot can rarely be demonstrated to the satisfaction of the owner, there being so little visible result.

As a general rule old plate can be properly restored by piecing and by the substitution in places of partly or entirely new mounts, though in many instances, when properly done, the cost of the labour required almost equals that of the original production. One must not be disappointed, too, if at first a somewhat new appearance is imparted to the article; this is unavoidable, as a piece that has been in constant use for many years must be put into strong solutions in order to clear off the accumulations of dirt. It will be found that the earliest pieces of Sheffield Plate are the most easily manipulated, on account of the absence of the thin silver edgings and the stamped and filled silver mounts.

There are some early pieces, chiefly jugs and coffee pots, that can be re-plated to advantage. In many instances, though devoid of silver, yet, owing to their toughness and strength, they are still quite sound of body and retain their shapely forms in spite of being extremely battered. After repairing the hinges, attaching new knobs and appropriate handles, re-fastening the feet, and then tinning the insides and plating the outsides (the bruises having first of all been carefully removed), they may be started

once again on an entirely new lease of life. After a few years of constant use it would be most difficult for a collector not possessing practical experience to tell to what (if any) extent of renovation such articles had been subjected.

An illustration is here given of the wearing qualities of a pair of old Sheffield plated candlesticks, made in Birmingham about 85 years since, and of a low grade quality of plating. There is not a particle of silver to be seen on either the lead ornamental leaf foliage, nozzle mounts, or copper pillars and feet, though unfortunately the illustration does not show these defects very clearly. The pattern is a typical cheap Birmingham production of the decadent period.



Specimen pair of the commonest quality 12 in. Candlesticks, showing that the silver has been worn completely away from every part of the sticks—the mounts show nothing but the mixture of lead and tin, other parts bright copper. Made in Birmingham, period

1820—1830.

A very large number of both large and small copper tea urns were made by the London copper and tin smiths contemporarily with the manufacture of Old Sheffield plate. Sometimes these urns bear a hall-marked silver shield

riveted or soldered on to the bodies, the date letter fixing the exact year in which they were produced. These, having been electro-plated in recent years, have much deceived the public on account of their resemblance in style and shape to the old Sheffield urns. They can readily be detected as a rule by having the feet, handles, and other parts riveted together instead of being soldered on, and also by the absence of the silver mounts. Some of these copper urns bear marks such as "Warranted best London manufacture." An illustration is here given of one, copied originally from an old Sheffield pattern of about the year 1815, and most probably electro-plated about half a century later.



Copper 3 quart Tea Urn, made in London, contemporaneously with Old Sheffield Plated Urns.

Date 1815.

T. L. Crow, Tiverton.

METHOD OF DEALING IN OLD SILVER AND OLD SHEFFIELD PLATE.

There is an old-time custom attached to dealing in antique silver from which Old Sheffield Plate is fortunately free; that is, the method of selling the various articles by weight. Why the practice of realizing antique silver plate by the ounce should still be adhered to is a puzzle. It is a survival from the times when silver, discarded or sold, went into the melting pot, and it might well be abandoned now. There is no valid reason why a Queen Anne porringer or a silver tea caddy made by the celebrated silversmith, Paul Lamerie, should not be sold as an article in the same way as a piece of rare china or a chair by Chippendale. The actual value of the metal alone could never be taken into consideration where old silver brings, say, ten to fifteen pounds an ounce and the melting value is not much over 1s. 6d. per ounce. In cases where valuable antique china and old masters' are brought to the hammer, it would be rather a shock to one's feelings to

hear the auctioneer ask "that the bidding might commence at so much per ounce or pound." The materials themselves are of little or no value and the same holds good of very old silver. Long exposure to the atmosphere has given it a stiffness and rigidity which greatly detract from its intrinsic value as a melting asset, and the amount of solder contained in such an article as, say, an Elizabethan three-tier salt, a Charles I. tankard or an early Georgian cake basket, further brings down the realizable melting value to a very low point. As with antique silver, so with modern. No genuine connoisseur is ever guided by the amount of metal contained in an article when tempted to add to his artistic treasures.

Quite recently in reporting the sale values of some Old Sheffield Plate, it was mentioned that a set of sauce tureens and covers brought as much money under the hammer as would correspond with the sum of 13s. 6d. per ounce if sold by weight (as they would have been if silver). But why draw such a comparison? Surely this per ounce selling of silver is a clumsy and tiresome method of dealing with antique pieces, the abolition of which to-day would be welcomed alike by auctioneer, dealer and public. There is, too, the novice who appears from time to time in the auction room and purchases, in the teeth of strong opposition, a piece of antique silver for, say, 25s., as he or she thinks, never imagining that the article itself is being disposed of per ounce and that when the bill is presented, the cost will be found to be perhaps ten times that amount. There can be no appeal from the invoice, the conditions of sale having been, as the auctioneer will state, "fully advertised."

SALE ROOM VALUES OF OLD SHEFFIELD PLATE.

The value of Old Sheffield Plate varies according to the condition and quality of the specimens, and the range from the lowest to the highest is considerable. Articles of which only a few were made are in great request, whereas some of those more frequently met with can be bought fairly cheap. Articles that can be put into daily use for the household generally are in great demand, but pieces in bad condition of whatever period are not wanted. Well preserved pieces of the earlier period generally fetch the best prices, and a few of the articles which have gone out of use are very valuable. Much depends upon the condition of the plating. The heavily mounted, finely made, and floridly decorated later specimens in good preservation are also extremely popular. The great bulk

of that which remains in existence bears evidence of careless treatment and specimens are rare where the silver is not worn off sharp and projecting edges. A considerable quantity of Old Sheffield Plate has been sold in the auction rooms in recent years. A few particulars from the records of these will be useful in estimating the value of the ware. Prices, however, have risen since the information was collected, although at the present time the value of some articles is slightly lower.

Sauce tureens and covers shaped like soup tureens in miniature are in great request, and have realised from £5 to £15 the pair. Entrée dishes fetch good prices, sets of four selling from £16 to £50, and pairs from £5 to £25, whilst almost any sum may be paid for sets with warmers complete, in good style and condition, with the heavy mounts intact. Dish covers are not in great demand, many having been sold at less than the makers' cost price, from £9 to £14 for sets of five, though latterly their value has increased. There is a good demand for vegetable and breakfast dishes with covers, sets of four having realised from £12 to £29, and pairs from £4 10s. to £8. Sets of 24 soup plates have fetched from £13 to £16. Trays and waiters were largely produced in both plain and ornamental patterns, and a considerable proportion of them are in good condition. There is a demand for them at high prices. As much as £40 has been paid for a fine tea tray 24 inches long, with gadrooned foliage and shell border. Other records of sales of trays are:—30-inch tray, with chased centre and scroll border, £15; 24-inch waiter, plain, with shell and scroll border, £21; engraved circular waiter, 22 inches diameter, with gadroon border, £18; 22-inch plain waiter, with festoon border, £16; oblong tray, 25 inches long, with chased centre and vine wreath border, £20; other salvers and waiters from £2 to £16, according to size and condition. Of late Epergnes have been much in request. Perfect specimens of the wire-work and heavily decorated kind have brought from £30 to £40.

Other auction records are as follows:—Venison dishes and covers from £5 to £15; cake and bread baskets, from £3 to £15; wine coolers and ice pails with loose linings, pairs up to £25, and very fine samples as much as £50 per pair; teapots (plentiful), £2 to £5; tea urns, £3 to £20; coffee pots, £2 to £5; tea and coffee services, £5 to £20; snuffers and trays, £1 to £3; taper holders, £1 to £2 15s. As candles were the principal means of domestic illumination in the days of Old Sheffield Plate, candlesticks and candelabra were produced in great quantity and are still plentiful.

Oval and square based candlesticks fetch higher figures than round ones. The sale records show the following results :—Chamber candlesticks, 17s. 6d. to 8os. the pair ; candelabra, sets of three, £12 to £30 ; pairs, £12 to £20, whilst extra fine and large examples have occasionally brought as much as £50 per pair ; table candlesticks, sets of four, £2 to £21 ; pairs from 3os. to £8. The earlier specimens of square-based candlesticks of the best period, from 1770, in fine condition, have brought as much as from £10 to £12 per pair. Considerable prices are paid for small decanter stands with wood bottoms. The sides of some of these are ornamented in almost every conceivable manner, the versatility in design of decoration, both on the mounts and bodies, being quite extraordinary. Cake baskets, unless finely pierced or handsomely decorated, in bold relief, are not very popular. Cruet and liquor frames are not in request, but small soy frames of the Adam period are much sought after. Pierced (potato or) dish rings in fine preservation bring an enormous price in comparison with their original cost, as much as £20 to £30 having been paid recently for specimens in perfect condition. Pierced salt cellars, mustard pots, and sugar baskets in perfect preservation have latterly advanced greatly in price. Their value to-day may be estimated roughly as about half that of contemporary silver specimens.

APPROXIMATE DATES OF VARIOUS ARTICLES MADE IN OLD SHEFFIELD
AND ELECTRO-PLATE.

For the first seven years after the discovery of the process (in the year 1743) nothing much was attempted in the way of novelty. First buttons, then snuff boxes and other trifling articles were made. From 1750 to 1760 many very clever copies of the silver patterns then in vogue can be traced, such as coffee pots, jugs, salvers and candlesticks.* Very few of these survivals bear traces of the workmanship of tin and copper smith braziers, whose services, there is some reason to believe, were enlisted in the early days of the industry. No originality in design was introduced until the year 1760, from which date until 1770 a vast number of candlesticks were fashioned, inspiration being derived mainly from the five orders of architecture. From 1770 to 1785 the Adam and Flaxman subjects were largely adapted for candlesticks, and probably no finer conceptions were ever executed, before or since, either in plate or silver ware. The new forms were at first grafted on to or intermingled with the 5 orders, but designs of distinct and original individuality were eventually evolved. These have ever since been associated

* The shell pattern and gadroon pattern were the first introduced (see illustration, page 33.)

with the trade of Sheffield in the production of candlesticks. In the year 1770 the process of piercing and engraving was extensively introduced in a most original manner* and this in different forms still obtains. From 1785 a marked all-round advance was made in original design; silver edges had been introduced and bright cut engraving soon followed. Teapots were made, with stands to match, with engraved bands. It is found that teapots having ball feet attached were not introduced before the year 1800, either in silver or Old Sheffield Plate; after the introduction of ball feet the teapot stands gradually disappeared, the feet acting as non-conductors. Salvers and trays without handles were copied from contemporary silver, all being neatly engraved and heavily plated, usually on one side of the metal only. From 1790 to 1800 we have the introduction of the oval form into almost everything made both in plate and silver. Telescopic candlesticks and candelabra were first patented by Eckhardt and Morton in the year 1797, and by Samuel Roberts in 1798. Mention should be made of the introduction, from 1790 to 1800, of interlaced wire-work patterns of sugar basins, fruit dishes and cake baskets, both with and without handles, similar in construction to some recently brought to light at the Cutlers' Hall, the property of the Sheffield Cutlers' Company.† These were most likely made either by Samuel Kirkby & Co. or Richard Morton & Co.

These articles are amongst those most sought after by connoisseurs. They mark an originality in inventive design almost entirely peculiar to the Sheffield Plate and Sheffield Silver industry at this time, though it is worthy of notice that very similar designs were being executed by Wedgwood and other potters in cream-coloured ware during the same period.

From 1805 to 1815 shells, dolphins, and oak leaves, etc., were interspersed with the gadroons as a form of mounting. From 1815 to 1825 the designs ran riot in the introduction of variations of these gadroon and shell borders; then followed adaptations of fruit and flowers, bouquets, vine leaves and grapes, etc., the wine coolers, trays and épergnes of this period being mounted in high relief in a most extraordinary manner.‡ From 1830 to 1840 heavy ornamentation showed signs of giving way to arabesque and lengthened scroll mounts, which, with an occasional leaf or flower as a terminal, finally supplanted almost all other forms of florid ornament. Such

* See pages 118, 119.

† See illustration, page 210.

‡ Between the years 1820 and 1835 were manufactured perhaps the largest articles ever attempted in Sheffield Plate, and from the point of workmanship possibly the cleverest. These comprised interchangeable Candelabra and Epergnes with Plateaux, huge Dish Covers and Venison Dishes, Tea Urns, the Warwick Vase, and large Coffee Trays.

were the fashions in vogue at the time of the general introduction of the process of electro-plating on to German silver, about the years 1845-50. These quickly gave way to an entirely different class of goods. There then arose extraordinary varieties of *épergnes*, formed of palms, tropical plants, etc., under which reposed cattle, birds, camels, and Arab horsemen, and the tea and coffee services were eagerly purchased by the public when loaded either with heavy chasing or intricate engraving, the trays being made to match both styles. These designs continued to be popular with but little variation down to about the jubilee year, 1887. Since that time a more artistic taste has gained ground and at present there is no sign of a retrograde movement.

DESIGNERS AND THEIR INFLUENCE IN THE DESIGNS OF OLD SHEFFIELD PLATE.

Were it possible to conceive that any one man could have designed one half even of the candlesticks illustrated in this volume, his name would have been handed down to posterity with those of Adam, Chippendale, Flaxman, Lamerie, etc., but the Old Sheffield Plate trade has embraced in its 100 years of existence an enormous number of different styles, bewildering in their variety and ramifications. Hence the impossibility of an accurate division into periods with clearly fixed dates such as can be made in the case of antique silver. Old Sheffield Plate collectors may be more largely guided in fixing dates by distinct successive improvements in workmanship than by the resemblance to the designs of the periods that the articles themselves suggest. Sir Francis Chantrey's aid was called in to design the figures for the interchangeable *épergne* and candelabra illustrated on pages 240 and 241, in the early 19th century, for Gainsford & Nicholson. In 1822 Roberts & Cadman produced an *épergne* with a female figure support illustrated on page 294. About the year 1825, following on the discovery of the method then introduced for doing away with the silver threaded edges, a fashion set in for reproducing the rococo designs so popular in silver between the years 1750-1765 (see illustration of sauce boats, page 85, also tureen in centre of page 330).

PAUL LAMERIE'S DESIGNS.

Fine specimens of pierced cake baskets are to be met with manufactured in Old Sheffield Plate about the year 1765, copied in part from silver designs executed by Paul Lamerie some twenty-five years earlier; but though their general style of decoration is well maintained as regards the handles and mounts, yet the piercing, owing to the different mode of manufacture,

is neither so bold nor so free as in the case of the silver originals. Pierced silver articles in the form of small dishes have been found as early as Charles the First's time.

Paul Lamerie may safely rank as a silversmith with Chippendale as a cabinet maker, Adam as an architect, or Wedgwood as a potter, so original were his conceptions and so magnificently was his work executed. It is not surprising, therefore, that the Sheffield platers took great inspiration from his handiwork, and it is exceedingly interesting to trace the effects of his influence in the productions of the old Sheffield manufacturers through all the changes in design and workmanship that affected their industry.



Silver Tea Caddy, made by Paul Lamerie, hall marked in London in the year 1751, showing the Rococo style of ornamentation of this period. The decorative design on the outside of the caddy is well executed, but the shape of the article itself is by no means so pleasing.

Date 1751.

Page, Keen & Page,
Plymouth.



Sheffield plated specimen Caddy, some 15 years later than that made by Paul Lamerie, executed entirely by the aid of dies. It will be noted how greatly the shape of the caddy is improved by the aid of the die. Being more graceful in outline it is also much sharper in definition.

Date 1766.

Author.

In the absence of exact data it can only be said generally that Paul Lamerie was born before the accession of William and Mary. He is found entered as a silversmith at the London Goldsmiths' Hall in the year 1712. His career as a silversmith was in its zenith in George the Second's reign; it ended about the same time as Chippendale's, in 1751. Some of his latest productions bear the hall mark of that year. Did Chippendale take any inspiration from Paul Lamerie? Certainly no sideboards or tables would ever harmonise better with Lamerie's productions than those executed by

Chippendale and herein one might find much food for reflection. Be that as it may, if Paul Lamerie was not the first silversmith to introduce the piercing of silver ware on a large scale, he certainly brought these openwork designs in silver to very great perfection.

Credit must be given, however, to the Sheffield platers for much originality in the production of their form of pierced work (possibly founded on Lamerie's designs) and also for the use they made of steel dies to effect improvements in general structural design.

At one time, in the Adam period, use must have been made of Sir William Hamilton's book on *Antique Classical Figures*, which had given great inspiration to the prominent artist potters of the later 18th century. Undoubtedly, from 1800 and onwards, Sheffield originated and set the fashion for a different style of mounting to the stereotyped gadroons, scrolls, beads and ogees, which had been in constant use for decorative purposes for a century previously. More floral patterns were now being introduced in plate, and the London silversmiths of that period were compelled to follow these vagaries of the Sheffield houses. At this period, too, the potters of the Staffordshire district and the makers of china generally also adopted these styles, whilst the designs of some of the china manufactured by the local Rockingham works seem in many instances to have been copied bodily from Old Sheffield articles of the gadroon and shell (a combined form of mounting) and other patterns made between the years 1815 and 1830.

It is somewhat curious that the Sheffield plate manufacturer should have never taken more than passing notice of the "Queen Anne" period in his study of designs. Very few articles are to be found in Old Sheffield Plate that bear more than a faint resemblance to the hexagonal, octagonal, pentagonal and other plain shapes of the silversmiths' work of her period. One occasionally finds an odd chased porringer or so in Old Sheffield Plate* and a few mugs or beakers with straight sides, but the silver originals which they copied were made long after her death, as well as during her lifetime. Of the scores of silver flat-topped tankards made during Queen Anne's reign, not one genuine replica has been met with in Old Sheffield Plate. As a rule it will be found that the old makers, with the aid of their steel dies, preferred adaptation from some study of the antique in its more decorative form, as this gave greater scope for their highly trained mounters, braziers, pierce-workers and die sinkers.

* See illustration on page 349.

Amongst the very many articles copied from silver productions the Sheffield platers do not appear to have reproduced the large silver Monteith and other bowls so prevalent in the 16th and 17th centuries. Careful search through the series of Old Sheffield Plate catalogues has failed to bring to light anything more than the generally plain and oval design punch bowl of a somewhat shallow shape, around which the edges have been scalloped out to hold the wine glasses in an inverted position, such as is here illustrated.



Monteith, or Wine Glass Cooler, showing the correct position for glasses. This bowl has been gilt by the process known as mercurial or fire gilding (see page 71) and chased by hand, by Roberts, Cadman & Co.

Date 1795.

Mr. W. Willson, Richmond.

The majority of the early candlesticks when found in silver bear the imprint of Winter's, Law's, Tudor & Leader's, and Fenton's punches. They were struck from the same dies as those used for Sheffield Plate, except when made for the London market, in which case they usually bear the mark of some London silversmith. It should be noted by collectors of antique silver that although these die-struck 12-inch candlesticks are much sought after by connoisseurs as London specimens, bearing the London hall mark, there was not at that period, 1765-1850, a firm of "die-striking"

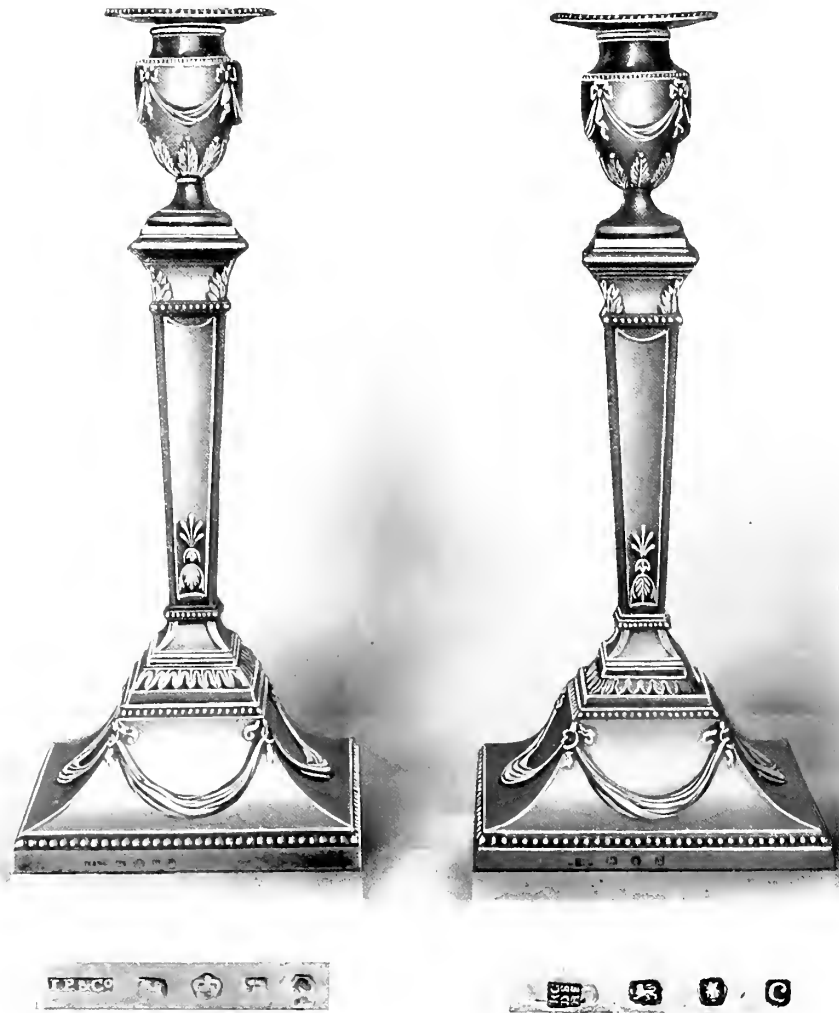

Pair of 12 in. Candlesticks, in silver, manufactured in Sheffield by J. Parsons & Co., one stick is overmarked by a London silversmith with his firm's punch.*
 Dates 1786 and 1778. Author.

candlestick makers working in the Metropolis, this being a branch of the industry that even to this day remains almost entirely peculiar to Sheffield. In proof of this assertion there is illustrated here a pair of Adam pattern silver candlesticks both made from the same dies: one stick is marked with J. Parson's punch and halled in Sheffield, 1786; the other shows signs of being obviously, at some time or another, overmarked by "Richard Carter, Danl. Smith, and Robert Sharp," of London, in the year

* Other instances can be given of this overmarking of Sheffield assayed candlesticks by the London Goldsmiths.

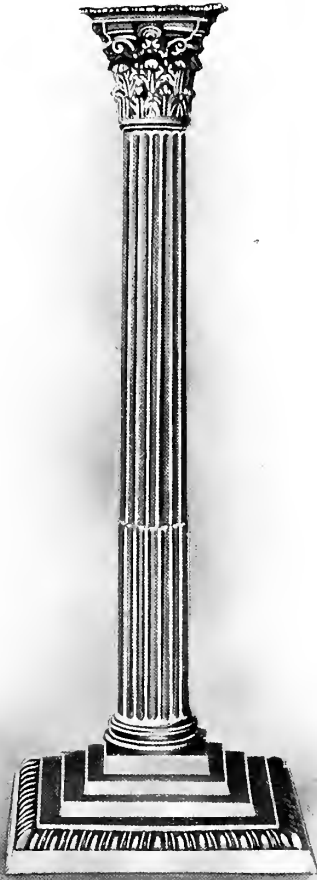

London made Candlestick, in silver,
cast and chased, 13 $\frac{1}{4}$ in. high.
Date 1765. Chapple & Mantell.

1778. The cast and chased London-made silver candlestick here illustrated, of the date 1765 and 13 $\frac{1}{4}$ inches high, with its pillar out of proportion to the size of the foot, bears no comparison with any of the fine specimens of Winter's make in Sheffield about the same date.

CHIPPENDALE'S INFLUENCE IN DESIGN.

With regard to the many original designs in wine coolers, the conclusion is drawn that the enormous collection of finely chiselled vases from the Vatican in Rome was the most fruitful source of their origin; whilst as for the old heavily-mounted trays and épergnes, they bear tolerably conclusive evidence of copy from Chippendale's handiwork. As is well-known, he was an exquisite carver, and, where he could, and the subject was capable of being so treated, he preferred to load his work with this heavy rococo ornament. The Sheffield Plate manufacturer would design his

wine coolers, trays and tea urns, as far as possible in sympathy with the sideboards on which they were destined to stand* and Chippendale is credited with having lent his genius for design in other practical forms to the Sheffield plate manufacturers, though careful search has not at present brought to light any definite information on this interesting subject. Chippendale's career was drawing to a close about the time that Sheffield Plate began to make headway. The dates both of his birth and death are even to this day shrouded in mystery. All that we know definitely with regard to him concerns the publication of his book of designs, which went through three editions,

* The firm of T. Bradbury & Sons still possess dies the original of which have been attributed to Chippendale himself.

the last of these being published in the year 1762. Some of the plates are dated 1753 and 1759. He had a son, also Thomas Chippendale, who succeeded him in his business. The claw and ball foot so extensively used by silversmiths and plate manufacturers was adapted from Thomas Chippendale's designs; but to show the obscurity of the origin of this attractive little piece of ornamentation, it should be said that Chippendale took it from the French designer, the latter having copied it from the Dutch, who are reported to have introduced it from China, where it had been in use for nearly two thousand years.

Possibly the latter day revival of interest in Chippendale's workmanship is to some extent enhanced by the mystery associated with the beginning and end of his career. In all the antique shops we enter, north, south, east or west, we are informed that almost everything is "Chippendale," his design, style or period; and if we fail to be enthusiastic about articles thus described to us, a happy inspiration seizes the dealer, and he tries the magic words "Queen Anne." Surely, if these two distinguished people could be aware of what is now ascribed to themselves and their period, the stolid satisfaction on the homely features of England's last Stuart Sovereign would be exchanged for an expression of pained surprise; while the "master cabinet maker," if he had any feelings of self-esteem, would be cut to the quick by the sight of the appallingly grotesque articles persistently associated with his handiwork or described as taken from his designs.

THE ADAM PERIOD, AND THE POTTERS NAMED ADAMS.

Another complication that the collector of antiques has to face is the Adam period (which, it is scarcely necessary here to explain, is unconnected with the earliest history of mankind in any shape or form). Its effect on the contemporary Old Sheffield Plate was so great that it is necessary to mention it *en passant*. Robert Adam (not Adams), born in Edinbro' in 1728, was an architect, who undoubtedly derived his inspiration from his three years' residence in Italy, 1754—57, and was the most popular designer in England at the latter end of the 18th century. He died in 1792, and was buried in Westminster Abbey. Almost everything between the years 1770 and 1790 in Old Sheffield Plate shows distinct signs of his influence in design, hanging festoons, urns, rams' heads, husks, etc., etc., being worked into decoration in a most ingenious fashion.*

* In the Sir John Soane Museum, London, is to be seen a book of original illustrations, by Robert Adam, including a large number of designs for articles in silver such as vases, candlesticks, dessert dishes, tureens, cups, etc., executed between the years 1764 and 1779.



SIR F. CHANTREY, born 1781, died 1841 (a native of the Sheffield District).
From a silver medallion in the author's possession.



JOHN FLAXMAN, born 1755, died 1826.
From a silver medallion in the author's possession.



WILLIAM ADAMS, born 1777, died 1805.
One of the family of Adams the Potters. From an illustration supplied by Mr. P. W. L. Adams.



JOSIAH WEDGWOOD, born 1730, died 1795.
From an old print in the author's possession.

The Adams, the potters, lived and executed their superb jasper and other wares over much the same period (and the names are unfortunately often confused with the architect and his brother James, known as the Brothers Adam). There were four of these Adams, all working potters, between 1745 and 1865, in the Tunstall district. It was William Adams, however, 1745—1805, who executed the exquisite blue jasper and stoneware jugs with so-called Flaxman figures thereon, adapted from the ancient Grecian and Roman friezes.* Also it was he who served his apprenticeship with and was a firm friend of Josiah Wedgwood, whilst the latter (born in 1730 and dying in 1795) exercised as much influence over the china productions of his times as Chippendale did over the furniture, and Robert Adam over the interior decoration of houses and other buildings. Josiah Wedgwood was also a personal friend of both Samuel Roberts and Matthew Boulton, the latter, being more closely contemporary, did most of the mounting for him in Old Sheffield Plate and silver. Thomas Law mounted the majority of the jugs for William Adams both with Old Sheffield Plate and silver mounts; and at one time there were scores of these in existence, but unfortunately, being easily broken, there are very few to be found to-day intact outside museums and carefully preserved private collections. Ashforth, Ellis & Co. (Sheffield plate manufacturers), in the later days of the trade, opened a branch in Paris, in close connection with Wedgwood's show-room.

On the opposite page is an interesting illustration of Pickslay's Show Rooms in Sheffield. These premises were in existence in the year 1828. The following is an extract from a local Directory of that year:—"The exterior of the building may possess considerable attractions for the antiquarian, being one of the oldest fronts in the town, furnished with a most elegant and valuable selection of Sheffield Plate and silver articles of the first quality, design, and workmanship."

* See pages 339, 340.

PICKSLAY, APPLEBY, AND BERTRAM,

MANUFACTURERS

TO HIS MAJESTY AND THE ROYAL FAMILY,

THE COMMANDER-IN-CHIEF, THE LORD CHAMBERLAIN, &c. &c.

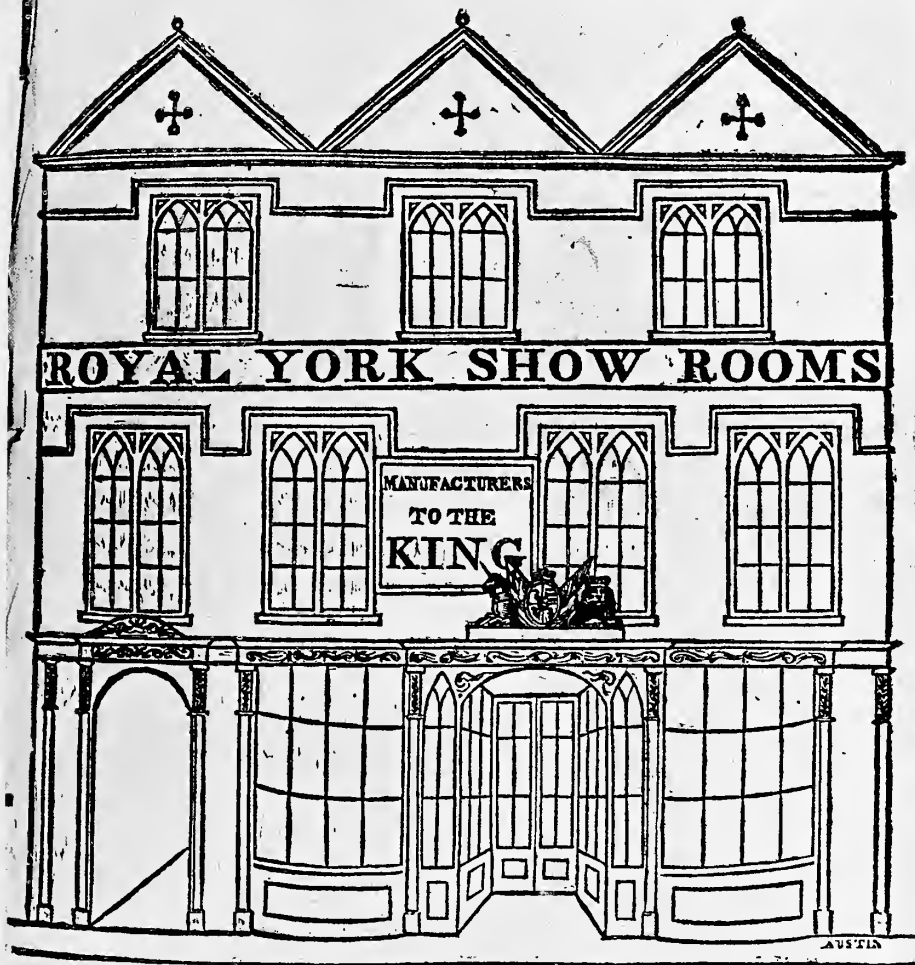

HIGH-STREET, SHEFFIELD.

The above Rooms are an Emporium of the Manufactures of Sheffield, where Strangers without trouble or expense, have an opportunity of viewing a most extensive and elegant selection of the unrivalled productions of its Artizans, in all the various branches in which they have been so long distinguished.

PART IX.

ON ASCERTAINING DATES OF SPECIMENS.

EXTRACTS FROM A DIRECTORY OF THE YEAR 1774, OF ARTICLES THAT WERE THEN MADE IN SHEFFIELD IN SILVER AND SHEFFIELD PLATE.

The following extract is from the earliest Sheffield Directory, published by J. & T. Sketchley, of Bristol and Hull, in 1774 :—

“ These ingenious workmen make a great variety of articles, an account of which, here, may not be improper, viz. : épergnes, tea urns, coffee and tea pots, tea kettles and lamps, tankards and measures of all sizes, jugs, cups, goblets, tumblers, candlesticks, branches, cruet frames, water and platter plates, and dishes, dish rims, crosses, castors, tea trays, water bottle and writing stands, tureens, ladles, spoons, scallop shells, canisters, mustard pots round and oval, salts, bottle labels, cream pails, bread and sugar baskets, argyles, snuffer stands and dishes, wine funnels, skewers, cream jugs, lemon strainers, cheese toasters, chocolate pots, sauce pans, stew ditto, snuff boxes, bridle bits, stirrups, buckles, spurs, knife and fork handles, buttons for saddles, and a great variety of other articles.”

Gales & Martin's Directory of Sheffield, published in 1787, adds to this list of articles : communion services, entrée dishes and decanter stands.

To supplement these a complete list is here given of Old Sheffield plated wares, as manufactured by Watson & Bradbury between the years 1788 and 1815, with original descriptions taken from the pattern book of the firm. During this period the trade enjoyed its greatest prosperity :—

OLD SHEFFIELD PLATE ARTICLES AS INDEXED IN AN OLD PATTERN BOOK
BETWEEN THE YEARS 1788 AND 1815.

Argyles various patterns	2	Candlesticks .. various patterns	217
Asparagus Tongs	1	Swage Top Candlesticks ..	95
Bottle Trays	105	Bracket	187
Bread Basketts	148	Branches for	324
Butter Coolers	13	Chamber	111
Bisquit Boxes	2	Shade	18
Beakers	9	Patent	182
Butter Knives	3	Wax Winders	56
Bougie Boxes	6	Cruet Frames	486
		Coffee Pots and Biggins	136

Chocolate Pots..	various patterns	1	Mugs	various patterns	4
Cannisters	7	Muffineers	8
Cream Ewers	106	Punch Ladles	4
Corks	7	Platto (Plateaux)	8
Chalices and Plates	1	Plate Warmer	1
Comfores	2	Pitchers	2
Coffee Urns	19	Pickle Frames	7
Caudee Shells	3	Spoons	21
Cups and Measures	41	Snuffer Trays	165
Cheese Toasters	8	Sugar and Creams	107
Communion Cups	2	Salt	138
Dish Crosses	4	Soy Frames	84
Dish Rings	20	Sugar Tongs	3
Dishes	42	Snuffers	13
Dish Covers	6	Soup Ladles	19
Decanter Corks	7	Segar Boxes	1
Dish Warmers	12	Sauce Ladles	11
Dish Wedges	3	Sugar Sifters	2
Epergnes	269	Salad Stands	74
Egg Frames	65	Sauce Pans	8
Egg Boilers	6	Services	1
Egg Cups	11	Sundries	83
Forks	3	Slop Bason	7
Fish Knives	20	Soup Plates	2
Fruit Basketts	103	Toast Trays	78
Flaggons	7	Tea Urns	106
Gobletts..	19	Tureens	73
Gravy Spoons	4	Tea Potts and Caddies	114
Honey Hives	1	Tea Cannisters	7
Ink Stands	70	Tea Trays	74
Ice Pails	17	Tea Bells	1
Knife Rests	4	Toasting Forks	1
Knife Trays	6	Tea Machines	3
Kettles	6	Tobacco Boxes	1
Liquor Frames..	328	Teapot Stands	10
Labels	7	Table Plates	5
Lamps	7	Tea Setts	85
Mustard Potts	65	Vinaigrettes	10
Marrow Spoon..	1	Venison Dishes	10
			Waiters	96
			Wine Tasters	1
			Wine Strainers..	31
			Water Plate	6

Collectors of Old Sheffield Plate will find the latter list of goods made by one of the earliest known fused plated manufacturing firms in the world of great interest. It is indeed fortunate that from the general wreckage and wholesale destruction through which the industry passed, to emerge eventually in another form, a few books, such as that from which this list was copied, have been preserved. For those not connected with the trade a slight explanation is perhaps necessary. The articles enumerated are only those that were made by one particular firm: naturally various manufacturers excelled in different branches of the trade. As regards the making of candlesticks and cruet frames this firm must evidently have been pre-eminent at one period. It is a surprise to find "vinaigrettes" in the list. "Comfores" were pierced or plain sweetmeat dishes, with glass linings, sometimes made of wire work, fastened to waiter plates and much resembled sugar basins with large feet. "Fish knives" were not as we understand them—fish eating knives—but fish slicers or servers without forks to match them. "Honey hives" were honey jars in the form of a bee hive. "Bougie boxes" are classed along with the wax or taper winders and answered the same purpose. "Bracket" candlesticks were a form of smaller candlestick, having derived their name from the fact that originally they were made in the form of a bracket which could be attached to the walls of a room or fixed to the side of a spinet or writing desk.

It will be noticed that no mention is made of buttons, snuff boxes or buckles. Although the first two articles were the earliest made in Old Sheffield Plate, their manufacture drifted to Birmingham. The question as to whether or not buckles were made in Sheffield has been dealt with earlier in this work.*

Two interesting records of purchases from celebrated Sheffield Plate manufacturers in the year 1821, with illustrations of the articles themselves and original receipted invoices, are given on the next page, the property of Mrs. John and the Misses Barker, of Wisewood House, Sheffield. Although nearly a century has elapsed since the goods were bought, it is of interest to find them in such good condition, and also that only one of the articles is missing.

* See page 22.

Mr Jas. Oakley Sheffield Jan 1. 1821.



D. D. & Co.
 of SHEFFIELD and PLATED ARTICLES
 Manufacturers
 1 Coffee Pot, with Silver Mounts & 2 12 0
 1 Tea Tray with 4 Silver
 1 = 3 Hold all 7 Trays, with Silver
 1 Mounting, Handle. Act to 2 14 0
 £ 7 10 0

Wm. H. D. S. M. M. M. M. M.

1 Tea Tray
 1 Coffee Pot
 1 = 3 Hold all 7 Trays
 1 Mounting, Handle
 2 12 0
 0 19 6
 2 14 0
 £ 7 10 0

Wm. H. D. S. M. M. M. M.

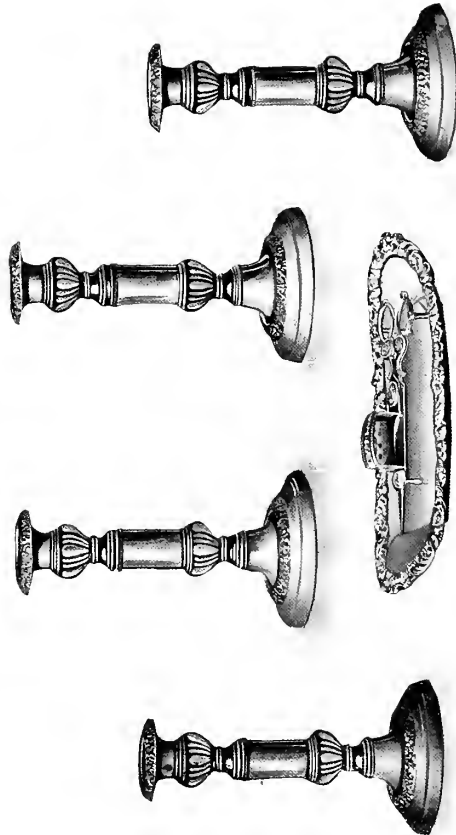
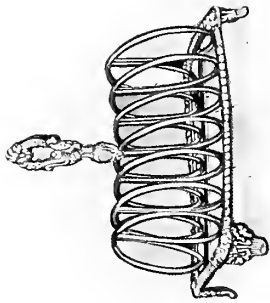
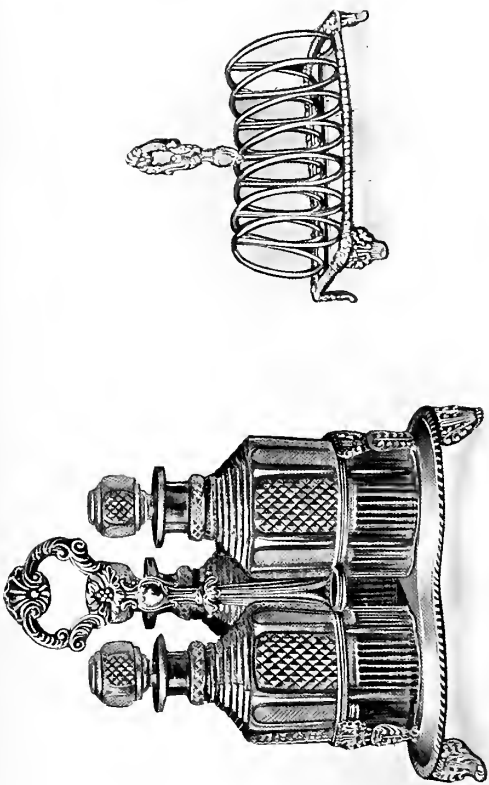

Illustrations of Old Sheffield Plated Articles purchased in the year 1821, with Original Invoices.

ILLUSTRATIONS OF ARTICLES THAT WERE MADE IN SHEFFIELD BOTH IN SILVER AND SHEFFIELD PLATE.

Where one article was made by the Sheffield manufacturers in silver, dozens were produced from the same models in fused plate. Hence certain patterns have grown to be regarded as associated particularly with Old Sheffield Plate. When, as occasionally happens, designs peculiar to the plated styles come under the hammer, composed of silver, the fact not infrequently escapes the notice of both auctioneer and public. Some years ago a pair of Sheffield Plated Trays similar to illustration at foot of page 322, but larger, were put up to auction and sold for the modest sum of £25. They were afterwards discovered to be solid silver; as they weighed nearly 400 ozs., they were worth at that time double the sum given merely for the intrinsic value of the silver.

Illustrations are given of a method of ascertaining dates of Specimens of Old Sheffield Plate and names of makers by comparison with Sheffield made silver articles.

Designs in both silver and Sheffield plate invariably portray the individuality of a maker however they may be adapted, as may be seen in illustration of salt cellar and coaster shown below; notice also the foot of the cake basket on page 210, and a pierced mustard pot on page 314.

Again refer to illustrations "138" on page 398 of a salt taken from an old plater's catalogue. Here we have an instance of four different kinds of articles carrying the same decoration and made almost entirely by the aid of the same piercing tools. The silver salt cellar hall marked in Sheffield in 1777 by M. Fenton & Co. is a guide, not only to the approximate date and the maker of the coaster, mustard pot, and basket, but also to the identity of the firm who issued the catalogue in which this salt cellar is illustrated.



Silver Salt Cellar, pierced under a fly punch, and Hall marked in Sheffield. By M. Fenton & Co. Date 1777. Author.



Old Sheffield Plated Pierced Coaster, obviously made by the same firm and in the same way as salt cellar, and about the same date. Author.



2½-pint Silver Fluted "Biggin," by T. & J. Creswick.
Date 1812, Sheffield Hall Mark. Author.

2½-pint Fluted "Biggin," in Sheffield Plate, by T. & J. Creswick.
Date 1812. Author.



8 in. Silver Chased Shell and Scroll Border Salver,
by T. & J. Settle.
Date 1827, Sheffield Hall Mark. Author.



8 in. Chased Shell and Scroll Border Salver, in Sheffield
Plate, by T. & J. Settle.
Date 1827. Author.



3-light Silver Candelabra, 24 in. high, one of a pair, weighing 210 ounces, by Roberts, Cadman & Co.
Date 1812, Sheffield Hall Mark. Mr. H. Steel, Sheffield.

The Candelabra illustrated, though made from the same dies as many Old Sheffield ones, are silver, and were purchased some years ago as "Old Sheffield" for the sum of 50s. the pair. Though this was discovered prior to their coming into the possession of the present owner, it is believed that the original possessor, if still alive, is unaware of the mistake he made when selling them. The weight of silver in the pair is 210 ounces.

ILLUSTRATIONS AND DESCRIPTIONS
OF OLD SHEFFIELD PLATED
ARTICLES, WITH THE APPROXIMATE
DATES OF THEIR MANUFACTURE
AND NAMES OF MAKERS.

A large number of specimens of Old Sheffield Plated articles are here illustrated, described and dated as accurately as possible.

As concerns the dates, descriptions, and names of makers herein given, absolute accuracy

is not pretended or claimed. Such details as are appended have been arrived at mostly by comparisons. Very great assistance in this connection has been obtained from a representative collection of Sheffield made contemporary silver in the author's possession, and an almost complete collection of Old Sheffield platers' catalogues and valuable old records and pattern books belonging to the firm of T. Bradbury & Sons.

Wherever possible the specimens have been reproduced with due regard to their dimensions, but where reliance has been placed on the kindness of individuals who have sent photographs for reproduction in this work, the size of illustrations has had, to a great extent, to be dependent on the relative proportions of the original negatives.

It will be noted how small comparatively is the number of makers' names that appear in these illustrated lists. The reasons for this are not far to seek.

In former days, much as now, a few of the leading firms overshadowed all the others, and the goods made by one-fourth of the better known manufacturers, whose names appear in the directories and elsewhere, outnumber almost by 10 to 1 the productions of what may be termed the smaller fry of the trade. Once firmly established, the tendency was for a firm to grow in size, and as the years went on and its range of patterns extended, the number of its dies would increase in proportion. Again, the makers had the bad habit of copying from each other and of marking goods for various markets with each other's devices. Possibly the same individual designed for a variety of different firms. More probably, as mentioned earlier in this work, manufacturers did not scruple to adopt suggestions derived from the productions of rivals who excelled them in originality of design. Lastly the practice of interchanging the different parts of articles, *e.g.*, the feet, pillars, and capitals of candlesticks, in order to extend the range of patterns, makes it difficult to fix accurately the date of many antique specimens of Sheffield Plate.

ARGYLES.

The Argyle gravy holder, one cannot help thinking, must have derived its name—as is supposed to have been the case with the Monteith bowl—from that of the original inventor. In the earliest books of reference connected with the Old Plate trade these articles are described as “Argyles.” They were made in various patterns. That shown to the left in the form of a teapot had a separate chamber with a detachable lid. This was for the hot water, and around it was poured the gravy. That to the right is in the form of a hot water jug with a double lining or jacket

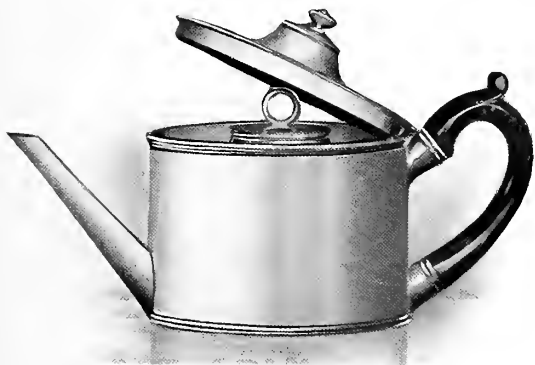

3-gill Argyle, in the form of a Teapot, by Goodman,
Gainsford & Fairbain.
Date 1795. Lambert, London.



2½-gill Argyle, in the form of a Jug, by
M. Boulton & Co., Birmingham.
Date 1800. D. & M. Davis, Birmingham.



Oval Sauce Tureen, with hot water jacket and engraved border,
silver shield soldered on separately, holding $1\frac{1}{2}$ pints,
by J. Younge & Sons.
Date 1789. Franklin & Hare, Taunton.

for this purpose. To-day the use of Argyles has almost entirely ceased.

The sauce tureen illustrated is also an ingenious invention to serve a similar purpose. The tureen is fitted with a double jacket, and at either end can be seen, on the handles, which are hollow, two small catches which, when loosened, expose a small opening down which the hot water can be poured for the purpose of keeping the sauce warm.

Should these hollow jacketed vessels, however, get bruised or become damaged in use—a not infrequent occurrence—they are extremely troublesome to put in order again.



1-pint Hot Water or Shaving Pot, by D. Holy, Parker & Co.
Date 1805. Mr. F. Hawley, London.

into which the hot water was poured down the lip that can be seen to the right, whilst the gravy was placed inside the body of the jug. The spout went right through the hot water jacket and into the body of the jug itself, and out of this spout, when tilted up, the gravy could be poured. Other Argyles there are in different forms, but all made with the same object, i.e., to keep the gravy hot during meal times, and very successful they will be found

CAKE AND FRUIT BASKETS.

Of these articles known in earlier days as "bread baskets," 148 different patterns, it will be noticed, are given in the list of articles scheduled on page 196 as made between the years 1788 and 1815. The cake baskets in their lighter and earlier form—and especially the wire-work productions—are far more popular to-day than are the heavy cumbersome productions of the late Georgian period.

The lightness of cake baskets, and also of fruit dishes and fruit baskets enhanced their value as table ornaments to an extent which



Oval pierced 13 in. Cake Basket, copied from contemporary silver pattern,
by John Hoyland.
Date 1768. Author.



Blunt oval pierced 13 in. Cake Basket, by Tudor & Leader,
Date 1778. Spink & Son, London.

can be better appreciated when they are filled for use than when they stand empty in a collection. A goodly number of patterns of these baskets were produced in Old Sheffield Plate, and the same list that contains the bread baskets also enumerates 103 different patterns of fruit baskets. The bottoms of some of the light forms of wire-work fruit baskets were most usually gilt.

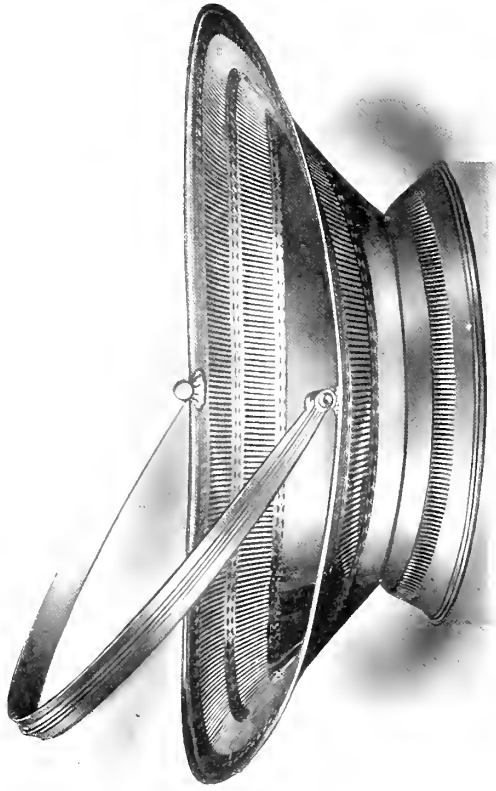

Oval pierced 14 in. Cake Basket, by Richard Morton & Co.
Date 1784.
Wilson & Sharp, Edinbro'.

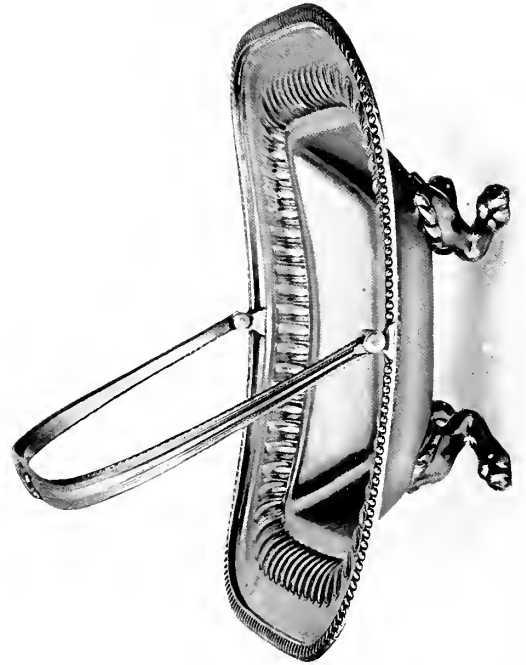

Fluted Cake Basket, 14 in. long, with claw feet supports, by
D. Holy, Parker & Co.
Date 1809.
Ford & Son, Newark.



Blunt oval 13½ in. pierced Cake Basket, by M. Fenton & Co.
Date 1779.
Miss Bradbury, Sheffield.



Oval pierced 14 in. Cake Basket, by D. Holy, Wilkinson & Co.
Date 1785.
Author.

Oval 14 in. wire work pierced and chased
Cake Basket, by Ashforth, Ellis & Co.
Date 1790. Lake & Son, Exeter.



Oval 13 in. wire work Cake Basket, with shaped top,
by S. Kirkby & Co.
Date 1795. Blackford, Lynton.

Oblong 14 in. wire work Cake Basket,
by Watson & Bradbury.
Date 1808. Coopland, Sheffield.



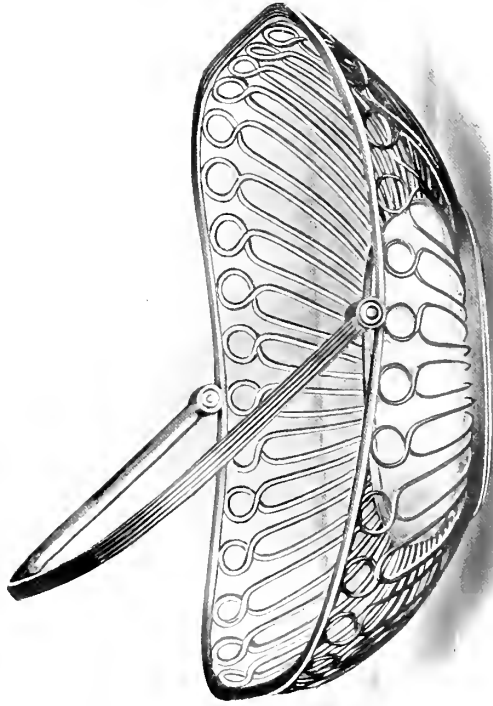

Oblong 12 in. wire work Cake Basket, by Kirkby Waterhouse & Co.
Spink & Son, London.
Date 1805.

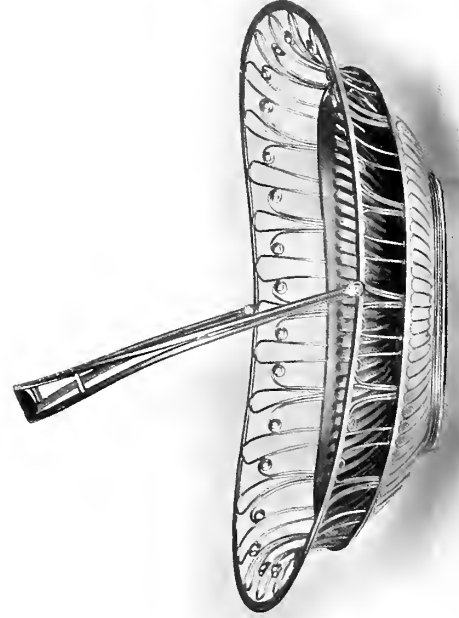

Oblong 12 in. wire work Cake Basket, by S. Kirkby & Co.
Franklin & Hare, Taunton.
Date 1801.

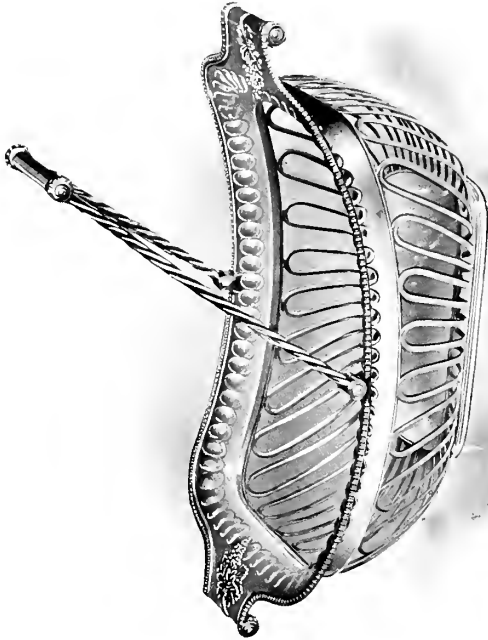

Oblong 12 in. wire work Cake Basket, gilt base, by N. Smith & Co.
D. & M. Davis, Birmingham.
Date 1807.



Oblong 10 in. wire work Cake Basket, with shell and
gadroon mount, by Kirkby Waterhouse & Co.
Lake & Son, Exeter.
Date 1816.



Oblong shaped border 12 in. Cake Basket, by Kirkby Waterhouse & Co.
Date 1816. Withers, Leicester.



13 in. Oblong Cake Basket, with florid border and chased body, by T. J. & N. Creswick.
Date 1821. F. Lyne, Bristol.



Blunt Oval 13 in. pierced and pressed festoon Cake Basket, by M. Fenton & Co.
On base is scratched 'F&C' (Fenton, Creswick & Co., see page 38).

Date 1773.

Mr. Dudley Westropp, Dublin.



Round wire work Fruit Dish, 8 $\frac{3}{4}$ in. diameter.

Date 1803.

The property of The Cutlers' Co., Sheffield.

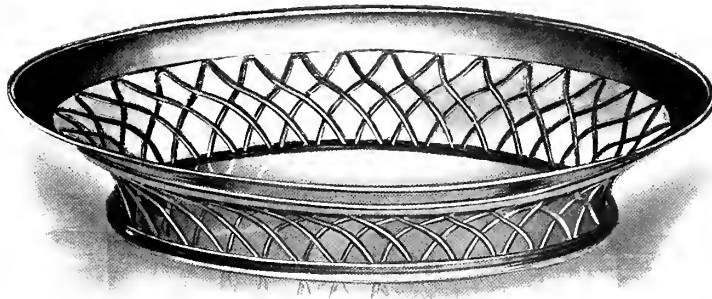

Oval wire work Fruit Dish, 11½ in. long, by Watson & Bradbury.
Date 1799. Author.



Oval pierced scroll end Fruit Dish, 16½ in. long, by R. Morton & Co.
Date 1780. Elkington & Co., London.

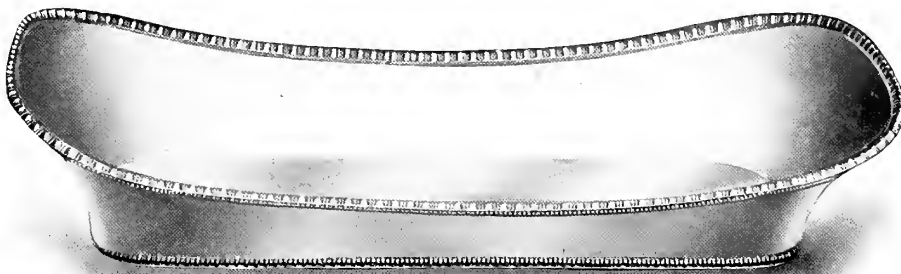

Oblong gadroon mount Bread Tray, 13½ in. long, by Watson & Bradbury.
Date 1806. Thomas & Co., London.



Oval shaped and pierced bread basket, $14\frac{3}{4} \times 9$ in., by D. Holy Wilkinson & Co.
 Date 1785. Heming & Co., London.



Preserve Dish, $8\frac{1}{4}$ in. high, with blue glass lining, by G. Ashforth & Co.
 Date 1788. Author.

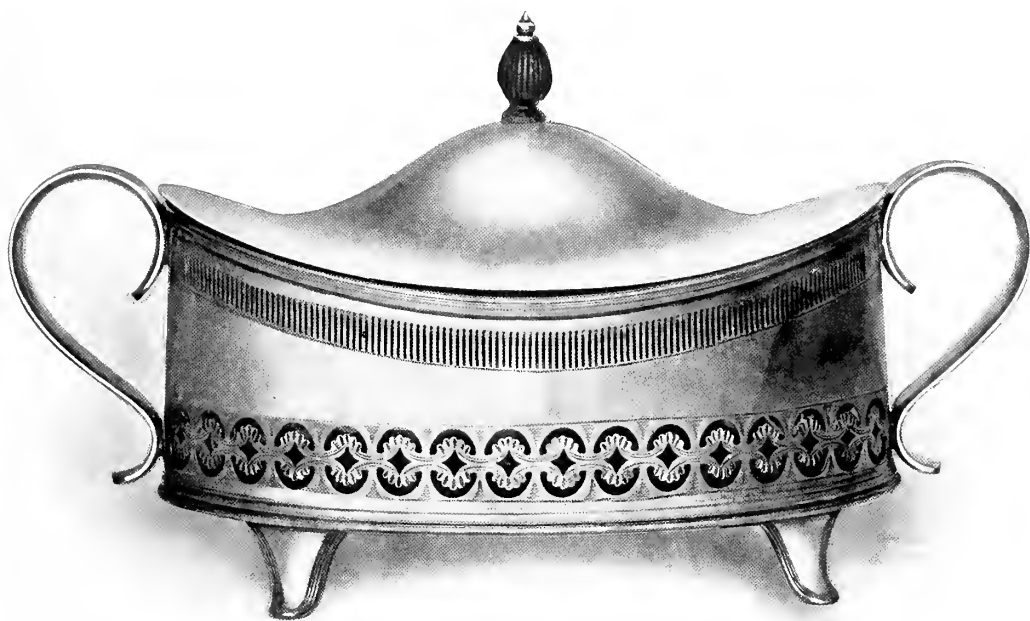

Butter Dish, 7 in. long by $4\frac{1}{2}$ in., with blue glass lining, by J. Younge & Sons.
Date 1789.

Author.





Small Sweet Dish, with swing handle, by
D. Holy, Wilkinson & Co.
Date 1786. Wood, Nottingham.



Card Tray, handle and body of "argentine" metal (see page 137).
The mounts of silver (filled), body hand saw
pierced and flat chased (electro-plated),
by T. Bradbury & Sons.
Date 1848. Miss Bradbury, Sheffield.

CANDLESTICKS.

With regard to the prominence given to candlesticks and the numbers illustrated in this book, it is well to bear in mind how indispensable to the comfort of indoor life has been the candle from the earliest times to our own. Candlesticks are mentioned in the Bible nearly 1,500 B.C. There is still in existence in this country a candlestick of the "Pricket type," formerly in the Abbey Church of St. Peter, Gloucester, the date of which has been fixed as early 12th century. Even to-day there is no softer or more restful light than that supplied by the ordinary wax candle. Those who spend many weary hours working under the fixed glare of incandescent gas or electricity appreciate as none others can the subdued brilliance imparted by candlelight, not only to the appointments of the dinner table itself, but also to the jewellery of the ladies. It is almost impossible to get equally satisfactory effects from electric light or gas, however treated.

Amongst the earliest articles made for table use by the fused plate manufacturers were candlesticks, and there are good grounds for believing that one previously illustrated on page 33, Part II., was actually made by Joseph Hancock himself, about the year 1755. It bears the initials  in characters entirely different from the lettering used by John Hoyland, a somewhat later manufacturer, whose mark was  * Also the workmanship is of the crude description distinctive of the earliest efforts of the old plate makers.

The collettes and necks, which constituted the chief parts of the earliest candlesticks, were composed of hoops soldered together and afterwards swaged into their required shapes. Consequently they fit unevenly and are disproportionately balanced on the shoulders. The feet, the shoulders and the pillars bear evidence of being struck from some rough forms of cast dies and of being subsequently chased up by hand, whilst the nozzles show signs of both hand and die work. The articles were completed by soft soldering the parts together, but the plating was generally of an extraordinary thickness.

This method of manufacture was superseded about the year 1765, by the introduction of candlesticks constructed entirely from cast dies, without the aid of swaging. They were principally made with fluted pillars and capitals, such as are to be found on Ionic columns, with innumerable varieties of bases, though the shell pattern illustrated on page 33, was never lost sight of throughout the whole of the period through which the industry survived.

* Hoyland made numbers of the earlier candlesticks on which this mark is still often to be found. In 1779 a new firm under the title of Younge, Greaves & Hoyland was founded, the successors of J. Hoyland & Co.

About the year 1800 were introduced silver gadroon, bead and other mounts stamped separately and soldered on to the shoulders and bases of plain round patterns of candlesticks, these mounts being previously filled with tin and lead. This form of mounting candlesticks continued in vogue until the termination of the industry, the mounts and borders of the sticks themselves becoming so extravagantly decorated, that the designs eventually flowed over and around the bases, stems and capitals of many of the candlesticks made between the years 1810-1825.

Some of these very ornate candlesticks will be found stamped more or less completely in thin silver and filled with tin and lead, the only parts that were made from fused plated metal being the hoops, pans and bizzles of the nozzles. These candlesticks were of course unassayed. To give some idea of the great number of candlesticks turned out by the Old Sheffield platers, a reference to the list of articles on page 196 shows that, including wax winders, brackets, chamber, patent slide candlesticks, and branches, no less than 1,190 different patterns were made by one firm during a period covering upwards of 25 years of production.

THE FILLING OF CANDLESTICKS.

The method of filling candlesticks must, we are compelled to think, have been of local origin, borrowed from the practice of stamping knife handles in halves and soldering them together. The process was carried out as follows: After placing a rod of iron up the centre of the stems, the candlesticks were turned upside down and a mixture of resin and loom was poured into the sticks in a molten liquid form. When cooled, this mixture formed a hard solid substance. The addition of the iron rod prevented the candlesticks from breaking in their more slender parts, besides adding stability and weight to the whole. When making these filled candlesticks for the foreign markets a composition was used, of which Plaster of Paris formed the chief ingredient, as resin melts in hot climates.

The object of manufacturing both plated and silver candlesticks in this way was to give a clear definition to the very delicate outlined work of the dies by having the sections struck up from very thin sheets of metal. The success attending the production of these stamped filled candlesticks was very great, as the new process ensured a great saving in labour as well as in material. This system is carried on in Sheffield to this day, having lasted continuously for over 150 years.

The great number of what are termed telescopic pattern candlesticks will be noticed by collectors of Old Sheffield Plate. Presumably the sole object was to raise or lower the candle as required. In all adjustable candle-

sticks the plan usually adopted was to fit a cloth lining inside the slides, so that when moved up or down there was no metal to metal binding, and consequently no scratching of the pillars during the sliding process. Eckhardt's Patent—which appears to have been the first taken out for telescopic candlesticks—varied from others in having adjustable brass collettes fitted as a slide, with two slits on either side which could be opened or pressed down to enable the slide to work either more easily or more stiffly as required (figs. 3 and 4).

The simplest and most efficient device was based on the Archimedian principle; the candle, fixed on a small spike in the base of the candlestick capital, could be pushed up and the height of the candlestick raised at the same time by screwing up the pillar (fig. 8). No patent mark was stamped on these candlesticks. The telescopic candelabra illustrated on page 238, which bears the imprint of **ECKHARDT'S PATENT** was a bone of much contention. £120 5s. 6d. was spent in attempts to validate this patent in the joint names of Mr. A. J. Eckhardt and Mr. Morton. A *caveat* was lodged in connection with this matter by a Mr. Warry, of Norfolk Street, Sheffield; and the claim appears eventually to have been upset on the ground that the manufacturers had sold the articles before patenting. The date of this application for Eckhardt's patent was October 15th, 1796, and the period of these telescopic sticks is from 1795 onwards, though they are rarely to be met with made after the commencement of the reign of George IV. Telescopic candlesticks working on the "notch and catch" principle (similar to fig. 2), are sometimes to be found marked **MORTONS PATENT**. In the year 1798 Roberts, Cadman & Co. secured a patent on similar lines. Telescopic candlesticks made by them are seldom found without the words **R.C.&C.'S PATENT**. Again, ordinary slide candlesticks are to be found working on the same cloth-lined slide principle, and yet stamped with the words **R.C.&C.'S PATENT** (fig. 7), and also **MORTONS PATENT**.

A rather ingenious method of adjusting the slides of these candlesticks, which seems to be an improvement on Eckhardt's, is here illustrated. This is worked by merely unscrewing the telescopic slide, and then expanding with the fingers the inside pillar of the candlestick until it binds more securely to the outside tube or pillar. This is easily accomplished, as the tube is slit up at the end into two divisions (see figs. 6 and 9).

As will be readily understood, therefore, there is considerable confusion attached to these patent slide candlesticks; and to make matters still more complicated, candlesticks have been found similar in style to the telescopic

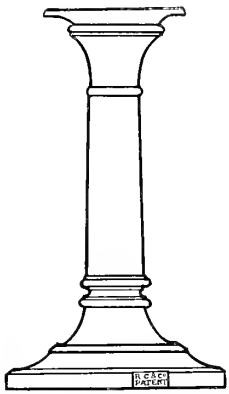

1—Ordinary Candlestick without Slide, but marked R. C. & Co. patent.
Date 1800. Author.

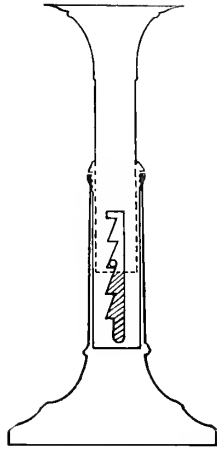

2—Roberts' Patent Slide Candlestick.
Date 1797. Author.

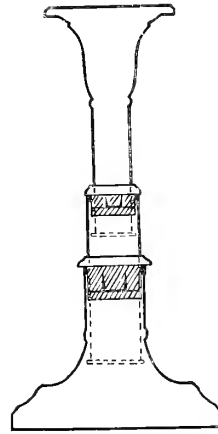

3—Eckhardt's Patent Candlestick, showing the double slide, stick extended.
Date 1796. Author.

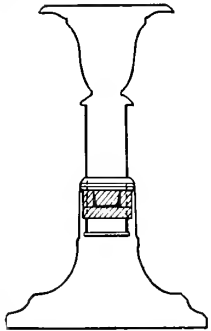

4—Eckhardt's Patent Single Slide Candlestick.
Date 1796. Author.

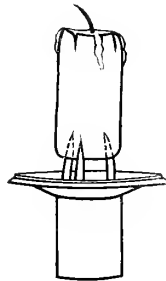

5—Ingenions contrivance, not patented, to fit in the nozzle to hold the Candle end. Author.

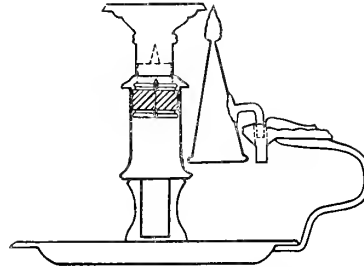

6—Slide Stick, in the form of Chamber Candlestick.
Date 1809. Author.

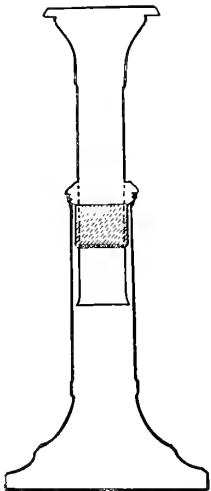

7—Ordinary Slide Candlestick, marked R. C. & Co. patent.
Date 1798. Author.

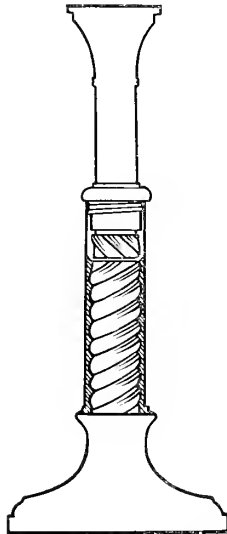

8—Candlestick Slide, on the Archimedian principle (not marked patent).
Date 1805. Author.

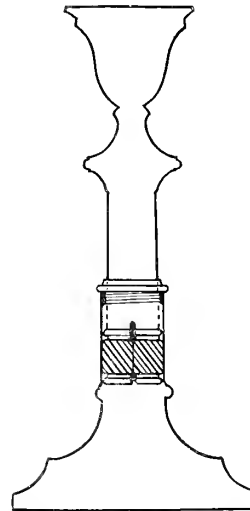

9—Candlestick, the slide of which can be adjusted by the slit in the inner tube as shown.
Date 1809. Author.

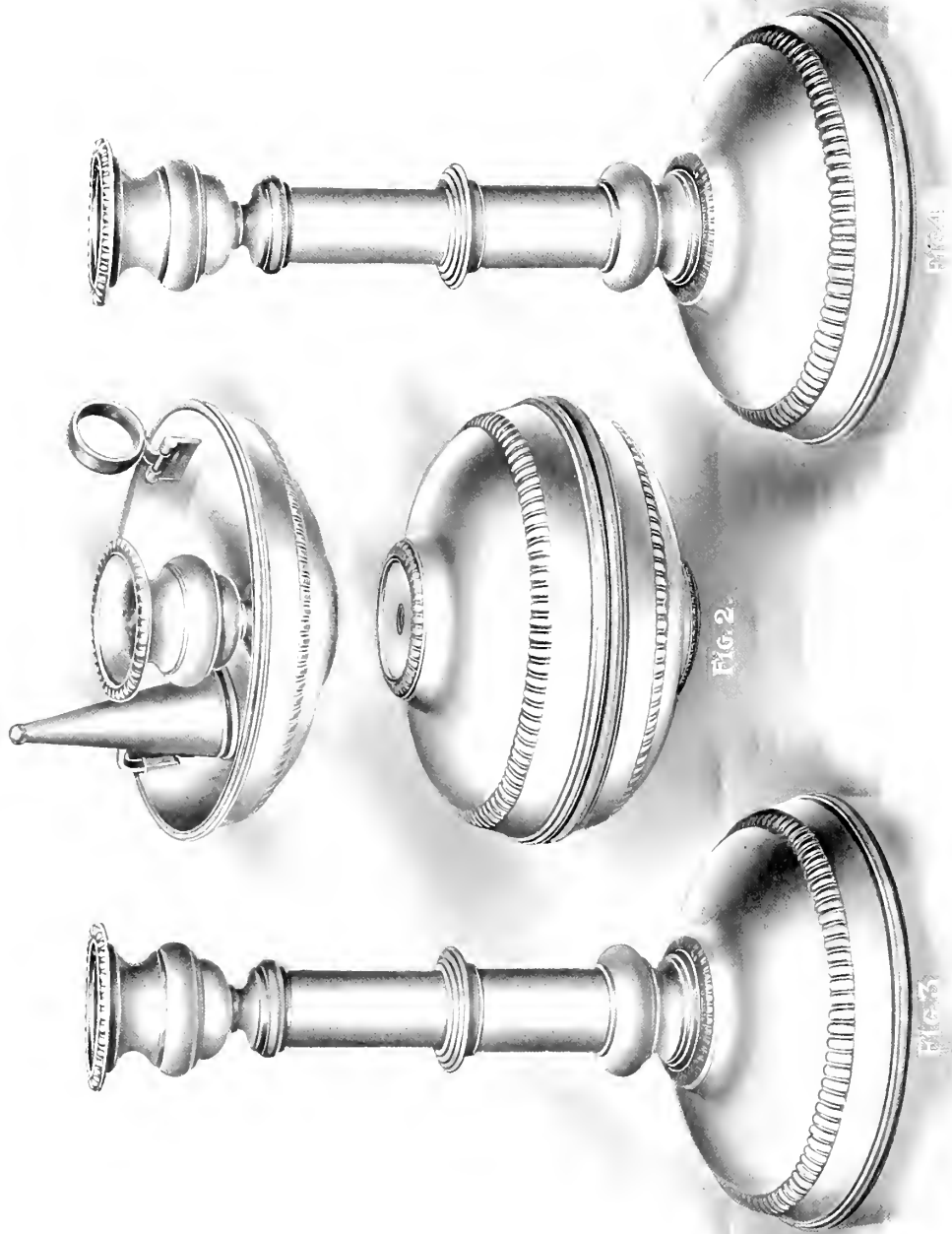

Pair 9¼ in. Telescopic Candlesticks, arranged to fit compactly inside the two bases, or to be used as a Chamber Candlestick (probably one of Roberts & Cadman's conceptions).
Date 1805.
Mr. W. P. Belk, Sheffield.

stamped with the word "patent" on them, although not manufactured on the sliding principle. This may be simply a mistake on the part of the workman charged with the duty of attending to marking.

A very curious combination of candlesticks is sufficiently interesting to illustrate here in detail. The date of manufacture is fixed at about 1805. It consists of, fig. 2, a chamber candlestick, extinguisher and nozzle, with two telescopic pillars complete, all packed up inside the two bases, ready to place in a valise preparatory to making a journey by coach. Fig. 1, the inverted base of stick, forming a foot for the complete chamber candlestick as shown; and figs. 3 and 4, all the parts in use together, and built up, forming a pair of ordinary table candlesticks of telescopic construction, $9\frac{1}{4}$ inches high. It is almost impossible to imagine how all these various parts could be packed away in so small a compass as was provided by the two inverted bases shown in Fig. 2, $3\frac{1}{2}$ inches high \times $5\frac{1}{4}$ inches diameter.

Complications in tracing the manufacturer of a particular pattern of candlestick are increased by the local makers having made it a practice to trade with each other. Silver candlesticks struck out of the same dies have been found which bear the imprint of the punches of various Sheffield manufacturers.

By the year 1773 the firm of Winter, Parsons & Hall had become by far the largest makers in the candlestick trade; where they acquired their excellence in design remains a mystery—possibly by confining their attention principally to the production of one class of goods.

In all probability Winter and Parsons manufactured principally for the trade in general. It would not, one would suppose, have paid them to send representatives out into the country and abroad with the object of securing orders for these articles alone. Hence we find a large proportion of their candlesticks bearing both London silversmiths' names and the London silver assay mark. It seems unlikely that in competition with both the Sheffield and London manufacturers and merchants, they would have obtained the great support accorded to them by the wholesale trade.

It must be remembered that the designations Ionic, Corinthian, Egyptian, and so forth, as employed by silversmiths, are not strictly accurate in an architectural sense. While largely availing themselves of classical examples, the designers deviated freely from the severe purity of the source of their inspiration and introduced many alien details. Thus their loose nomenclature indicates the basal motive of their compositions, but does not imply exact imitation of pure types.

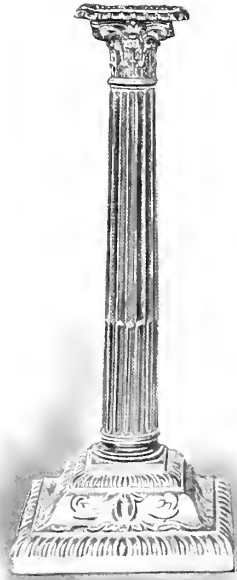

12 in. Corinthian Candlestick,
by J. Hoyland & Co.
Date 1763 Wood, Nottingham.



14 in. Corinthian Column Candlestick, with
composite capital, Adam base, and
step foot, by J. Winter & Co.
Date 1768. Mappin & Webb, London.



12 in. Plain Column and Foot, Bead
Mount Candlestick, by J. Winter & Co.
Date 1773. Author.

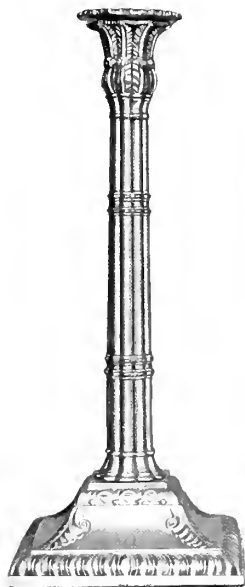

12 in. Reeded Candlestick,
by T. Law.
Date 1765. Lake & Son, Exeter.

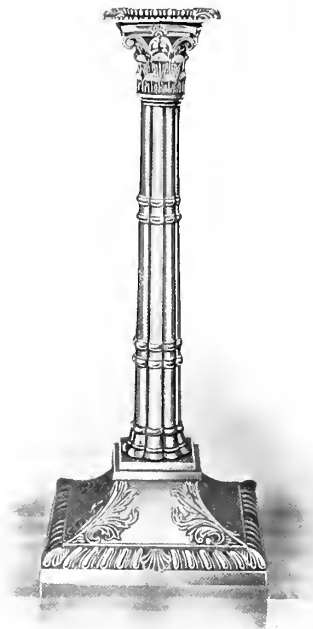

12 in. Candlestick, showing reeded pillar in use
but with a different foot and capital, by T. Law.
Date 1770. Author.

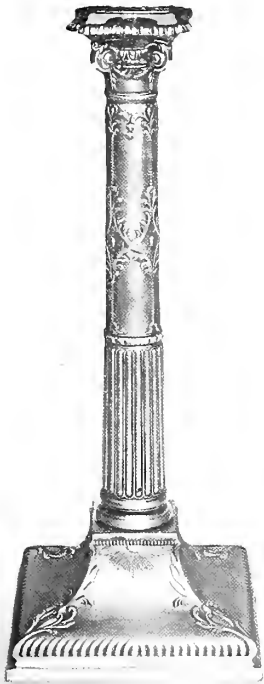

13 in. Composite Candlestick, by
Tudor & Leader.
Date 1775. Wood, Nottingham.

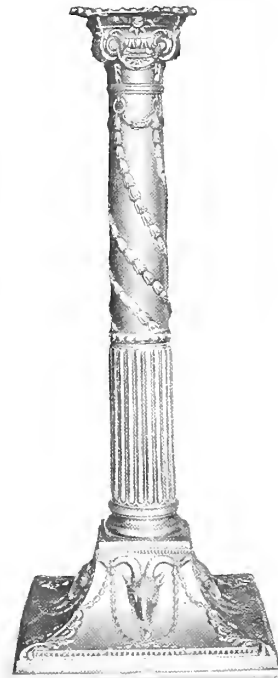

13 in. Composite Candlestick, by
Tudor & Leader.
Date 1776. Author.



13 in. Composite Candlestick, showing
how a third pattern has been made from
the same dies by interchanging the parts
of the two illustrated above, by
Tudor & Leader.
Date 1778. Author.



11 in. Flaxman Candlestick, by
J. Winter & Co.
Date 1779. Author.



11½ in. Flaxman Candlestick, by
M. Fenton & Co.
Date 1779. Author.



11 in. Adam Candlestick, by J. Winter & Co.
Date 1776. Mr. F. C. Wheeler, London



12 in. Adam Candlestick, by J. Winter & Co.
Date 1778. Vander & Hedges, London.



11 in. Adam Candlestick, with same
pillar and capital as illustrated
above, but different foot.
Date 1780. Author



12 in. Adam Candlestick, by M. Fenton & Co.
Date 1778. Lake & Son, Exeter.



12 in. Adam Candlestick, by M. Fenton & Co.
Date 1778. Author.



12 in. Pompeian Candlestick, by
M. Fenton & Co.
Date 1776. Author.

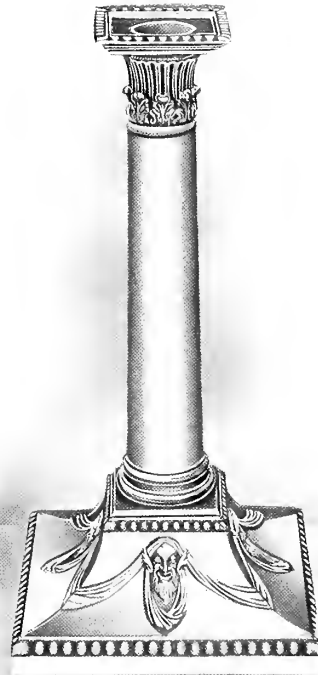

12 in. Plain column mask foot Candlestick,
by J. Winter & Co.
Date 1778. Author.



12 in. Plain column, festoon foot Candlestick,
by T. Law & Co.
Date 1778. Author.

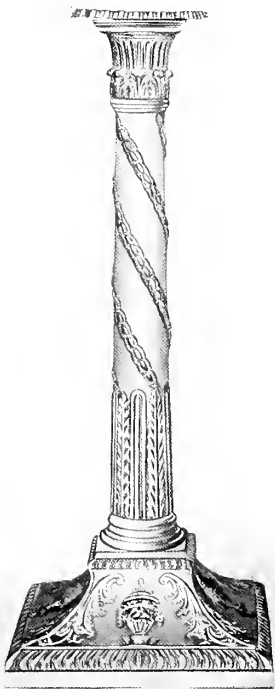

13 in. Candlestick (made up of various
other Candlestick parts), by
J. Winter & Co.
Date 1779. Cambray, Oxford.



13 in. Oak Wreath Pillar Candlestick,
by J. Winter & Co.
Date 1773. West & Son, Dublin.

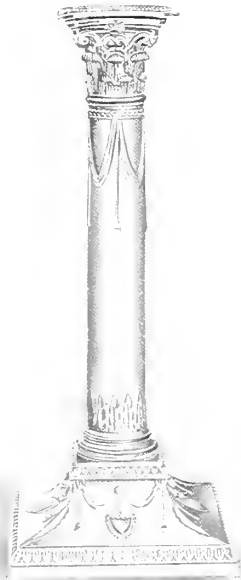

11½ in. Adam Candlestick.
Date 1779. Author.



7 in. Fluted Candlestick, with draped
pillar, by Tudor & Leader.
Date 1780. Author.



3½ in. Adam Candlestick,
by J. Winter & Co.
Date 1778 Author.

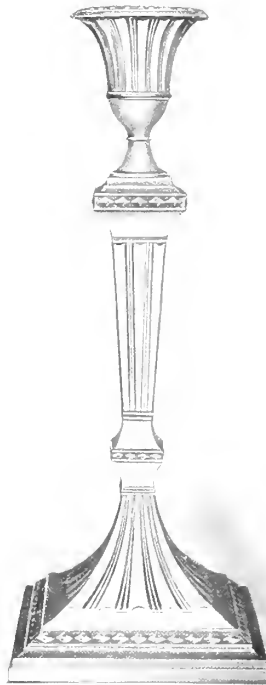

12 in. Lozenge Ornament Candlestick,
by J. Parsons & Co.
Date 1784. Author.

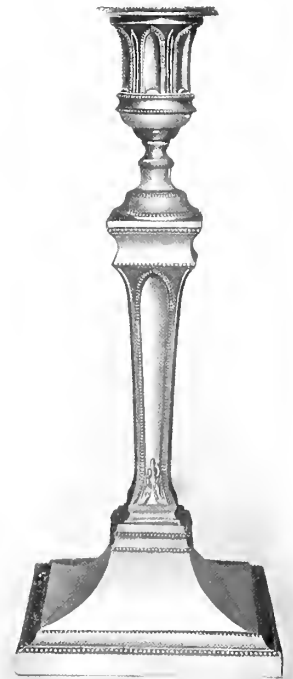

12 in. Shaped Bead Pattern Candlestick,
by Tudor & Leader.
Date 1786. Author.



11 in. Candlestick, with chevron decorative ornament, by M. Fenton & Co.
Date 1786. Author.

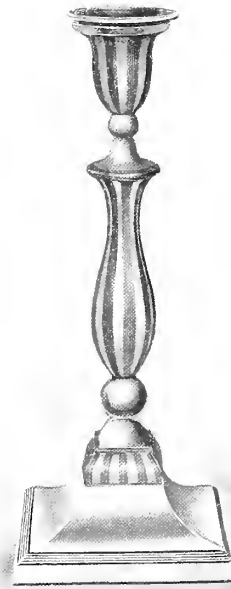

11 in. Thread Ornament Candlestick, by J. Parsons & Co.
Date 1788. Mr. G. R. Travis, Sheffield.

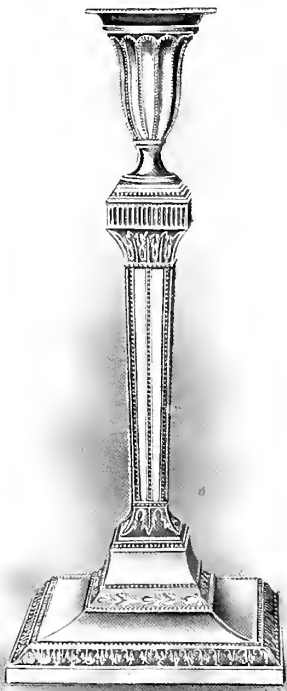

12 in. Acanthus and Bead Candlestick, by J. Parsons & Co.
Date 1785. Author.

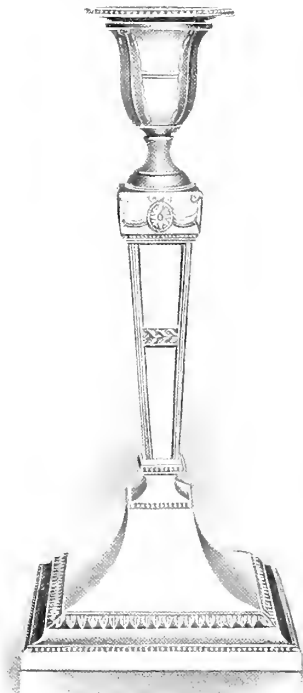

11 in. Adam Candlestick, by J. Parsons & Co.
Date 1782. Lake & Son, Exeter.



11 in. Round Base Candlestick, with bead and
chevron decorative ornament by
M. Fenton & Co. Author.
Date 1789.

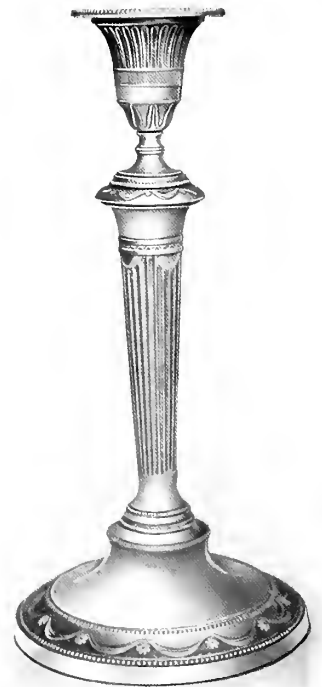

11 in. Festoon Base Fluted Pillar Candlestick,
by J. Parsons & Co. Author.
Date 1784.



10½ in. Oval Fluted Candlestick, marked
"R & W." Author.
Date 1793.

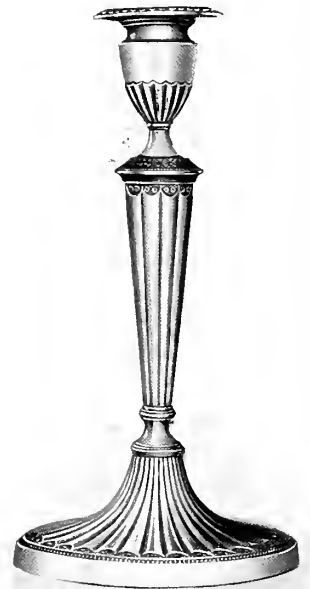

11 in. Oval Egyptian Candlestick, by
Watson & Bradbury.
Date 1796. D. & M. Davis, Birmingham.



10½ in. Medallion Pattern Candlestick,
by J. Parsons & Co.
Date 1789. Paget, Cheltenham.



11½ in. Oval Shaped and Fluted Candlestick,
by T. Law & Co.
Date 1792. Author.



11½ in. Oval Plain Canoe Candlestick, by
Watson & Bradbury.
Date 1795. Author.



11½ in. Oval Fluted Canoe Candlestick, by
T. Law & Co.
Date 1793. Author.

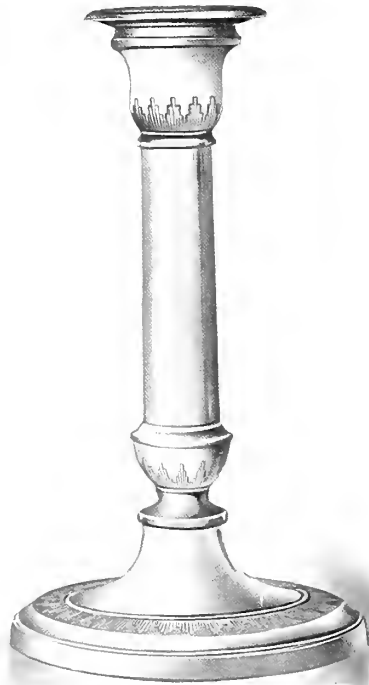

10½ in. Oval Shaped Candlestick, by
Watson & Braithbury.
Date 1798. Author.



10½ in. Candlestick (a 12 in. pattern minus
capital), by Morton & Co.
Date 1785. Author.



9½ in. Oblong Shell Pattern with flutes Candlestick,
by N. Smith & Co.
Date 1805. Author.



10½ in. Oval Octagonal Candlestick, by
J. Parsons & Co.
Date 1788. Author.



10½ in. Caryatid Candlestick, designed by Sir F. Chantrey, by Gainsford & Nicholson.
Date 1812. Mr. A. Nicholson, Sheffield.



11½ in. Caryatid Candlestick, a very rare specimen of early die work.
Date 1750—1760. Sir T. Freake, Monmouth.

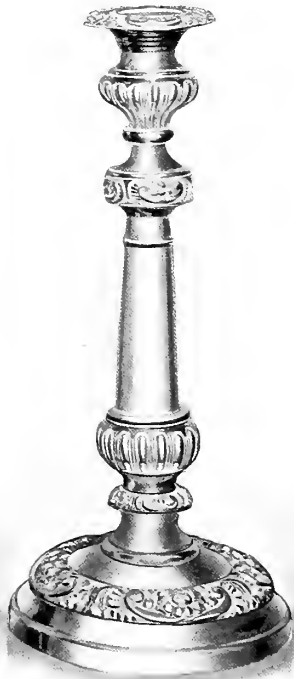

12 in. Candlestick, with florid mounts, by Watson & Bradbury.
Date 1818. Author.



9 in. Fluted Telescopic Candlestick, by Roberts, Cadman & Co.
Date 1810. Author.



5½ in. Candlestick, purchased in Holland, most likely made for the Dutch Market, by M. Fenton & Co.
Date 1778-1788. Author.



10½ in. Candlestick, with Floral Mounts,
by Watson & Bradbury.
Date 1820. Author.



10½ in. Gadroon and Shell Candlestick, by
Matthew Boulton & Co.
Date 1816. Spink & Son, London.

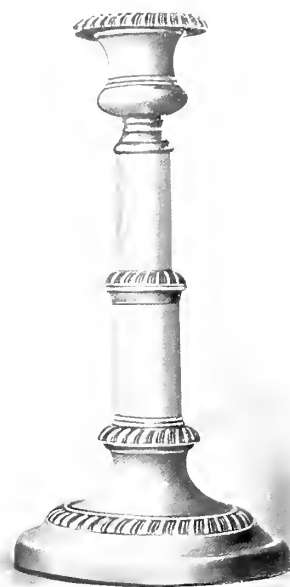

10½ in. Plain Gadroon Telescopic Candlestick,
by Roberts, Cadman & Co.
Date 1815. Author.



9 in. Florid Shaped Candlestick, by
H. Wilkinson & Co.
Date 1834. Elkington & Co., London.



5 in. Candlestick, transitional period, silver
fused on German silver, with silver filled
mounts, by T. Bradbury & Sons.
Date 1838. Miss Bradbury, Sheffield.

CANDELABRA.

The original makers of candelabra took their inspiration from the form of a tree, the candlestick resembling the trunk and the candle branches spreading out like the branches of a tree. In the later days of the Sheffield Plate industry also, this seems to have been the idea mainly in view, the candelabra being so built up that they very greatly resembled tree trunks, foliage, leaves and blossoms.

Sheffield plated candelabra cannot be dated before the year 1770. Sketchley, in his list of goods manufactured in the year 1774, however, gives "branches" a place. Specimens of that period are very rarely to be met with to-day.

The interchangeable candelabra and *épergnes* were a great feature of the Sheffield plate trade. They were introduced some time after the year 1815, and took the place of the *épergne* and *cruet* combinations that had previously been so popular (see pages 290 and 291.) Perhaps we have to thank Chantrey for the introduction of innovations in their artistic construction. This is certainly the case as regards the design of the *caryatides* illustrated on pages 240 and 241.



Two-light Candelabrum, 18 in. high, with urn centre and hand-chased pillar, by Thomas Law.
(The branch not originally designed for this Candlestick.)

Date 1770.

Franklin & Hare, Taunton.



Two-light Candelabrum. 14 in. high, with urn
centre, and die struck pillar, by
J. Winter & Co.
Date 1778 Cambray, Oxford.

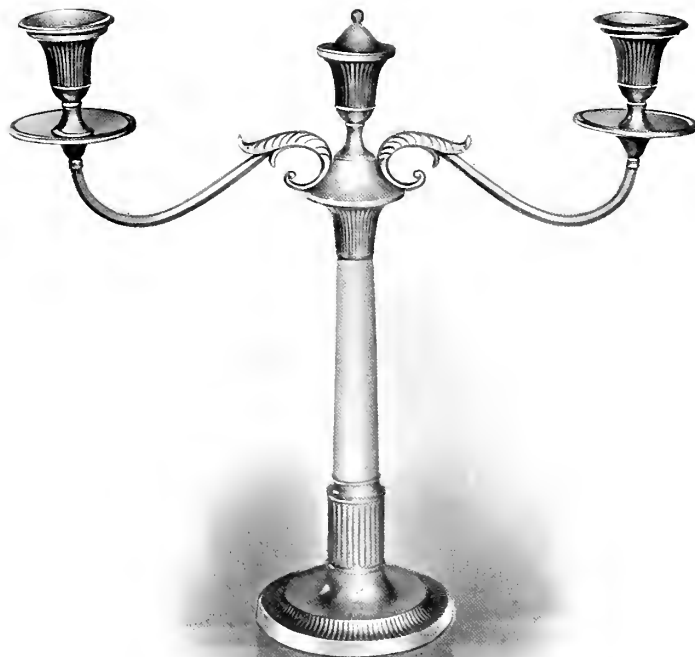

Three-light Candelabrum, 15 in. high,
by Morton & Co. (formerly property
of Marquis of Anglesea).
Date 1800. Mr. F. Hawley, London.



Two-light Candelabrum, 18 in. high,
with twisted wire arms, by
Roberts, Cadman & Co
Date 1803. D. & M. Davis,
Birmingham.



Three-light Candelabrum,
15 in. high, with twisted
wire arms and wire pillar,
by Roberts, Cadman & Co.
Date 1800. Davis,
Manchester.



Two-light urn centre Candelabrum, 15 in. high, with silver sticks and plated branches, by J. Parsons & Co.
Date 1792. Mr. G. R. Travis, Sheffield.



Three-light oblong base Candelabrum, 18 in. high, by Watson & Bradbury.
Date 1802. Lambert, London.

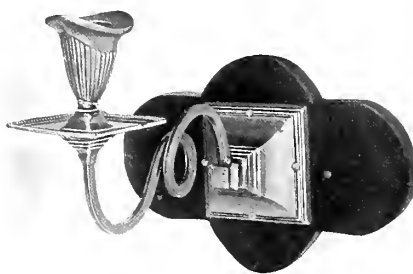

Single arm wall bracket Sconce, by J. Parsons & Co.
Date 1795. Author.



Two-light round Pillar Candelabrum, 15 in. high, marked "silver borders,"
by Matthew Boulton & Co.
Date 1790. The Castle Hotel, Taunton.

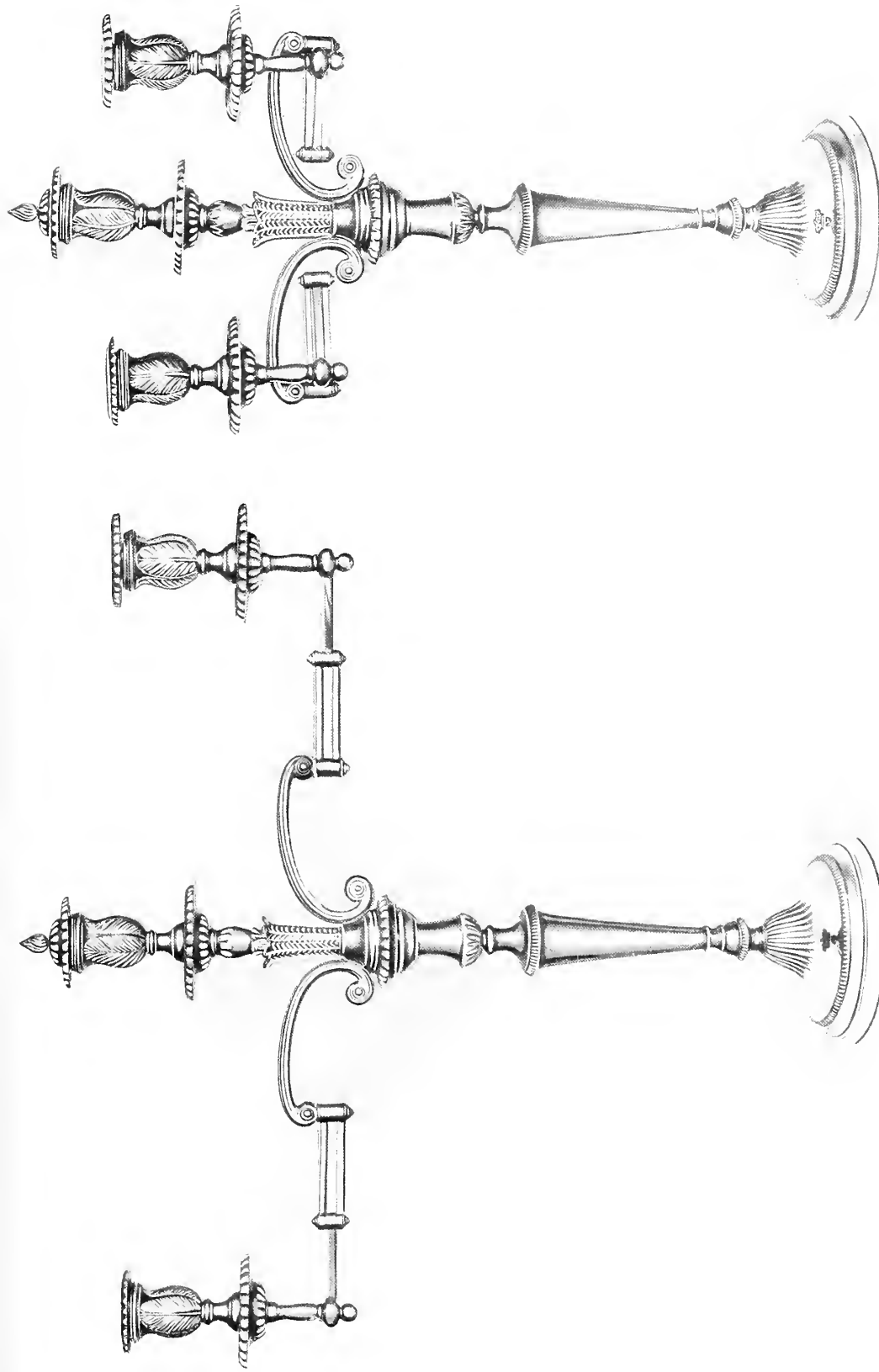

Three-light folding bracket Candelabrum,
with arms closed in.

Three-light folding bracket Candelabrum, 23 in. high, with arms extended, by J. Green and Co.
Galton, Christchurch.

Three-light folding bracket Candelabrum, 23 in. high, with arms extended, by J. Green and Co.
Date 1805.

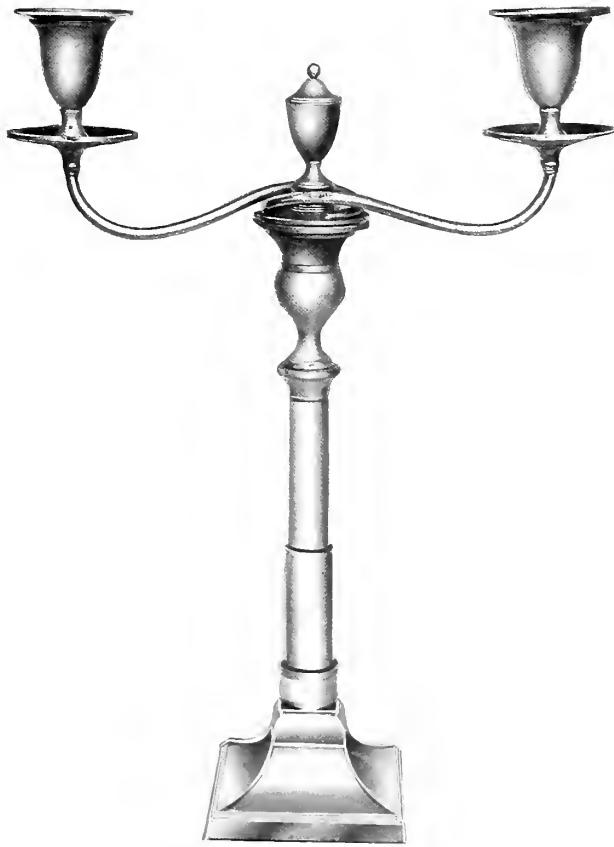

Eckhardt's patent Candelabrum, elongated, 17½ in. high,
with square base, by Morton & Co. Lake, Exeter.
Date 1797.



Eckhardt's patent Candelabrum, elongated, 21½ in. high,
with round base, by R. Morton & Co. Author.
Date 1800.



Eckhardt's patent Candelabrum, closed, 13 in. high.



Eckhardt's patent Candelabrum, closed, 16 in. high.



Interchangeable Three-light Candelabrum, 32 in. high, by T. & J. Creswick.
Date 1816. Curtis & Horspool, Leicester.



Interchangeable Four-light Candelabrum and Epergne, with caryatides supports, height 22 in., spread of arms 16½ in. (designed by Sir Francis Chantry), by Gainsford & Nicholson.

Date 1812.

Author.



Interchangeable Epergne and Four-light Candelabrum, with caryatides supports, height 16 in., spread of arms 18 in.,
(designed by Sir F. Chantry), by Gainsford & Nicholson.

Date 1812.

Author.



Interchangeable Five-light Candelabrum, 27 in. high, by T. & J. Creswick.
Date 1818 E. & E. Emanuel, Portsea.

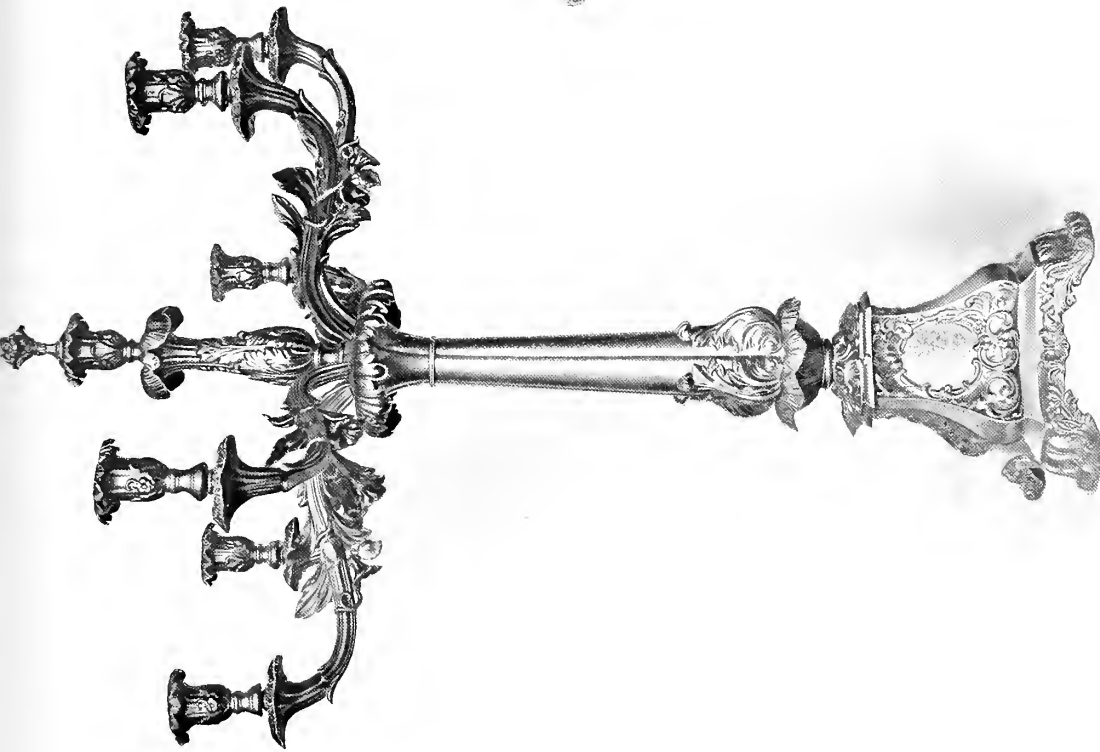

Interchangeable Seven-light Candelabrum and Five-glass Epergne,
height 35 in., spread of arms 24 in., by Roberts, Smith & Co.
Date 1830.
Mr. W. T. Sears, Northampton.



Interchangeable Five-glass Epergne and Seven-light Candelabrum,
height 21 in., spread of arms 27 in.
Date 1830.
Mr. W. T. Sears, Northampton.

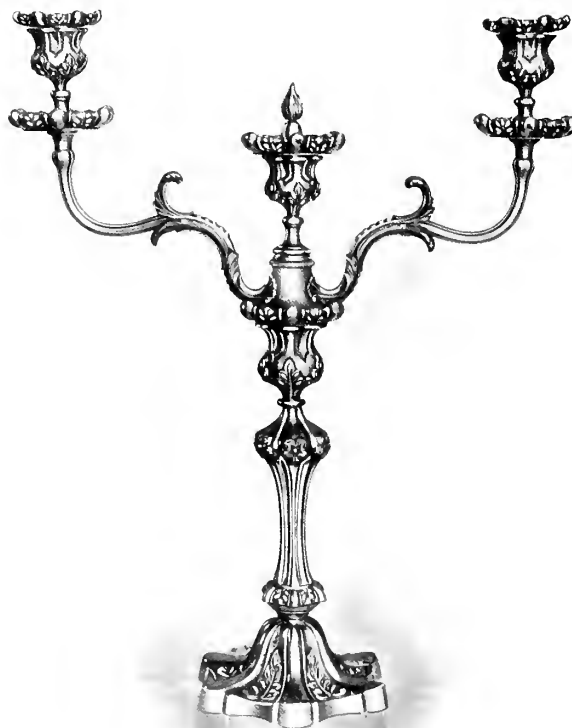

Three-light Candelabrum, 19 in. high, by J. Dixon & Son,
Date 1838. Mr. A. Nicholson, Sheffield.

CANDLE SNUFFERS.

Mr. H. C. Casley, of Ipswich, says, concerning the illustrated eccentric Old Sheffield-made silver-mounted and close-plated steel snuffers here illustrated: "In the days of our grandfathers, and even in the early days of our own parents, the only form of candle used was the wax (which was far too costly for anything but dinner parties), and the tallow dip, which was simply tallow upon a heavy twisted cotton wick, and in its commoner and earliest form the wick was sometimes made of rush. There were gradations

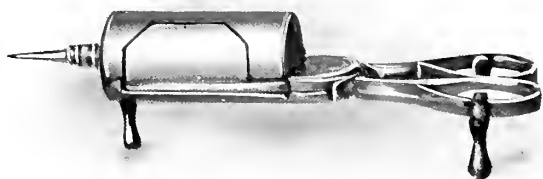

Close-plated steel Snuffers, manufactured under John
Wilkes' patent, by Willmore, Birmingham.
Date 1807. D. & M. Davis, Birmingham.

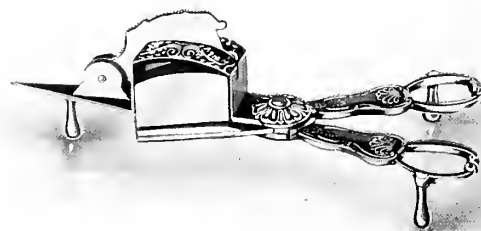

Eccentric close-plated steel Snuffers, showing the
patent action as described by Pinchbeck in 1776,
(see next page).
Date 1820. Mr. H. C. Casley.

of quality in these candles—those made for the parlour being moulded, and of composite tallow, with a plaited wick somewhat better than the one used for the kitchen departments ; but the fact remains that the wick used rapidly to char, and if not snuffed with tolerable frequency smoked villainously. Unless the charred portion of the wick was carefully snuffed off and deposited, it fell on the cloth or flew about the room, and left nasty, black, greasy streaks, which no doubt was the origin of this special form of snuffer, which provided a sure depository for the charred end when cut off.”

His remarks are well worthy of notice, not only on account of the enormous number and variety of styles in these steel snuffers, but also because the manufacture of them is entirely a lost art as far as can be ascertained from enquiries of the old scissors-smiths in the city of Sheffield, though there is a possibility that the trade may still linger on in London or Birmingham.

The appended list of patents in connection chiefly with snuffers and candlesticks gives some idea how for nearly a century the brains of a large section of the community appear to have been concentrated on this subject of light, how to regulate it, and how most successfully to extinguish it, without fear of any damage to the household generally. About the year 1840 were first introduced candles whose wicks burnt down without the necessity for snuffers.

- 1749. Cartwright's specification is the earliest to be found for spring snuffers.
- 1768. Chrstr. Pinchbeck's patent for keeping the candle vertical when carried, adjusted by a weight, and also a screwed-in spring to the nozzle to avoid the use of packing (this is still being used), is the first to be traced bearing on this subject.
- 1769. Joachim Smith's patent for raising the candle automatically as it burns, by means of a spring.
- 1776. Christopher Pinchbeck brought out the first patent spring snuffer for securely locking up the discarded wick, and putting out the spark.
- 1777. John Trusler on similar lines, but working laterally.
- 1779. Edmund Greaves' patent for bringing up the candle by turning a screw.
- 1800. Raybould's patent. An adjustable patent for securing and holding candles firm.
- 1801. John Wilkes' patent for making a cylindrical spring snuffer for candles, which cuts off, confines, and extinguishes the snuff at one motion.
- 1805. William Kent patents an invention for the chamber candlestick by which, when burnt down, the remains of the stick fall into water, a guard being also fixed, made of horn or glass to conduct sparks into the water.
- 1809. John Duff brings out a pair of patent snuffers, the principle of which, he says, was communicated to him by a foreigner.
- 1809. George Alexander Thompson patents a pair of spring snuffers whereby the wick of a candle is cut and kept in perfect trim and of a proper length.
- 1810. Samuel Hobday, of Birmingham, brings out a patent for snuffers to act without springs by the application of a lever alone.



Ordinary close-plated spring Snuffers, with heavy silver mounts.



Ordinary close-plated spring Snuffers, silver mounts.

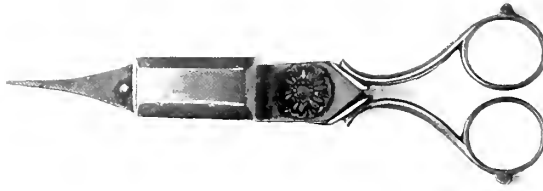

Ordinary plain close-plated spring Snuffers.



Eccentric close-plated Snuffers, silver mounts. Harwood, Birmingham. "W. R. 1830."



Eccentric steel Snuffers (Pritchcock's patent), silver bows, hall marked in 1797.

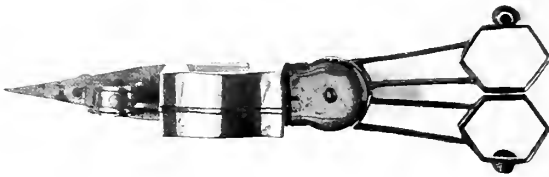

All steel patent eccentric Snuffers. "W. R. 1830."

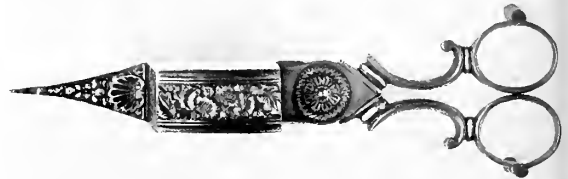
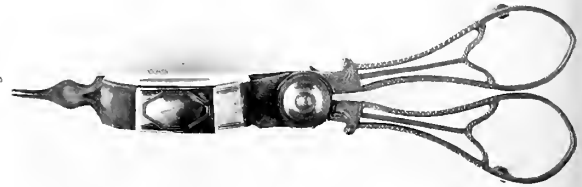
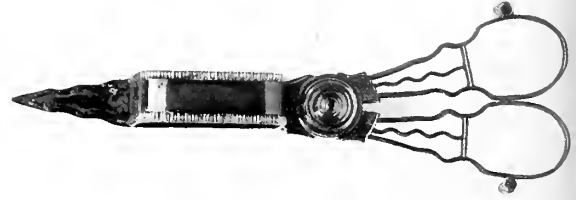
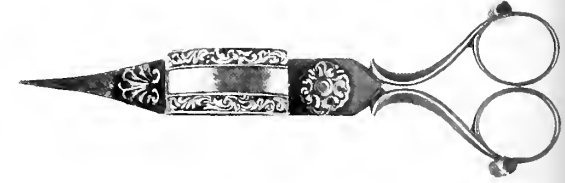

1811. Abraham Willis brings out a patent for many articles in daily use, including snuffers.
1812. Leger Didot brings out some very complicated additions to candlestick patents.
1813. Charles Goodwin patents an improved socket for fixing in the candle without packing, also a self-extinguisher.
1817. Robert Salmon patents an improved apparatus for holding the candle in its socket.
1818. Samuel Hobday patents a snuffer again, this time without either springs or lever.
1821. Thomas Motley patents certain improvements in the construction of candlesticks or lamps, and candles to be burnt therein.
1821. Thomas Lees the younger patents improvements in snuffers, " which consists of perfectly extinguishing and preventing the re-ignition of the snuff by pressure and the exclusion of atmospheric air independently of the opening of the blades of the snuffer."
1821. James Simpson, a surgical instrument maker of London, patents a steel snuffer " with compound levers on the handles to retain the snuff in the receptacle chamber when re-opening the snuffers."
1832. William Palmer patents an apparatus for making candles and for holding same.
1835. Thomas Walker patents a self-acting extinguisher for candlesticks with springs, by means of a pin brought in contact with a catch or stop.
1837. Henry Needham Scrope Shrapnel patents certain improvements in snuffers " to retain the snuff by means of a series of spikes or projections in the receptacle."
1839. James Barlow, of Birmingham, patents certain improvements in the construction of candlesticks principally for holding the candlestick.
1839. Charles Greenway, of Douglas, Isle-of-Man, patents an improvement in snuffers, to retain the snuff.
1841. John Lee Stevens and John King patent improvements in adjusting and holding of the candlestick.
1842. Septimus Cocking, of Birmingham, patents certain improvements in the production of light by the burning of oil, tallow and wax, and in the apparatus for regulating and extinguishing the same.
1842. Francis Prime Walker, Junior, patents certain improvements in the manufacture of candles and candlesticks, consisting of an improved candlestick for holding three separate candles so near together that when ignited they unite in one flame, and an automatic holder to accommodate candles of different diameters, also improved snuffers.
1842. Thomas Clive, of Birmingham, patents certain improvements in the construction of candlesticks consisting of an improvement in the " push-up " of candlesticks, and also an elastic holder for holding the candle securely.
1842. William Young patents improvements in lamps and candlesticks.
1842. Mark Freeman patents improvements in candlesticks, apparatus and instruments employed in the use of candles and rushlights.
1842. Frederick Oldfield Ward and Mark Freeman, patents consisting of refrigerating caps.
1844. John Butt patents " certain improvements in candlesticks " (no specification enrolled).

It will be quite a study for collectors to pick out from the above list the particular inventor to whose brains they are indebted for the snuffers they possess. Nearly all snuffers bear some indication by marks, letters patent, or otherwise, of their origin.

CHAMBER CANDLESTICKS.

As their name implies, these were, and still are, entirely for bedroom purposes. Notwithstanding the advent of gas and electric light, the chamber stick is still in constant use, and likely to remain so as long as people continue to devote a last half hour to reading in bed by candle light, this being still considered the best way of composing one's mind for the night's rest.



Round bead mount Chamber Candlestick, with snuffers, by Tudor & Leader.
Date 1787. Leighton, Lancaster.

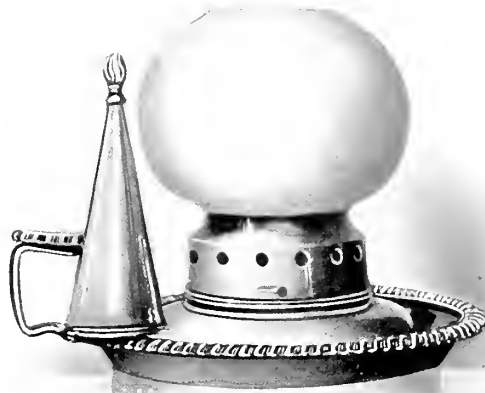

Round gadroon mount Chamber Candlestick, with
globe, by Watson & Bradbury.
Date 1803. Robinson & Co., Shrewsbury.

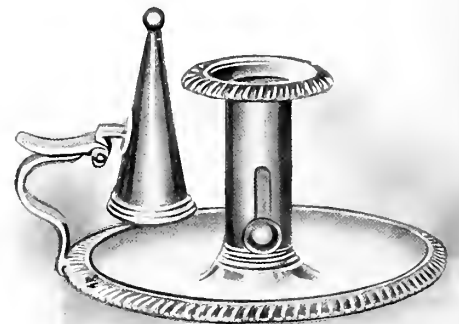

Round gadroon mount Chamber Candlestick,
with thumb piece for pushing up candle, by
Roberts, Cadman & Co.
Date 1815. R. Smith & Sons, Scarbro'.

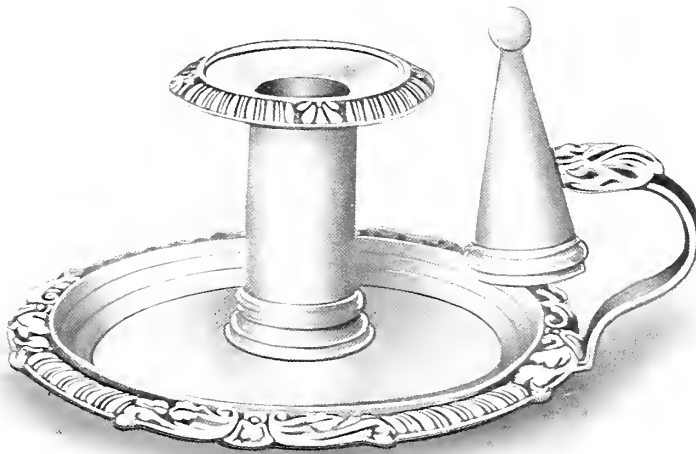

Round Chamber Candlestick, by M. Boulton & Co., Birmingham.
Date 1817. Author



Oblong gadroon mount Chamber Candlestick,
with snuffers, by Tucker, Fenton & Co.
Date 1808. Author.



Oblong dished plate Chamber Candlestick,
with snuffers, by J. Watson.
Date 1805. Author.

TAPER CANDLESTICKS.

Another branch of the candlestick family was the small taper stand used for melting the wax when sealing letters in the olden days. These are all very attractive little ornaments now very much in demand by collectors of Old Sheffield Plate as cabinet specimens and drawing room ornaments. The taper stick was usually secured to an inkstand, and very often formed

the top part of lid to the small box which held the wafers. Another form was one with a handle and bar running right across the middle of the article round which a long coil of wax could be wound and pulled through the top aperture or nozzle. This was called a "wax winder." A third variety was in a similar form, but enclosed in what was called a "bougie box," but this had not a winding handle, the coil of wax having to be pulled through by hand. At times, no doubt, all these three articles would be used as pipe or cigar lighters.

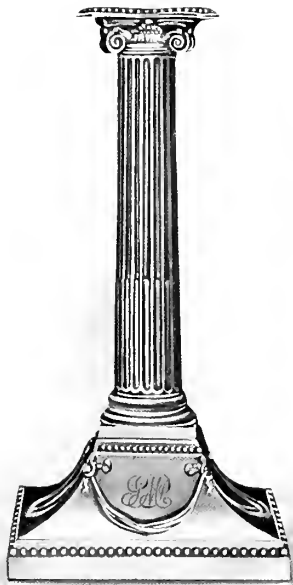

6½ in. Taper Candlestick, with Corinthian column, and draped foot, by J. Winter & Co.
Date 1781. Author.



6½ in. Taper Candlestick, with flat chasing on pillar, by T. Law.
Date 1772. Author.



5½ in. Shell pattern taper Candlestick, by Kitchen, Walker & Curr.
Date 1834. Author.

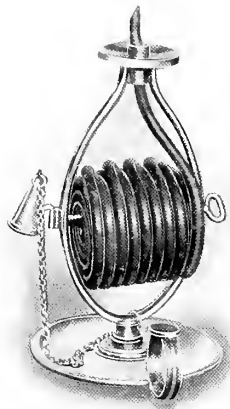

Wax Winder and Extinguisher, $4\frac{1}{2}$ in. high,
by Watson & Bradbury.
Date 1798. Franklin & Hare, Taunton.

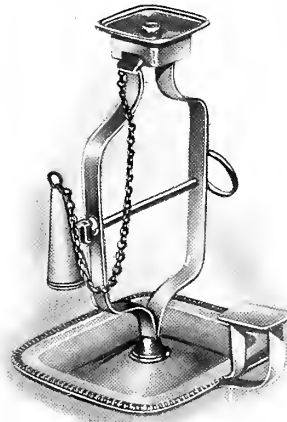

Wax Winder and Extinguisher, 5 in. high,
by N. Smith & Co.
Date 1803. Davis, Manchester.



Wax Taper or "Bougie Box," 3 in. high,
by D. Holy, Wilkinson & Co.
Date 1785. Author.



Wax Taper or "Bougie Box," $3\frac{1}{4}$ in. high, by
N. Smith & Co.
Date 1800. Withers, Upper Norwood.

CHEESE TOASTERS.

In Old Sheffield Plate cheese dishes were always in very great demand. The cheese was cut into thin slices and deposited on toast or bread in these dishes, which were then placed before the fire. Usually the insides of the dishes were divided up into sections. All dishes were fitted with hot water compartments and, as was the case with the vegetable dishes, the hot water could be poured into the jacket of the dish by unscrewing the handle or lifting up a small cap at the side. A chain was fixed from the knob of the dish to a small catch on the handle, which kept the dish lid raised so that the heat was reflected down on to the cheese, thereby considerably assisting the process of toasting. By the year 1830, cheese toasters had almost ceased to be manufactured.

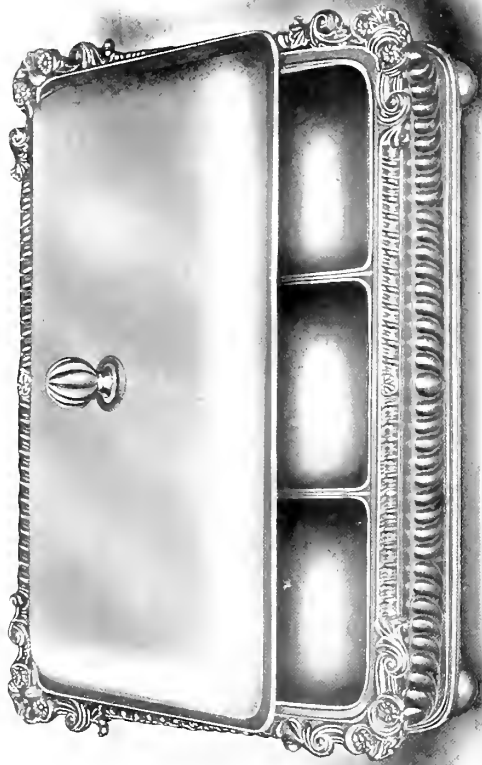

Oblong Cheese Toaster, 11 in. long x 8 in. broad, with fluted sides and loose hot water part, on ball feet, by Watson & Bradbury.
Heming & Co., London.
Date 1810

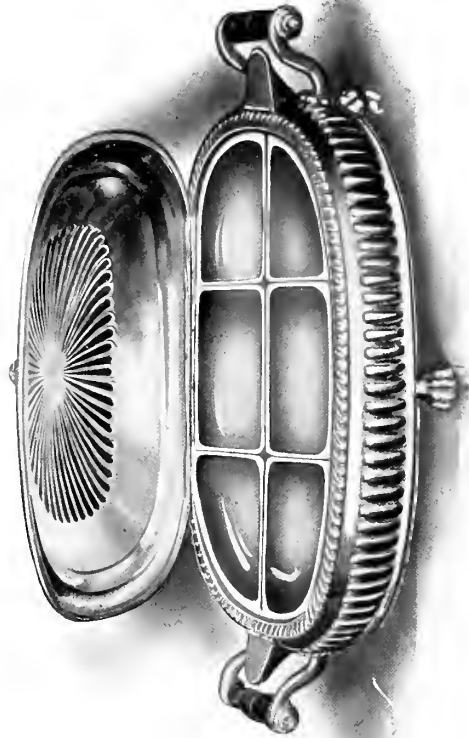

Oval Cheese Toaster, 10 in. long x 7 in. broad, with fluted sides and gadroon mount, end handles, and fixed hot water part, on claw feet, by Roberts, Cadman & Co.
Wood, Nottingham.
Date 1809.

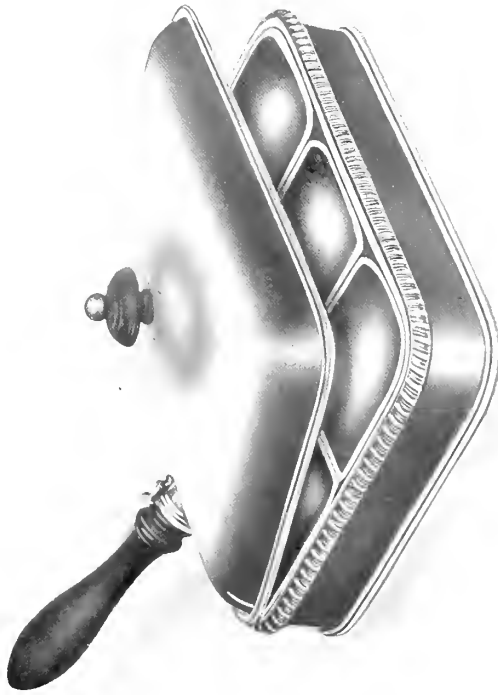

Oblong gadroon mount Cheese Toaster, 9½ in. long x 6½ in. broad, by M. Boulton & Co., Birmingham.
Date 1802.
Author.

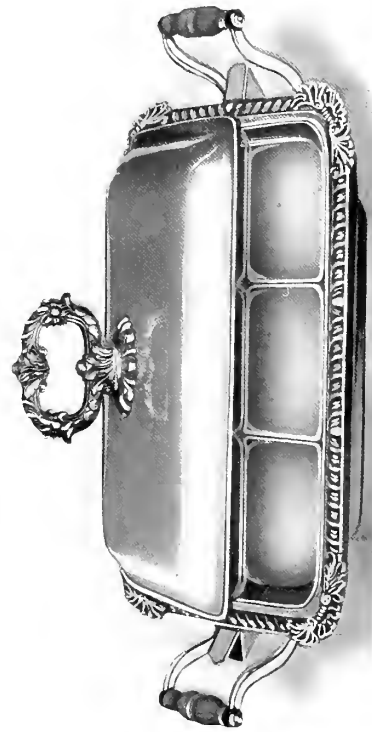

Oblong shell and gadroon mount Cheese Toaster, 10 in. long x 7½ in. broad, by Tucker, Fenton & Co.
Date 1807.
Author.

COASTERS.

The various descriptions given to what are usually termed "coasters" are somewhat confusing. Bottle trays or bottle stands are the names by which they are described in the oldest books of patterns, but such descriptions as "decanter" or "bottle" stands—or coasters for short—are to-day more usually given to them.

There were but few of these bottle trays made in the earlier days of the industry, not a sufficient number to enumerate them in the list of the year 1774. Towards the year 1800 their production had increased to enormous numbers, owing in a great measure to the introduction of silver edges, which was a great addition to their artistic appearance; and with the advent of ornate, heavily cut crystal decanters came the increase in the decorative



Cut-glass Decanter, with Wine Label and
Decanter Stand.
Date 1811. Author,



Old Cut-glass Spirit Bottle, 1 pint, with Old
Sheffield Label and Coaster.
Date 1815. Mr. F. Hawley, London.

designs of the coasters. 105 varied patterns of bottle trays are given in the extracts from old number book on page 196. The earliest forms of coasters, namely, the pierced ones, made before the year 1785, are very lacking in finish on their outer edges on account of the absence of these silver borders. In general they display a distinct copper appearance which detracts greatly from the beautiful variations of piercing to be found round their sides.

The origin of the "wine wagon" we must attribute to the inventive genius of Sir E. Thomason, of Birmingham, and in this connection the following extracts from his memoirs will be read with interest:—

"Many years since, Lord Rolle called upon me at my establishment, and said that he had dined with His Majesty George IV. the day before, and that His Majesty was pleased to remark that he regretted that his noble guests who sat on either side of him were constrained to rise from their seats to pass the wine, and observed to him (Lord Rolle), 'as you have said that you are going to Birmingham to-morrow, you had better call upon Thomason who may invent some plan to obviate this inconvenience.'

I suggested to Lord Rolle that decanter stands upon wheels was, in my opinion, the only method to be adopted; and as I held the beautiful dies containing the victories of the late war, forty in number, viz., from the landing in Portugal to the capture of Paris, and the settling of Napoleon at St. Helena, I recommended to place these medals around the flat perpendicular edges of the bottle stands, which would fill up four, thereby adapting them to two waggons, the whole made of silver and richly gilt, and each waggon to have beautifully ornamented wheels.* His lordship approved of my suggestions, and requested that no time should be lost in executing them, and when done to forward them to the Marquis of Conyngham. On their arrival, His Majesty expressed his entire approbation of the thought. Some time afterwards the King presented them to the Duke of Wellington." †

* Notwithstanding what is here recorded, wine waggons not very dissimilar to those illustrated are to be met with in both silver and Old Sheffield Plate apparently made late in the 18th century. Whether, however, such have been put together at a more recent date in the form of wine waggons from pairs of coasters, cannot be said with certainty.

† The versatility of Sir E. Thomason is shown by the advertised list of articles manufactured by his firm in the year 1808. "Edward Thomason's manufactory, Church Street, Birmingham, where by himself and partners are made all sorts of buttons, patent carriage steps, patent gun locks, patent corkscrews, patent hearth brushes, patent sword canes, telescope toasting forks, bronzed and other tokens. etc.; variety of plated articles on steel, jewelry of every description, gilt toys and military ornaments, silver snuff boxes, essence boxes, and medals."



Pierced Border Coaster, by J. Hoyland & Co.
Date 1770. Franklin & Hare, Taunton.



Pierced Tumbler Holder on feet, by J. Hoyland & Co.
Date 1774. Franklin & Hare, Taunton.



Pierced Coaster, by R. Morton & Co.
Date 1776. George, Bristol.



Shaped and Pierced Coaster, by N. Smith & Co.
Date 1780. Coopland, Sheffield.



Escalloped top pierced Coaster, by
Tudor & Leader.
Date 1782. Author.

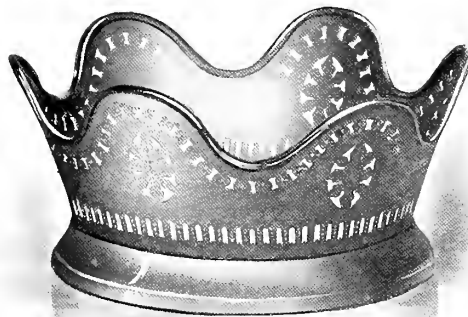

Escalloped top pierced Coaster, by D. Holy,
Wilkinson & Co.
Date 1785. Franklin & Hare, Taunton.



Wire Work Coaster, by R. Morton & Co.
Date 1791. Lambert, London.



Shell border fluted Coaster, by Roberts,
Clayton & Emory.
Date 1813. Author

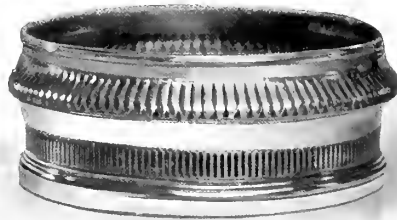

Shaped Fluted and Pierced Coaster,
by Watson & Bradbury.
Date 1798. D. & M. Davis, Birmingham.

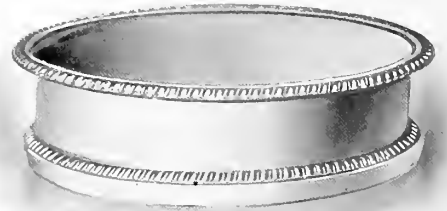

Double mounted Gadroon Coaster,
by J. Watson.
Date 1809 Leighton, Lancaster.



Fluted Coaster, by J. Roberts & Co.
Date 1811. Author.



Plain shaped Border Coaster, by
T. & J. Creswick.
Date 1816. Mr. N. Haggie, Whitburn.

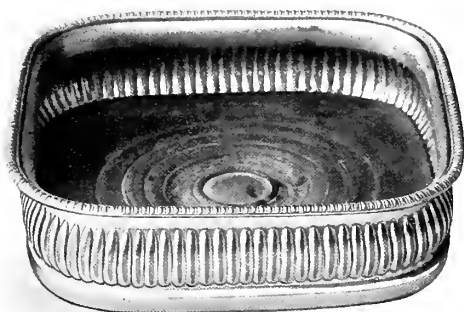

Fluted Coaster, of oblong shape, by
J. Roberts & Co. Author.
Date 1810.



Round Coaster, ornamented with scrolls and shells,
and fluted sides, by N. Smith & Co. Author.
Date 1815.



Shaped Coaster, with rosette mount, by
I. & I. Waterhouse & Co. Author.
Date 1830. Mr. H. B. Sandford, Sheffield.



Plain Coaster, with light ornamentation,
by T. Bradbury & Sons. Author.
Date 1835.



Wine Wagon, or double coasters on wheels, with shell and gadroon mounts, and shell and acanthus side
ornament, by Roberts, Clayton & Emory. Author.
Date 1820. Elkington & Co., London.

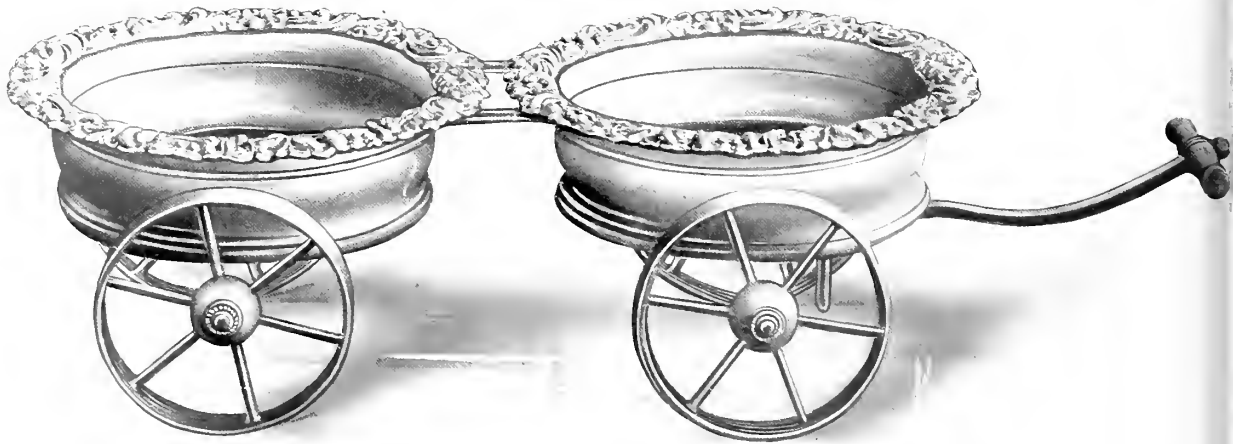

Wine Wagon, with scroll mounts and plain sides, by Battie, Howard & Hawksworth.
Date 1820 Lambert, London

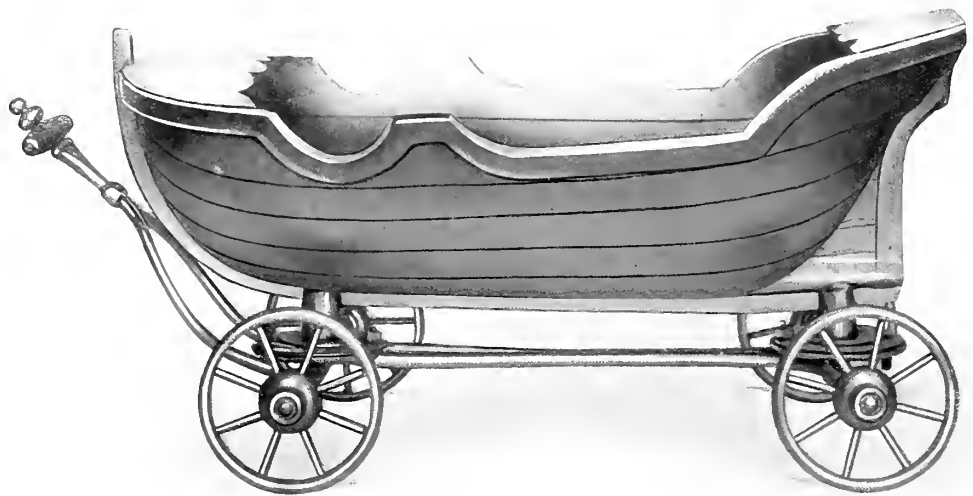

Wine Bottle Holder, in the form of a boat on wheels.
Date 1821. Elkington & Co., London.

COFFEE POTS.

Pots for coffee, made in Old Sheffield Plate, may be divided into four classes.

First we have the "coffee pot," taken in its conception from those in use in solid silver, when the plated trade as an industry first saw the light of day. These coffee pots are surprisingly numerous even now, and their thickness of copper, as well as of deposited silver, has stood them in good stead during the 150 odd years that have elapsed since they were first put on the market by the Old Sheffield platers (see first two illustrations, page 260). Next we come to the coffee "jugs," which appeared for the first time somewhere about the year 1787, after the introduction of silver mounts and other improved methods of manufacture (see page 262).

These articles are sometimes described as "biggins." Biggin or bagging is in the northern counties a dialectal word for refreshment taken between regular meals. Baggin-time is either 10 o'clock in the morning or 4 o'clock in the afternoon. Correctly described, a biggin is a can to hold a little more than a pint, made with

a deep lid or cover, which is loose and can be used as a saucer. A coffee biggin is a jug with lip and cover, inside which is a ledge on which a round wire can rest to hold the muslin bag for straining the coffee.



Combination Interchangeable Coffee Pot,
Stand and Lamp, and Teapot.
Date 1795. Author.



Combination Interchangeable Coffee Pot, Stand and Lamp, and Teapot, showing the Teapot separated from the top of
Coffee and Stand.

Date 1795.

Author.

Then came the coffee percolator (see illustration on top of page 262), and about the same time the smaller or side handled coffee pot, either with lip or spout, holding from three quarters of a pint to a pint and a half, with a stand and small lamp underneath (see page 263).

Chocolate pots were not articles extensively manufactured by the old platers, though Sketchley mentions them in his list in the year 1774. Only one pattern is described in the extracts of articles made between the years 1788 and 1815 given on page 197.



2-pint Coffee Pot, by Tudor & Leader.
Date 1760. Author.



2-pint chased Coffee Pot, by M. Fenton & Co.
Date 1765. Bruford & Son, Exeter.



2-pint Coffee Pot, by Kirkby,
Waterhouse & Co. Author.
Date 1805.



2-pint Chased Coffee Pot, by
T. J. & N. Creswick.
Date 1825. Mr. E. Hill, Woking.



2-pint Coffee Pot, with bead mount, by
T. Law & Co.
Date 1780. Author.



2½-pint Coffee Pot, with Soldered-in engraved shield,
by D. Holy, Wilkinson & Co.
Date 1795. Davis, Manchester.



2½-pint Coffee Pot, beehive pattern, by
Roberts, Cadman & Co.
Date 1805. George, Bristol.



2-pint Coffee Pot, with gadroon mounts,
made in Birmingham.
Date 1815. Author.



Fluted Coffee Percolater, by
T. & J. Creswick.
Date 1811. Dickinson, Bath.



2-pint Florid Mount Coffee Jug, by
T. & J. Creswick.
Date 1817. Franklin & Hare, Taunton.



1½-pint Coffee or Hot Milk Jug, by Eadon,
Kibble & Weaver.
Date 1798. Walford & Spokes, Oxford.



1½-pint Plain Coffee Biggin, by
A. Goodman & Co.
Date 1805. Robinson & Co., Shrewsbury.



1½-pint Plain Coffee or Hot Milk Jug, on stand,
with lamp, by Tucker, Fenton & Co.
Date 1803. Franklin & Hare, Taunton.



2-pint Plain Shaped Coffee Pot (part of a service), by J. Watson & Son.
Date 1828. Withers, Leicester.



¾-pint Coffee or Hot Milk Jug, by Ashforth,
Ellis & Co.
Date 1805. Robinson & Co., Shrewsbury.

COVERS FOR JOINTS AND VENISON DISHES, CHINA PLATES, ETC.

Dish covers are not very frequently found before the year 1800. 1810 is an approximate date that can be given for their introduction in long ranges or sets of sizes varying from 10" up to 24" in length, used at first chiefly by innkeepers. Only six varieties are described in the 1788-1815 pattern book. By the year 1820, in the revised edition then issued, this number has increased to 21. On the introduction of floreated designs, about the year 1815, they began to be very popular in private houses, whilst ten years later their proportions were truly magnificent, sets at that time ranging from 12" up to 26" in length. It is a pity that at the date of writing they are out of fashion, as perhaps no article lends itself better to an elaborate decoration than a large Old Sheffield plated dish cover.

The good old English joint, served hot at the mid-day meal, excepting at commercial and market dinners, is to-day almost a thing of the past, and as no one now desires to become an adept at carving, there is no longer any demand for the huge Old Sheffield 26" meat dish with the hot water container and 24" dish cover. These latter articles are still, however, occasionally to be found adorning the sideboards of hotels in country districts. Many covers were formerly made as shown in illustration on page 266 for use on china dishes, etc.



Dish Cover, from a service, two 15 in., one 18 in., with large filled silver handles and mounts, by T. J. & N. Creswick.
Date 1819—1829. The property of the 12th Lancers.



Series of Fluted Dish Covers with Gadroon Mounts, plated on both sides, 16, 18 and 20 ins.,
by Watson & Bradbury.

Date 1818.

Robinson & Co., Shrewsbury.

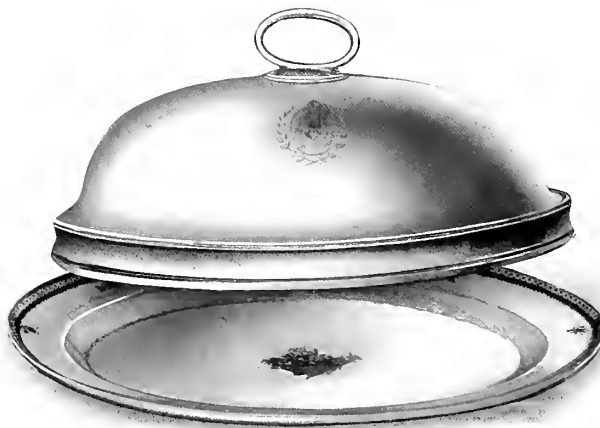

10 in. Oval Plain Cover, on an oriental china dish, by Tudor & Leader.
Date 1789. Author.



24 in. Venison Dish and Fluted Cover, with fixed hot water part, gadroon and shell border,
by D. & G. Holy & Co.
Date 1817. Vincent, Weymouth.

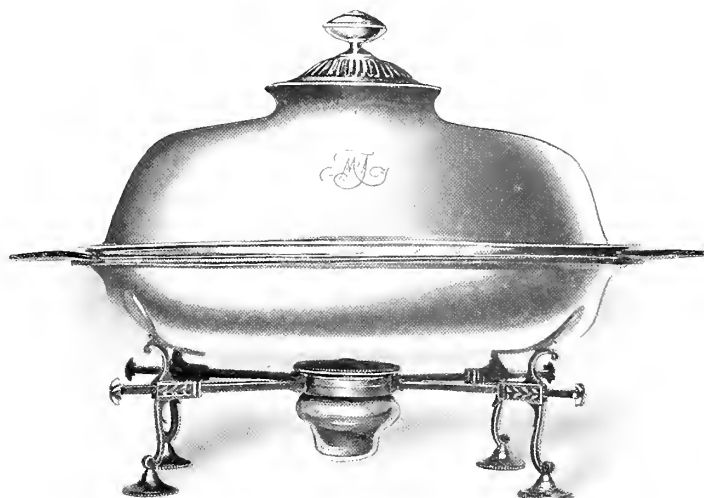

14 in. Oval Plain Breakfast Dish and Cover, showing the use of the "dish cross," by J. Younge & Co.

Date 1782.

Author.



24 in. Fluted Dish Cover, by D. & G. Holy & Co.
Date 1820. Cooplund, Sheffield.



11 in. Plain Dish Cover, by M. Boulton & Co., Birmingham.
Date 1812. Withers, Leicester.



20 in. Dish Cover, by M. Boulton & Co., Birmingham, on a 23 in. shaped gadroon Meat Plate.
Date 1818. E. & E. Emanuel, 3, The Hard, Portsea.

DINNER AND MEAT PLATES, ETC.

With the decline in use of large venison dishes and covers, the demand for large plated dishes of all kinds has also ceased.

To-day, plated meat dishes are numbered with many more old Sheffield wares as having outlived their utility for domestic purposes, though they are still to be met with in hotels and restaurants.

Possibly the enterprise shown of late years by the manufacturers of china in increasing their range of articles for domestic purposes, and also in cheapening their productions, may to some extent have caused the disappearance from our homes of many plated articles which were in daily use a century ago.

The old Sheffield dinner plate with dished top, shown in illustration at foot of next page, will be found a most serviceable article on which to place a china plate at meal times for keeping contents hot. One wonders why these plate warmers have to-day so entirely ceased to be used.

Complete services, consisting of meat and soup plates, in "sterling silver," are still however, frequently manufactured.

The huge knife, fork and spoon tray illustrated below, is an exceptional piece as regards size. It bears the crest of a well known English noble family, and has evidently been discarded. After the meal had been served, the cutlery, etc., was sorted and deposited in the three partitions shown. One would imagine, however, that the article itself would require almost as much cleaning as its contents.



Oblong Dish, with Gadroon and Shell mounts and three divisions for holding knives, spoons and forks, 22 in. long \times 15½ in. broad, by Blagden, Hodgson & Co.

Date 1816.

Lambert, London.

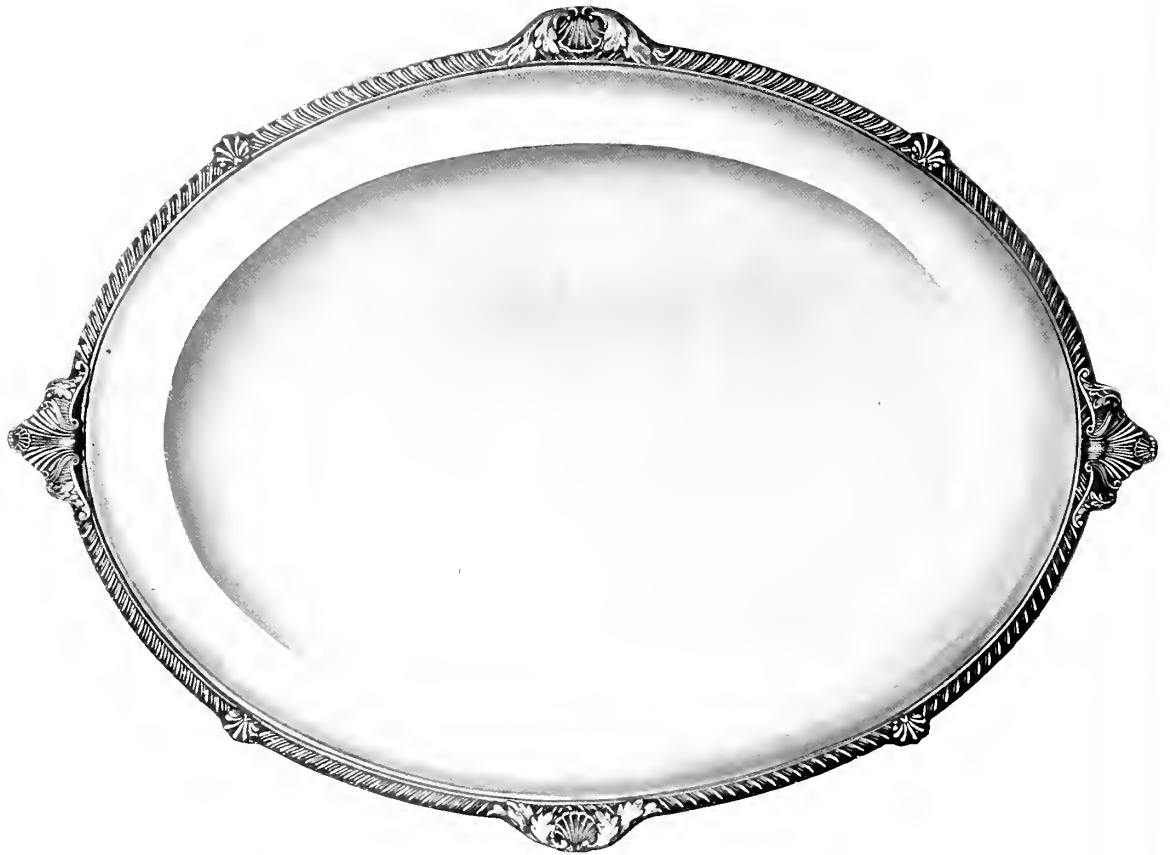

24 in. Oval Meat Plate, with gadroon and shell border, by T. & J. Creswick.
Date 1812. D. & M. Davis, Birmingham.



9 in. Plain Dinner Plate, with gadroon
border, by Watson & Bradbury.
Date 1810. Lambert, London.



8½ in. Plain Dinner Plate, with handles and well
for hot water and loose splash plate, by
M. Boulton & Co., Birmingham.
Date 1805. Author.

CRUET FRAMES AND SOY FRAMES.

Until the earliest (so far known) pattern description books of the Sheffield Plate trade again saw the light of day, it was always a subject of controversy as to where Old Sheffield platers obtained their glass in the 18th century. The article on glass which appears in the earlier part of this work (see page 67), though dealing exhaustively with this subject, yet leaves us in a condition of bewilderment as to where such immense quantities of glass could have found a market over a century ago. Without taking into consideration the glasses supplied for épergnes, liquor frames, salt cellars and mustard pots, etc., one is astonished to find that including soy frames the number of different patterns of glass cruets given on pages 196 & 197 on the books of one firm should amount to 570.

The soy frames and cruet frames—with their many combinations and varieties of patterns—are sufficiently illustrated here to give a very fair general idea of the different fashions and requirements in this branch of the industry. The name soy is borrowed from the French, and signifies sauce.



7-bottle Cruet, with silver mounted bottles, by Watson & Bradbury.

Date 1818.

Author.

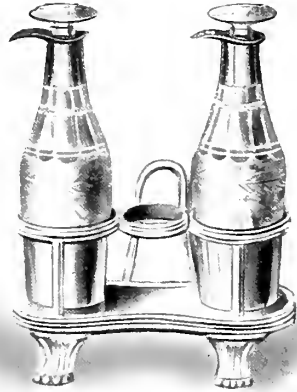

Small 2-bottle Soy Frame, by
D. Holy, Wilkinson & Co.
Date 1787. Mr. F. Hawley, London.



Small 3-bottle Soy Frame, with green bottles
ornamented with gold, by N. Smith & Co.
Date 1803. Author.

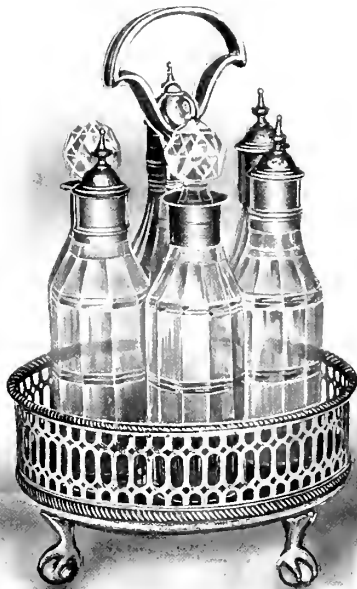

Round 6-bottle Soy Frame, by
Richard Morton.
Date 1776. Basker, Grantham.

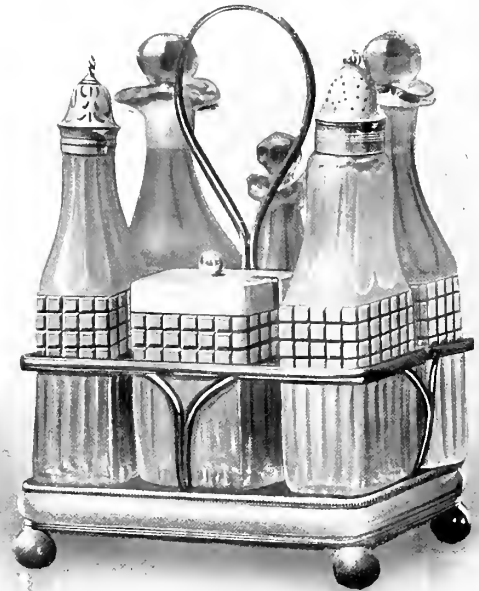

6-glass Cruet Frame, by Ashforth, Ellis & Co.
Date 1806. Paget, Cheltenham.



7-bottle Oval Soy or Cruet Frame, by T. Law & Co.
Date 1792. Cole & Son, Sherborne.

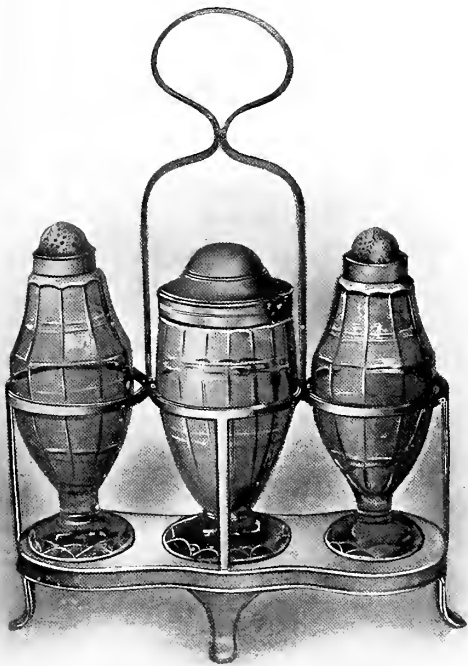

3-bottle Mustard and Pepper Combination,
by T. Law & Co.
Date 1787. Withers, Leicester.

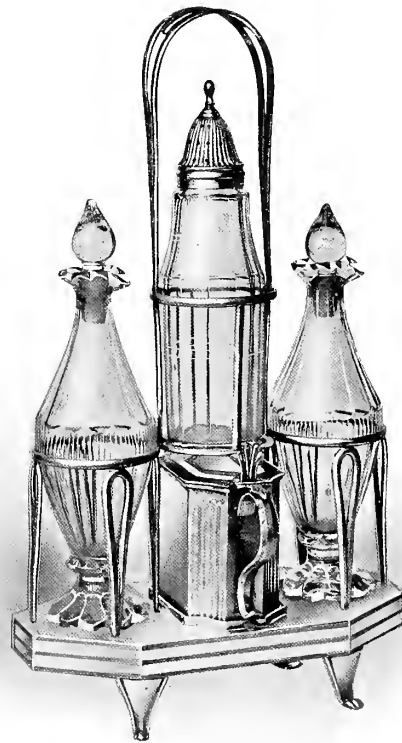

3-bottle Cruet or Soy Frame Combination, with
plated Mustard Pot, by N. Smith & Co.
Date 1789. Greenwood & Son, York.



Large 10-bottle Cruet and Pickle Frame Combination, on a revolving stand, by Watson and Bradbury.
Date 1808. Wood, Nottingham.

COMMUNION SERVICES.

A speciality of Robert Gainsford, who registered the elephant's head mark in 1808, was the making of articles in Old Sheffield Plate for sacred edifices, and about the year 1810 he issued a complete catalogue containing drawings and prices of altar candlesticks, communion cups, patens, pix boxes, ciboriums, incense burners, altar cruets, etc.

Gainsford himself was a Roman Catholic, and he appears to have received great support from this denomination in the making of articles generally for Roman Catholic churches and chapels.

In the catalogues of the other makers are only to be found here and there a few illustrations of communion services, these being plain in form and generally of the type illustrated.



Plain 1/2-pint Chalice, 6 5/8" high, by T. Law & Co. Date 1802. Author.

There are a great many plated French-made communion vessels to be found in this country. For the most part these appear to have been produced in the earlier part of the 18th century (see illustration of small altar cruet on page 168).



Plain Communion Cup, 12" high, by Robert Gainsford. Date 1810. Author.

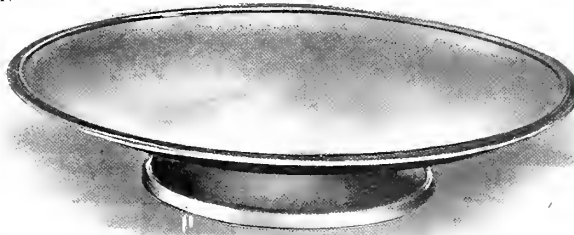

Plain Paten, on foot, 10" diam., by Robert Gainsford. Date 1810. Blackford, Lynton.



Pair 2-quart Communion Flagons, by Robert Gainsford. Date 1810. Author.

DISH RINGS, OR RIMS.

These articles, more commonly known to-day by the name of "Potato rings"—the origin of this name being to some extent a mystery—were usually punched and pierced by methods employed in the Sheffield manufactories (explained on pages 118-119). The pierced silver rings made in Ireland mostly portrayed rural subjects—shepherds and shepherdesses, farm animals, houses and cottages, hayricks, flowers, men and birds, etc., whilst the Sheffield plated rings bore flat chased scroll and festoon ornamentation, and the piercing and punchings were of the bar pattern and leaf decoration, etc. Roughly speaking dish rings may be divided into four classes, one type being chased in high relief, another in low relief, commonly called "flat chased," a third pierced and engraved, whilst the fourth consisted merely of rings made of bent wire supports fastened to a wire holder shaped to take almost any form of oval or round dish. The rings of this last class were made in a variety of ways, the commonest form being one that could be used for an oval or round dish at will by reversing the rim itself; others were made to take two different sizes of round dishes, and occasionally oval rings are found that can be treated in the same fashion (see page 282).

Mr. Westropp, in connection with the description "Irish Rings," points out that as regards the silver ones, which are always circular, they were described in the Assay Office books in Dublin as "Dish Rings," whilst in the old Sheffield catalogues they were sometimes named "Dish Rims." Having had a great number of these articles through his hands, he has never identified one as being made previously to the year 1750. He has found them mentioned in auction advertisements in old Dublin papers as follows:—1762, "a Dish Stand;" 1776, "a Ring for a table;" 1780, "a Ring for the centre of the table."

So far none of the old Sheffield plated catalogues, issued for general trade purposes, have disclosed any illustrations of the so-called Irish styles or shapes of pierced dish rings. This fact would naturally lead to the conclusion that they were articles made exclusively for the Irish market.

Illustrations are given on subsequent pages of so-called Irish dish rings, three of which are the property of Mr. L. A. West, of Dublin. Mr. West's own notes on these articles will be valued, as he has taken considerable interest in the subject. He says: "These rings are now generally supposed to have been made as stands for china punch bowls, thus serving the double purpose of raising the bowls so as to display them better, and also of preventing them from damaging the mahogany, many people refusing to entertain

the originally accepted idea that they were ever used as stands for wooden potato bowls. Personally I believe they were employed in both capacities, as in such case they were being used during the greater part of the dinner, and certainly they formed most beautiful table ornaments. I fancy these rings would be made about the same time as Old Sheffield Plate came into vogue. I once had a pair of old Sheffield dish rings chased in high relief, but the ornamentation consisted of scrolls, foliage, and floral decoration generally, and was not of the peculiarly Irish farm-yard kind to be found in silver, of which latter type I have seen but one old Sheffield ring."

Mr. West's view is that all the Old Sheffield Plate rings were actually made in Sheffield, and this is confirmed by illustrations given in this volume of other pierced plated articles of Sheffield manufacture carrying the same style of decoration. From the duplicate silver salts, baskets, etc., found in solid silver, it has also been possible to identify the Sheffield makers and the approximate dates of the manufacture of some of the rings (see page 280).

HOW THE DISH RINGS WERE MADE.

The process adopted for the manufacture of Sheffield Plated Dish Rings was as follows :—

Having taken a sheet of fused metal, plated on both sides, about 18 to 20 inches in length by from $4\frac{1}{2}$ to 5 inches in breadth, the workman would turn it up and solder it together in cylinder form, after which he carefully hammered it into a crescent shape on a wooden block designed for the purpose, slightly larger at one end than the other. Then, having by this method obtained a ring of the required shape, i.e., slightly tapering away towards one end, he finally re-hammered it on a steel stake until the necessary smoothness was obtained.

The next process was the decoration, which in the case of Sheffield plated rings was performed by the aid of a bed and punch under a fly ; in other words, the pattern was actually pressed on in this manner. After this, the services of the fly-piercing and punching machine were requisitioned to press out the open-work in the pattern (see illustration, page 119). Now the ring was ready for mounting, and this was accomplished by soldering on a light stamped silver mount, either thread, bead, or ogee, in keeping with the style of the pattern of the ring, the fash of the mount being lapped over the outer edge of the ring so as to form a protection. After careful burnishing and hand polishing, the ring was ready for use.



Pierced and Chased Dish Ring, size $3\frac{3}{4}$ in. high \times $7\frac{5}{16}$ in. diameter, showing a popular pattern in silver, made in Dublin, by Wm. Townsend,
 Date about 1770. The Irish National Museum, Dublin.



Reverse side of Silver Dish Ring.



Sheffield Plated Dish Ring, size 3 in. high \times $7\frac{3}{4}$ in. diameter, chased in the Irish style.
 Date 1765-1770. Franklin & Hare, Taunton.



Reverse of Sheffield Plated Dish Ring.



Sheffield Plated Dish Ring,
evidently a replica of an
Irish-made Silver Ring.
Date 1773—1783.
West & Son, Dublin.

Sheffield Plated Oval Dish Ring,
size $3\frac{1}{2}$ in. high \times $8\frac{1}{2}$ in. in length,
with machine piercing and
pressed decoration.

Date 1780—1785. Author.



Sheffield Plated Dish Ring,
size $3\frac{1}{2}$ in. high \times $7\frac{5}{8}$ in.
diameter, with the mount
turned over a wire for
strengthening purposes.

Date 1773—1783.

Elkington & Co., London.





Sheffield Plated Dish Ring, size 4 in. high \times 7 $\frac{3}{8}$ in. diameter, with machine piercing and flat chasing, by D. Holy, Wilkinson & Co.
 Date 1785. Elkington & Co., London.

Silver Salt Cellar, Sheffield hall mark
 1787, by Tudor & Leader.



The piercing shows that the same tools have been used as when decorating Ring shown below.



Sheffield Plated Dish Ring, size 4 in. high \times 7 $\frac{1}{2}$ in. diameter, with machine piercing and pressed ornament, by Tudor & Leader.
 Date 1787. West & Son, Dublin.



Sheffield Plated Dish Ring, size $3\frac{3}{4}$ in. high \times $8\frac{3}{4}$ in. diameter, with machine piercing and flat chasing, by R. Morton & Co. West & Son, Dublin.

Date 1780—1790.



Sheffield Plated Dish Ring, size 4 in. high \times $8\frac{1}{2}$ in. diameter, with machine piercing and pressed flutes. L. Wine, Dublin.

Date 1786.



Dish Rim, used as holder for cut-glass dessert dish, oval form, for two sizes.
Date 1795. Author.

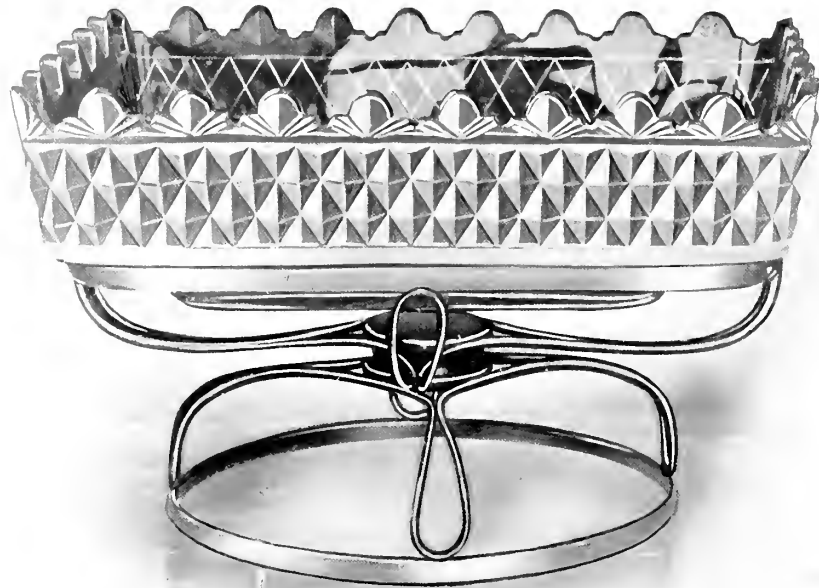

Dish Rim, used as holder for cut-glass dessert dish, round or oblong.
Date 1800. Author.

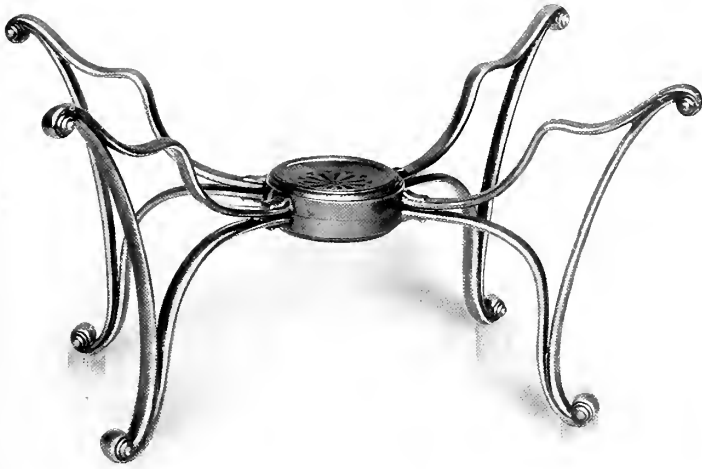

Folding Dish Cross or Holder, by
Roberts, Cadman & Co.
Date 1807. Author.

Folding Dish Rim or Holder, by
Watson & Bradbury.
Date 1810. Spink & Son,
London.

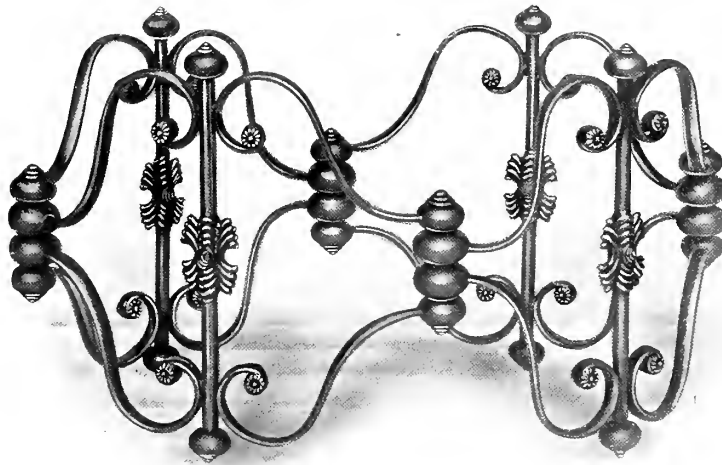

DISHES FOR ENTRÉES, ETC.

The most important articles for table use in the olden days were undoubtedly entrée dishes, and when the old plating trade was in the hey-day of its prosperity, their varieties and forms were innumerable. As we know them to-day, they were only occasionally made before the year 1785, and were very rarely manufactured at all before 1775. The handles of the earliest entrée dishes are usually at the ends and not on the covers. In the books that date back to the 18th century they were described as "double dishes," "steak dishes" and "hash dishes," the latter being made with stands, both with and without lamps for heating purposes. Usually the entrée dish was accompanied by a "warmer," the earlier forms of which were heated by a red hot iron deposited on a metal framework

in the base. The upper lid of warmer on which the dish rested was perforated (see illustration, page 289). Then followed the method of fitting the dish inside a warmer containing hot water without the aid of a heating iron (see page 286). Innumerable varieties of separate dishes were made for serving pies and jellies, though the lower halves of entrée dishes were also used for such purposes. Vegetable dishes were usually in a round form, with an outer jacket for hot water. The handle unscrewed, and the hot water was poured down the hollow tube. Others were fitted with a screw plug for this purpose, whilst the dish itself was divided into three divisions with a removable partition (see page 288).

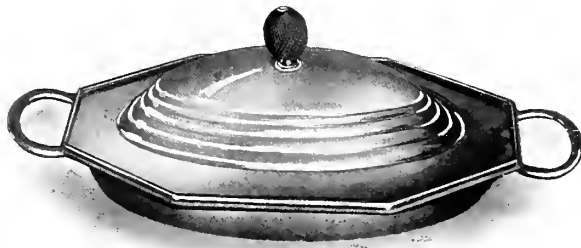

An early form of Entrée or Hash Dish and Cover, by
T. Law & Co. Davis, Manchester.
Date 1778.



Entrée or Hash Dish and Cover, with upright handles,
by D. Holy, Wilkinson & Co. Withers, Leicester.
Date 1789.



Entrée Dish, with Cover, to be used as two separate
dishes, by N. Smith & Co. Chapple & Mantell, London.
Date 1790.

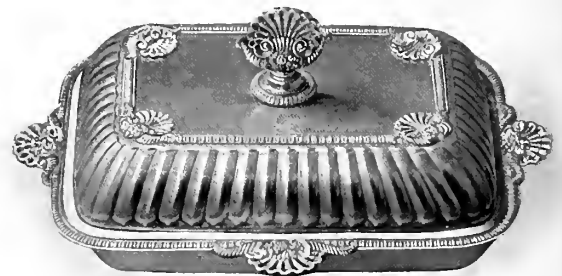

Gadroon and Shell Entrée Dish, with Fluted Cover, by
Watson & Bradbury. Hunt, Preston.
Date 1810.

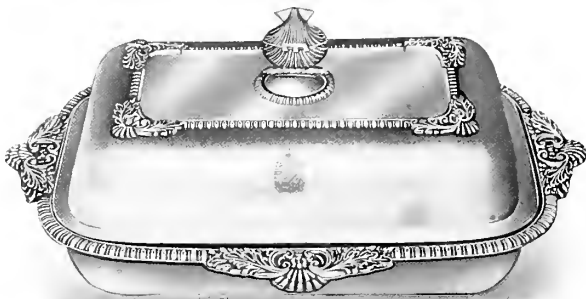

Entrée Dish, with shell crest as handle, and gadroon and shell
mounts, by Tucker, Fenton & Co. Mr. W. P. Belk, Sheffield.
Date 1810.

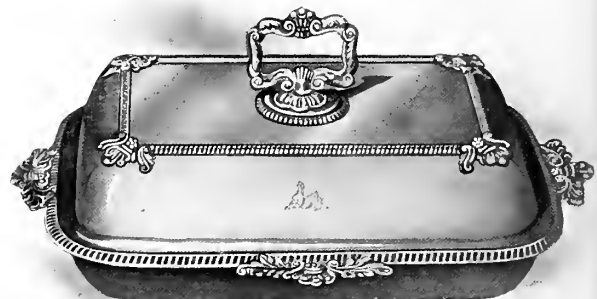

Plain Entrée Dish, with lightly ornate French gadroon mount,
by Tucker, Fenton & Co. Author.
Date 1812.

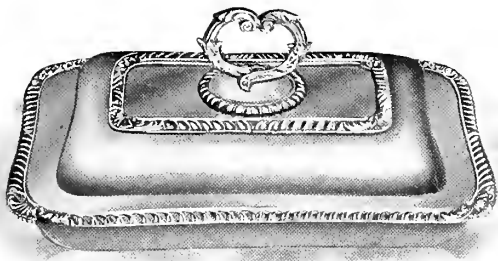

Oblong Gadroon and Shell Entrée Dish, by
Watson & Bradbury.

Date 1812.

Author.



Oblong Oak Shell and Gadroon Entrée Dish, by
Watson & Bradbury.

Date 1816.

Elkington & Co., London.

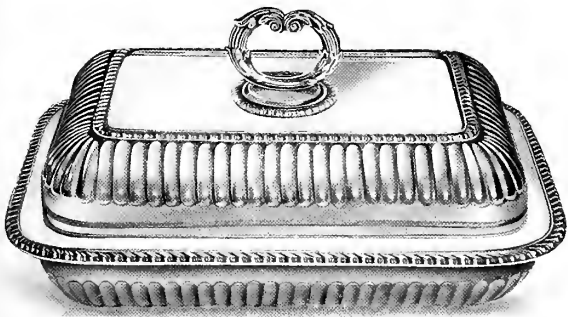

Oblong Fluted Entrée Dish and Cover, by
M. Boulton & Co., Birmingham.

Date 1809.

D. & M. Davis, Birmingham.

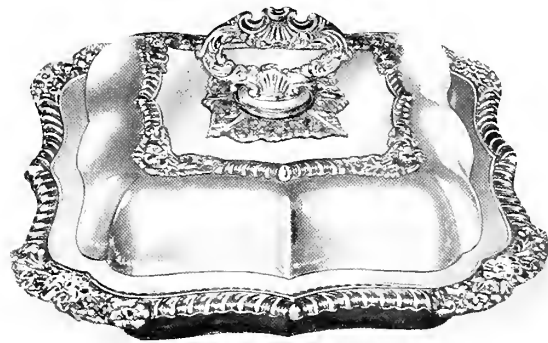

Shaped Gadroon Square Entrée Dish, with rose ornament
at corners, by Gainsford & Nicholson.

Date 1817.

Lambert, London.

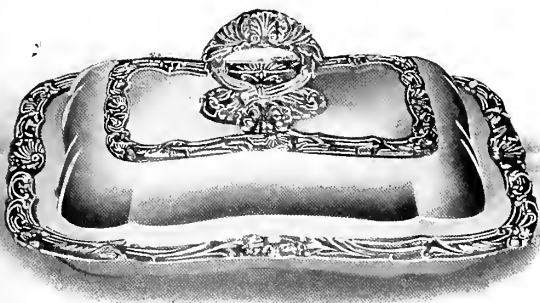

Reid's Mount Oblong Entrée Dish, by
Watson & Bradbury.

Date 1828.

Author.

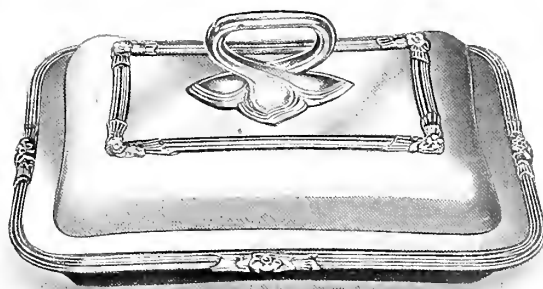

Thread and Rosette Mount Entrée Dish, by
Watson & Bradbury.

Date 1830.

Lambert, London.



Oblong full size Gadroon and Shell
Entrée Dish and Warmer, by
T. & J. Creswick.
Date 1818. Robinson & Co.,
Shrewsbury.

Oblong full size Gadroon and
Shell Entrée Dish and Warmer,
by Watson & Bradbury.
Date 1818. Sir T. Freake,
Monmouth.



Very large Entrée Dish and
Warmer, (13½ in. long.)
mounted with gadroon and
flowers, by Kirkby, Water-
house & Co.
Date 1820. Author.



Round Gadroon and Shell Border, with
Mask Handle Supports, Second Course
Dish and Warmer, 12 in. diameter, by
M. Boulton & Co., Birmingham.
Date 1815. D. & M. Davis, Birmingham.

Round Gadroon, Shell and Leaf Border
Second Course Dish and Warmer, 11½ in.
diameter, with Fluted Cover, by D. & G.
Holy & Co.
Date 1817. Wilson & Sharp, Edinbro'.



Round Scroll and Leaf Border Second Course
Dish and Warmer, 10½ in. diameter, by
Gainsford & Nicholson.
Date 1817. Lambert, London.

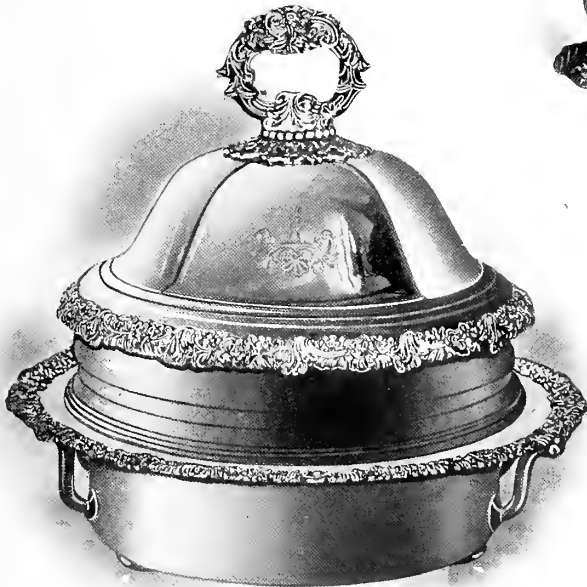



8 in. Round Gadroon Second Course Dish and Warmer,
by M. Boulton & Co., Birmingham.
Date 1810. D. & M. Davis, Birmingham.

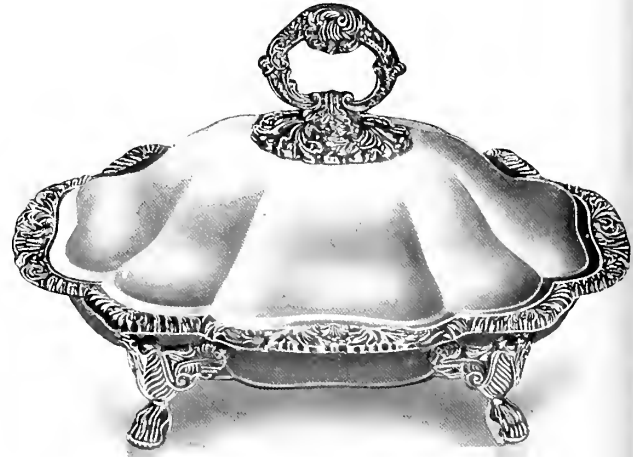

Oblong Hash Dish, 13½ in. long, with strainer and
fluted cover, gadroon and shell border, by
Watson & Bradbury.

Date 1817.

Author.



3-division Vegetable Dish, with handle made to unscrew, down which hot water can be poured
into the jacket which surrounds the dish, by G. Ashforth & Co.
Date 1818. Withers, Leicester.

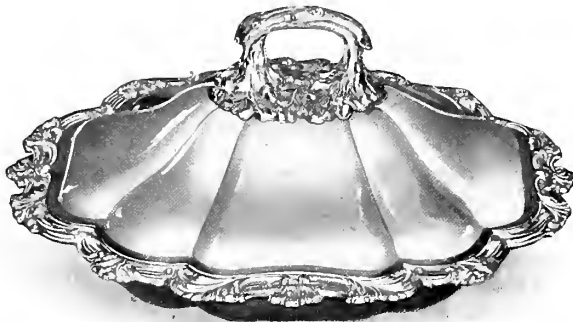

Oblong Fluted Cover Steak or Vegetable Dish, 13½ in.
long, scroll mount, by Kirkby, Waterhouse & Co.
Date 1825. Butt & Co., Chester.



Oval Scroll Mount Pie Dish, 12 in. long, by
Watson & Bradbury.
Date 1820. Author.

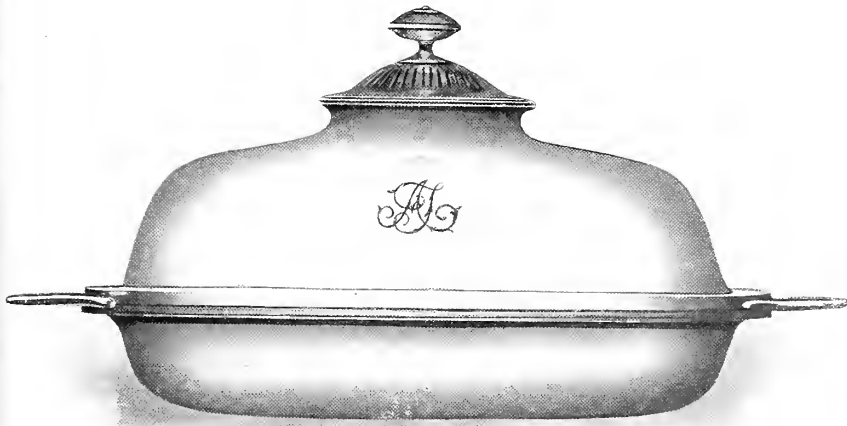

14 in. Oval Hash or Fowl Dish, with domed cover, for use on a dish cross, by J. Younge & Co.
Date 1782. Leighton, Lancaster.

12 in. Gadroon Entrée Dish and Warmer, with metal handles, by Blagden, Hodgson & Co.
Hall & Co.,
Date 1817. Manchester.

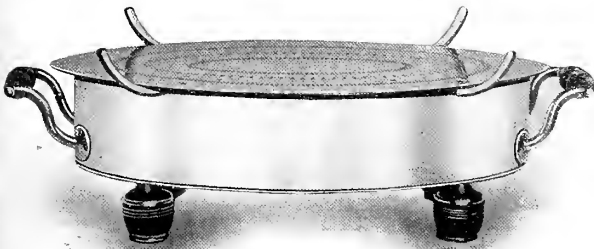
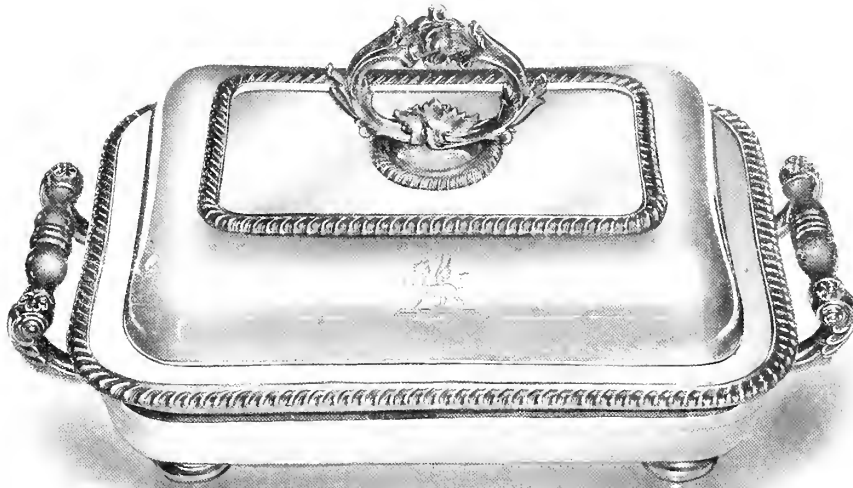

Oval Entrée Dish Warmer, with heater and pierced top, by J. Younge & Co.
Date 1785. Hardcastle, York



Round Pierced Dish Warmer, with heater, by I. & I. Waterhouse & Co.
Date 1830. Reed, Liverpool

ÉPERGNES AND PLATEAUX.

Perhaps the triumph of the Old Sheffield Plate trade was the production of the wonderful combinations of centre and side dishes, surrounded by muffineers, mustards, salts and cruet bottles, complete on a revolving stand. They seem to have been immensely popular towards the latter end of the 18th century; and as "Épergnes," pride of place is given to them in Sketchley's 1774 list of productions, given on page 196 of this book.

The remains (as one may term them) of these early delicately fashioned centre pieces in existence to-day are almost beyond hope of repair. Very few are to be found complete, and certainly no latter-day domestic servant could handle such combinations of glass and wire material without their suffering severely (see page 291). How they managed to deal with them in the olden days is a mystery, but evidently people would have them. The cost of these centre pieces, too, was high, by comparison, their average being from 15 to 21 guineas each wholesale.

We next come to the late 18th and early 19th century épergnes of wire-work on a revolving stand, to hold fruit and flowers. These always come in for a word of praise from connoisseurs. Their delicately shaped stems revolve on a pivot fixed in a socket towards their base and support as a rule from five to eight baskets, all of which can be detached and used as separate receptacles for sweetmeats or for other purposes (see pages 292, 293).

The last form of Old Sheffield centre-piece was a veritable triumph of cut glass and heavy floral decoration. These late Georgian épergnes are most striking objects when displayed on the dinner table piled with fruit or flowers. As regards the artistic appearance of the latest of the Old Sheffield productions, it would be unfair to write without giving some meed of praise to the workmen who produced them. Their various parts are so beautifully united that the joining of the seams can only be detected by technical experts. A very high place must be given to them as fine achievements of the industry (see pages 294-5-6).

Generally these épergnes are found—unless they have been used in hotels—in perfect condition, as on account of the immense amount of cleaning required, they were only on special occasions brought out for use. Unfortunately, however, they are too often useless from both an artistic and practical point of view, through the absence of their crystals. An épergne without its glasses presents as pitiable a spectacle as a sailing vessel which has weathered a storm but has lost its masts and sails.

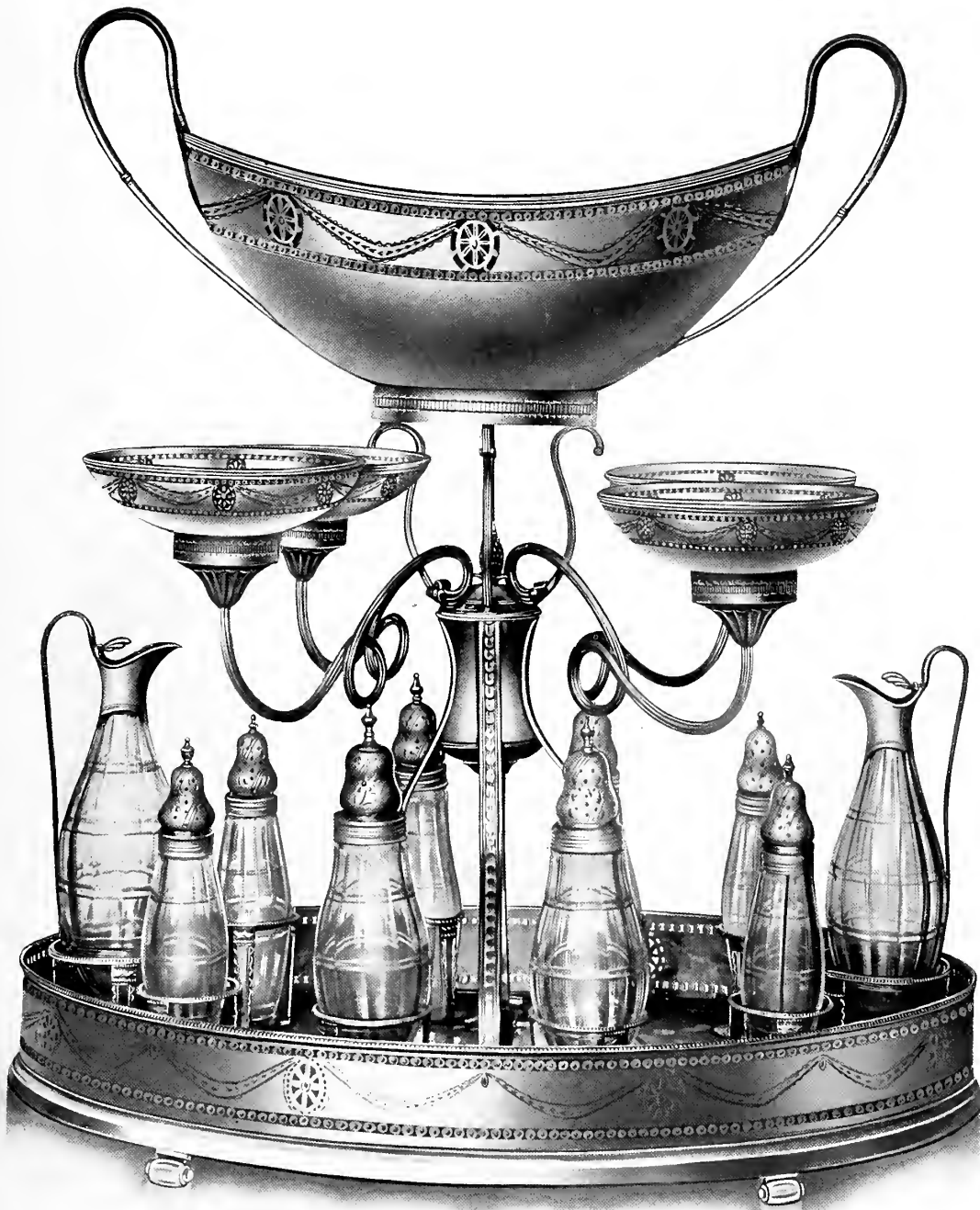

Pierced Epergne, 21 in. high \times 17 in. This centre piece has been reconstructed. Originally manufactured in the year 1777, by 1911 one cruet bottle only out of ten remained intact. The wire supports and one handle of the basket were badly broken, but the hall marks on two of the silver tops to bottles disclosed the identity of the maker, and the date of manufacture. By Richard Morton & Co.

Date 1777.

West & Son, Dublin.



6-arm Epergne, 18 in. high, with centre dishes and glasses complete, by Roberts,
Cadman & Co. Mr. S. Roberts, M.P., Sheffield.

Date 1785.



Revolving Epergne, 21 in. high, with nine bowls and drawn wire arms. The base adapted from a candlestick, by Richard Morton & Co.

Date 1790.

Mr. D. Vickers, London.

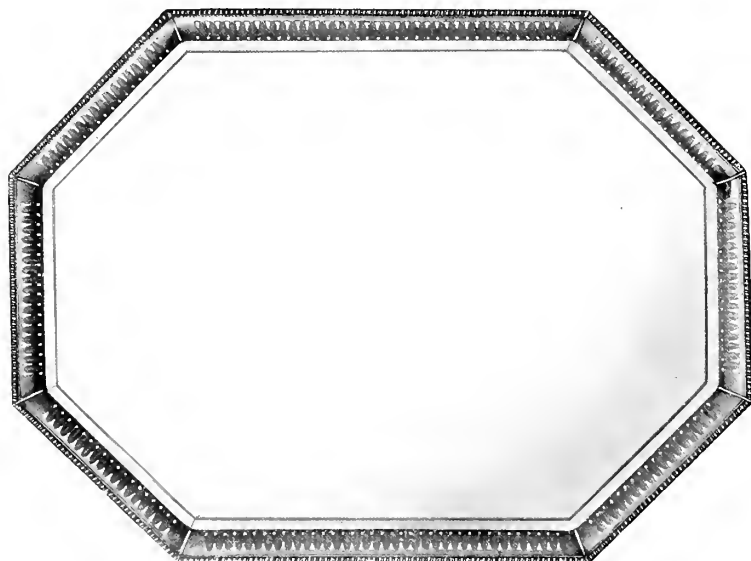

22 in. Plateau, with looking glass bottom and pierced border, by G. Ashforth & Co.
Date 1789. Mr. W. J. Fieldhouse, Wootton Waven.



5-glass Epergne, 16½ in. high, with caryatides figure support, on plateau, by Roberts, Cadman & Co.
Date 1822. Butt & Co., Chester



Dessert Stand and Plateau, 22 in. high, with caryatides figures and egg and
dart mouldings, by I. & I. Waterhouse & Co.

Date 1833.

Mr. T. P. Barker, Four Oaks.

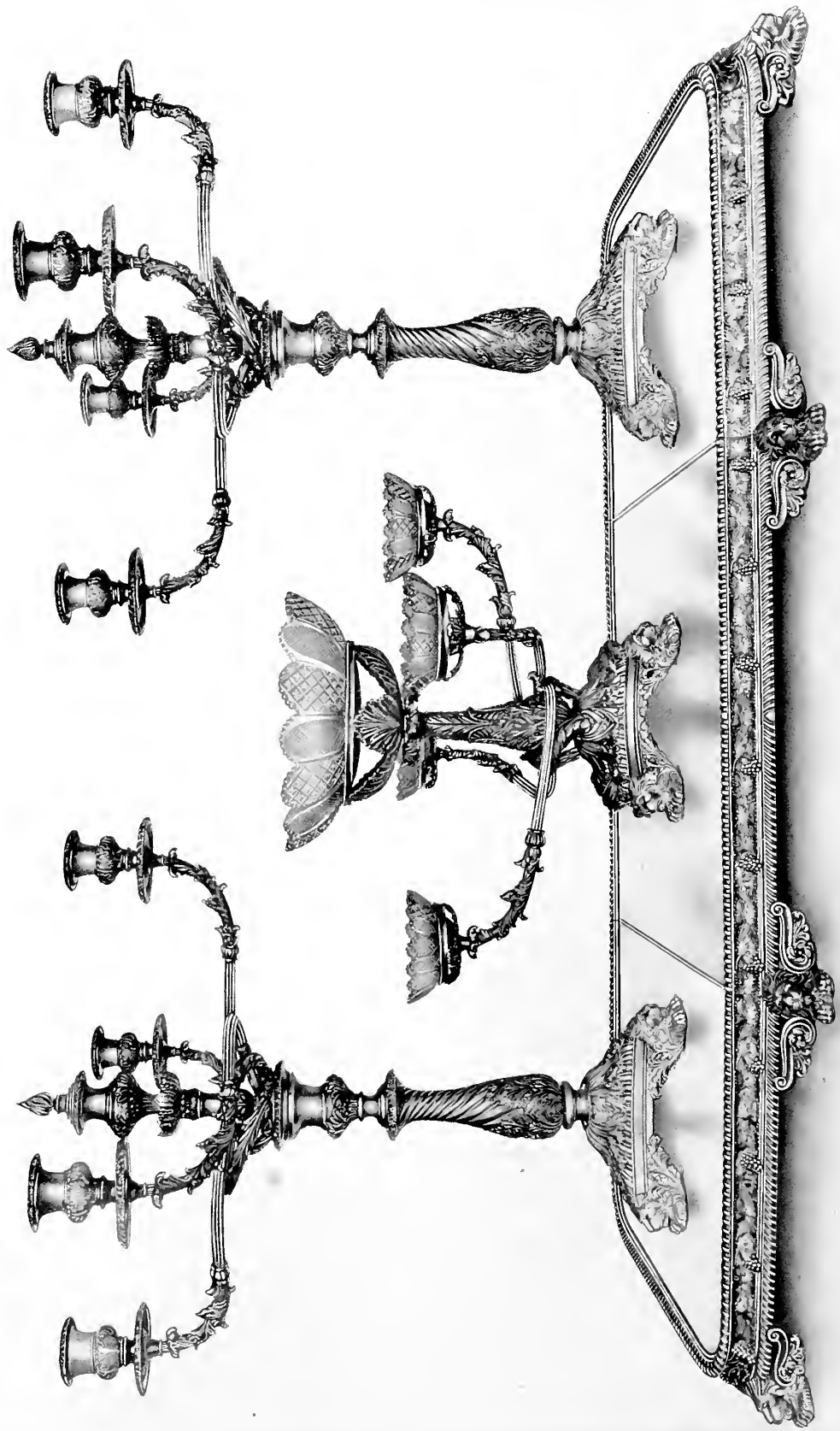

Pair Candelabra, 27 in. high; Epergne, 16½ in. high; Plateau—in three sections—50 in. long, by T. J. & N. Creswick.

Date 1820.

Author.

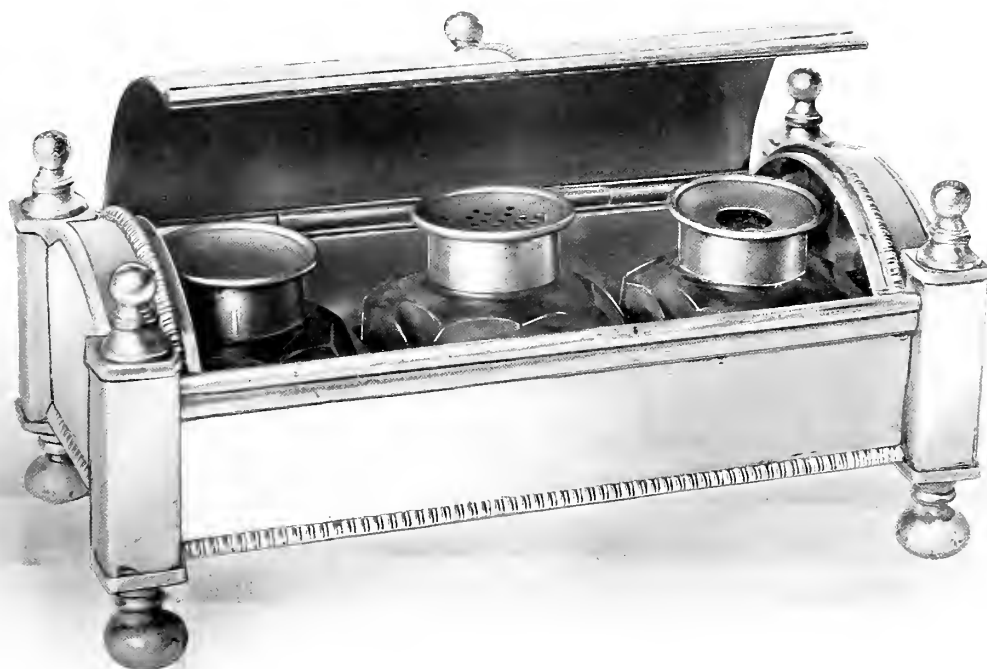

3-bottle Oblong Inkstand, $6\frac{1}{4}$ in. \times 3 in. high, with hinged lid and domed cover, by Tucker, Fenton & Co.
Date 1803. Mr. B. B. Harrison, Sevenoaks.

INK STANDS.

The first attempts made by the Sheffield platers in the making of inkstands brings home to us very clearly the influence in design taken from the contemporary London silversmiths in the earliest periods of the industry. These lightly made inkstands, with perforated bodies and long curved chased scroll decoration, are extremely scarce. Their disappearance is due to the fact that being made previous to the using of plated wire or silver edges, they lacked the protection necessary for articles subjected to exceptionally hard wear.

Lord Nelson was an admirer of Old Sheffield Plate, and there is said to be still in existence an inkstand that he used at the battle of Copenhagen in the year 1801. It was presented by him to Captain James Clarke after the battle as a memento.*

On next page will be seen a little inkstand, with handle in form of an anchor, bearing the mark of D. Holy, Parker & Co., made about the year 1804. It has been stated that this inkstand also was once the property of, and made for, Lord Nelson. But although a small article, not unlikely to be found on

* For further information see the *Connoisseur* for April, 1904, page 253, and May 1904, page 54. This inkstand is said now to be in the possession of Dr. C. M. Clarke.

board an old man-of-war, it is more probable that the design owed its influence to the victories achieved by Lord Nelson about this period. As hitherto no duplicate has come to light, presumably the pattern was not put upon the market in the regular way.

Amongst other things offered for sale about the date of the purchase of this inkstand (1895) were a set of four Old Sheffield entrée dishes bearing Lord Nelson's crest, with many other relics, both silver and plated, now in public institutions and private hands, including the celebrated Flaxman-Nelson vase in silver-gilt, formerly the property of the late King Edward VII.*



Unusual form of small pierced 2-bottle Inkstand, 7 in. long, with centre taper which has side handles, by J. Parsons & Co. (A similar inkstand is illustrated in an old plater's catalogue now the property of the Irish National Museum.)
Date 1784. Author.

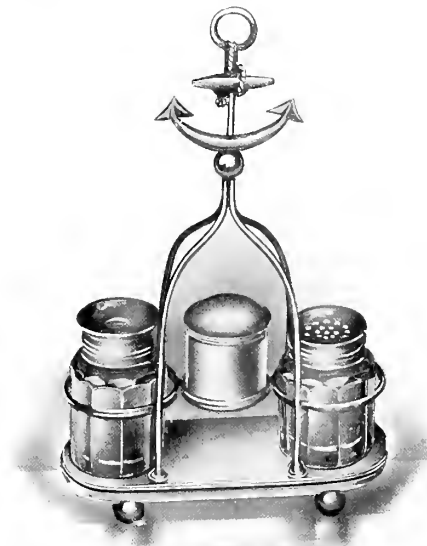

The Victory Inkstand, with 2-bottles and wafer box, 8 in. high, by Danl. Holy, Parker & Co.
Date 1804. Author.



The Pitt or Globe Inkstand, 9 in. high, with revolving cover, by Roberts, Cadman & Co.
Date 1810. Mr. B. B. Harrison, Sevenoaks.

* Purchased by him when Prince of Wales from E. & E. Emanuel, The Hard, Portsea.

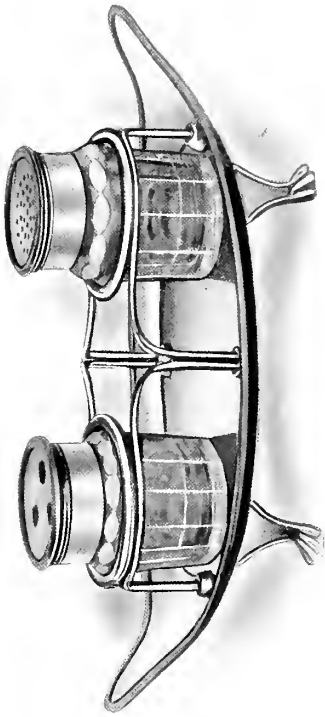

2-bottle Oval Inkstand, wire-work supports, by D. Holy, Wilkinson & Co.
D. & M. Davis, Birmingham.
Date 1795.

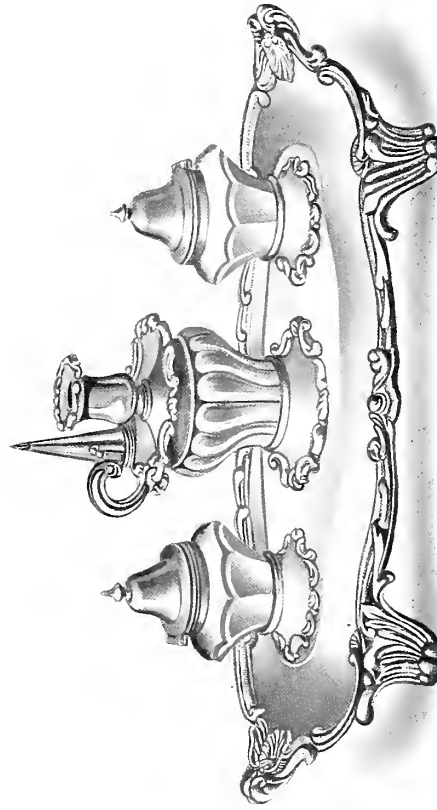

2-bottle Inkstand, with wafer box and taper stick, by Gainsford & Nicholson.
Mr. A. Nicholson, Sheffield.
Date 1835.

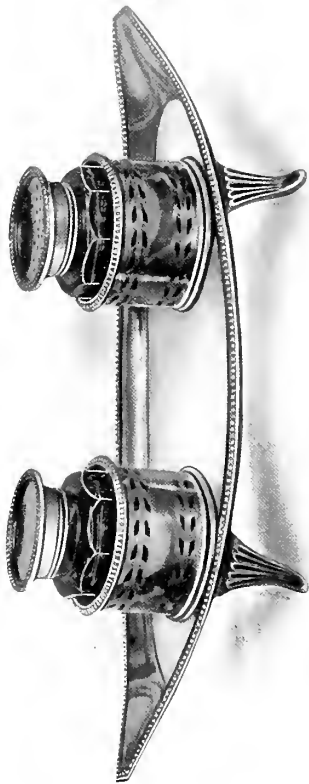

2-bottle Oval Pierced Inkstand, by N. Smith & Co.
Author.
Date 1789.

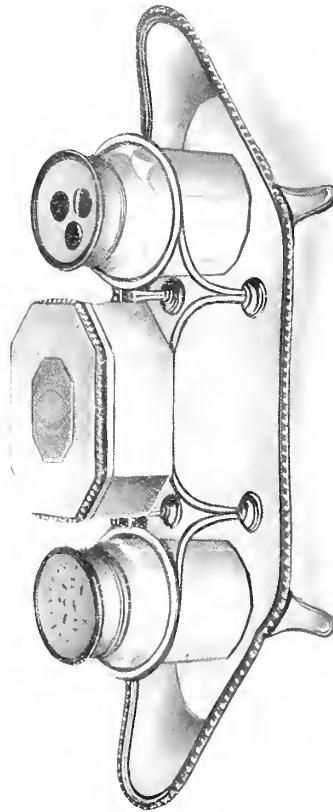

2-bottle Oval Inkstand, with wafer box, by Watson & Bradbury.
Simmonds, Monmouth.
Date 1798.

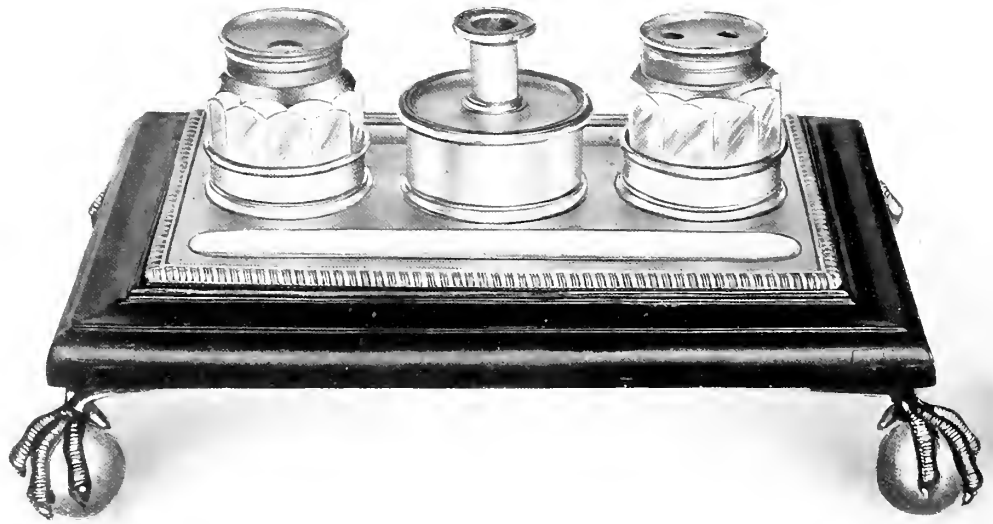

2-bottle Inkstand, with wafer box and taper stick, fitted into a wooden stand.
Date 1789. Withers, Leicester.



Large 2-bottle Inkstand, with wafer box and taper stick, by T. J. & N. Creswick.
Date 1825. Robinson & Co., Shrewsbury.

KETTLES ON STANDS, WITH LAMPS.

Kettles are not very numerous in Old Sheffield Plate. Only six different patterns are given in the old lists of goods in the earlier book referred to on page 197, but in the subsequent pattern books compiled between the years 1815 and 1830 this number is increased to 10.



5-quart Kettle and Stand, by Roberts, Smith & Co.
Date 1828. Mr. S. Roberts, M.P., Sheffield.



3-quart Kettle and Stand, with light gadroon mounts
and fluted body, by Watson & Bradbury.

Date 1798.

Lake & Son, Exeter.



5 pint Kettle and Stand, with light gadroon mount
and plain body, by Watson & Bradbury.

Date 1795.

Mr. H. C. Casley, Ipswich.

LABELS FOR DECANTERS, ETC.



Date 1815.

Decanter Labels, by Watson & Bradbury.

Author.



Date 1810.

Decanter Labels, by N. Smith & Co.

Author.

LIQUOR FRAMES.

Although 328 varieties of liquor frames are to be found indexed with the other articles in the lists of patterns given on page 197 as in use a century ago, showing the enormous demand there must have been for gin, hollands, rum, and other curious drinks then in vogue (to which the wine labels illustrated on previous page testify) it cannot be said that to-day any demand exists for them; and perhaps the same remark holds good in a modified form to cruets and other combinations of glass with silver, and glass with plate. Whether



Small Liqueur Frame, with two 1-pint bottles and two tumblers, in pierced stand, by J. Younge & Co.
Date 1783. Hunt, Preston.



Liquor Frame, with three 1-quart blue coloured bottles and gilt lettering, by Watson and Bradbury.
Date 1812. Author.

it be in Old Sheffield or antique silver, any article where the glass assumes too prominent a feature in its structure is not sought after to-day, either by collector or public. Liquor frames and cruet frames can at the present time be procured at one-tenth of the prices that obtain for the more general and more popular varieties of articles both in antique silver and Old Sheffield Plate.

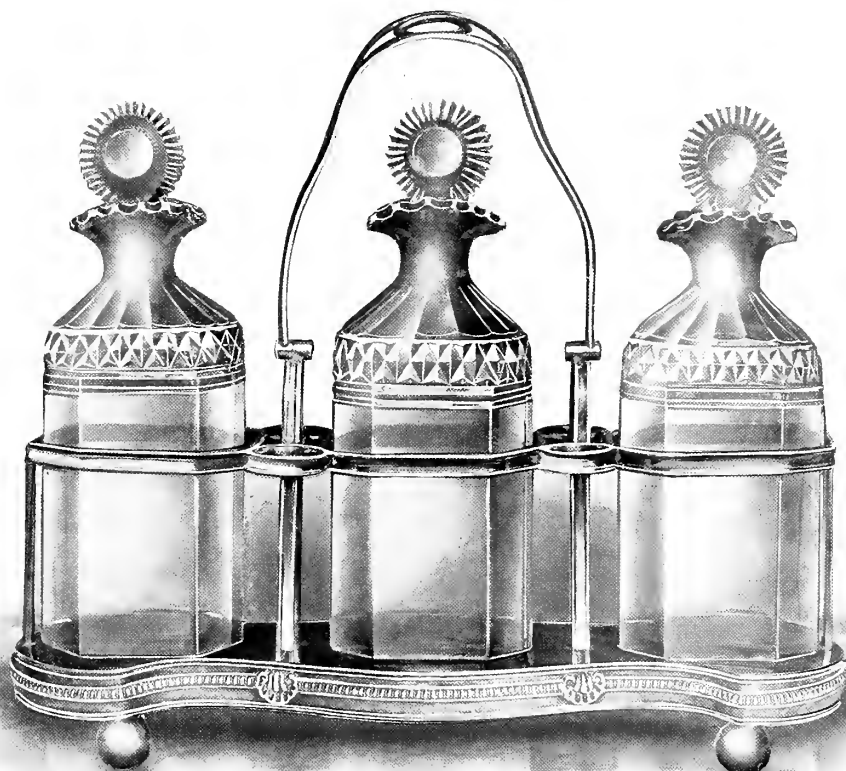

Liquor Frame, with 3 bottles, by Watson & Bradbury (formerly the property of Thomas Bradbury).

Date 1803.

Author.

PITCHERS OR JUGS.

By no means the least useful, and certainly the most graceful, articles of fused plated ware are the jugs made by the Old Sheffield platers. They are not, however, very plentiful, and as a consequence the prices now obtained for good specimens are relatively high. "Pitchers" are the designations given to them in the old number books of the trade from the earliest times. A well made and shaped pitcher is an article that perhaps as much as any other lends itself to the decorative ornament prevalent between the years 1770 and 1790. This fact seems to have been realised fully as much by the master potters of this period as by the Sheffield platers. The contemporary silversmiths were, however, somewhat behind-hand in their productions of pitchers in solid silver. These appear to have died out in old plate with the advent of the "Biggin," which could be used either for coffee, milk, water or cocoa. Illustrations are given on next page of large negus or claret jugs, very rarely to be met with to-day.



2 $\frac{3}{4}$ -quart "Hebe" Jug, chased band and fluted base, by Goodman,
Gainsford & Fairbairn.
Date 1797.
Lambert, London.

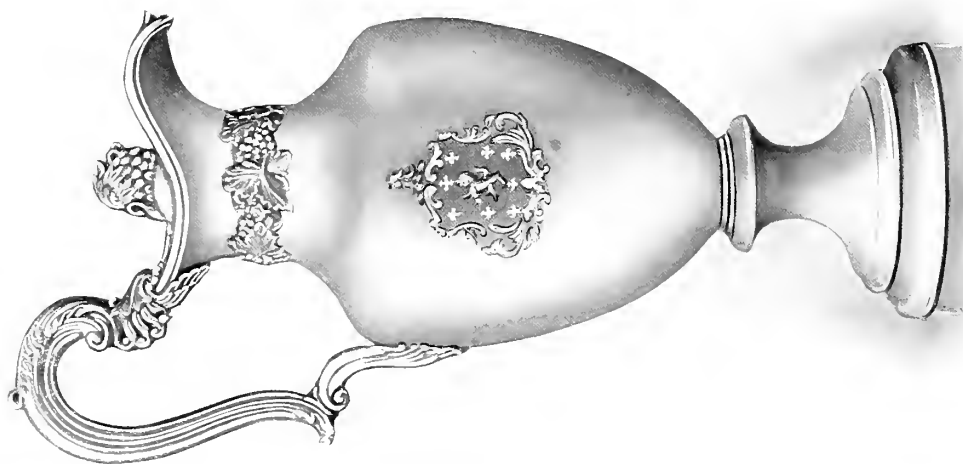

2-quart Negus or Claret Jug, by Roberts, Smith & Co.
Date 1828.
Mr. H. C. Casley, Ipswich.

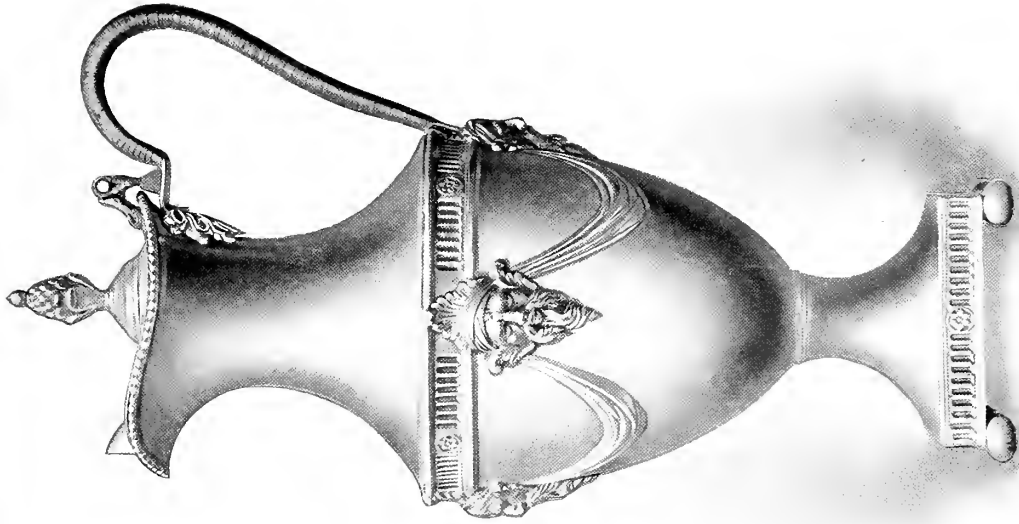

1-quart Adam Jug, with draped mask head decoration, by R. Merton & Co. Author. Date 1773.

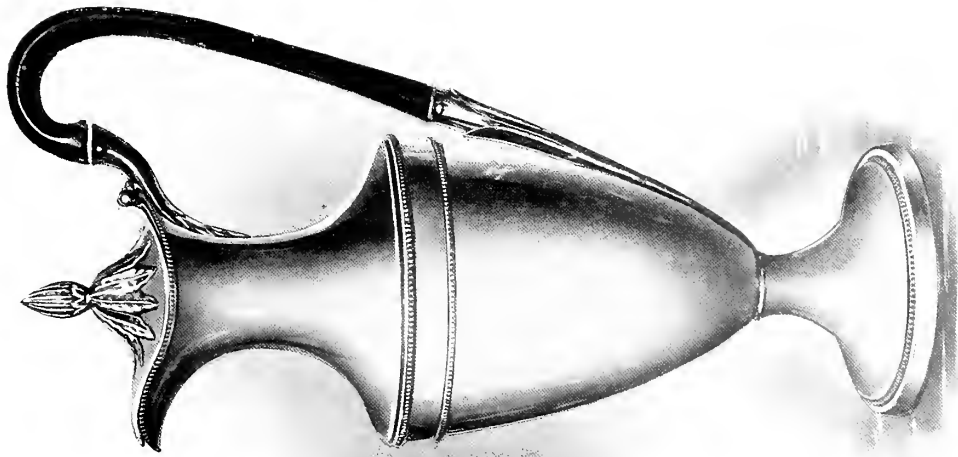

1-quart Jug, with bead mounts, by J. Younge & Co. Date 1783. Robinson & Co., Shrewsbury.



1½-pint Adam Jug, with festoon ornament, by
J. Hoyland & Co.
Date 1778. Ince, Newport.



1½-pint Adam Jug, by Matthew Fenton & Co.
Date 1777. D. & M. Davis, Birmingham.



1½-pint Adam Jug, with festoon chasing, by
Tudor & Leader.
Date 1775. Ince, Newport.



1¾-pint Jug, with lightly chased body, and fluted
base, by D. Holy, Wilkinson & Co.
Date 1782. Mr. A. J. Hobson, Sheffield.

SALT CELLARS, MUSTARD POTS, AND PEPPER POTS (OR MUFFINEERS).

Of the articles that have continued in constant daily use from the earliest records of the plating industry down to the present time, prominence must be given to salt cellars and mustard pots. It will be noticed that one hundred and thirty-eight of the former, and sixty-five of the latter, in different patterns are listed on page 197 in the extracts from the old pattern book. Salt cellars of the George III. period always command high prices when brought under the hammer, whether in Old Sheffield Plate or antique silver, whilst mustard pots have lately reached almost prohibitive figures. As is usual with both antique silver and Old Sheffield Plate of this period, the pierced varieties of these articles are those most sought after by connoisseurs. If in anything like good preservation, it is very difficult to distinguish between the plated and the silver examples.

Almost as many pierced salt cellars and mustard pots seem to have been made by the Sheffield platers in solid silver as in plate. Being perhaps cheaper than the silver salts and pots made in London (on account of the labour-saving methods of piercing adopted), it seems likely that the Sheffield manufacturers had a larger market for these articles than the London silversmiths. A form of salt cellar with wire supports, gilt plate, and large heavy cut glass containers appears to have been peculiar to Sheffield, both in Sheffield plate and silver, from the earlier part of the 19th century until the termination of the industry (see pages 313 and 415).

The round 3-legged salt cellar illustrated on next page, though small, is one of the most interesting pieces of Old Sheffield Plate that has so far come to light, for the following reasons:—

The initials H.T. (used by Tudor & Leader), repeated three times (one punch mark having been obliterated by the repairer) clearly shows that the article was made before the year 1773, in which year an Act was passed forbidding such marking, as too nearly resembling the contemporary silver hall marks (see Part X).

The article having undoubtedly been made from fused plate, plated back and front, disposes of the contention (as the salt has not subsequently been electro plated) that the plating on both sides of the ingot was not discovered until about the year 1803.*

The body has been shaped up by hand, giving it great strength and rigidity. The festoon ornamentation has been struck from a separate die and fastened on with solder.

* Further particulars concerning this subject will be found on page 75.

The raised escalated mount, also soldered on separately, has been struck up from a die and duplicated, for strength.

The feet have been stamped from two separate dies, back and front, and soldered together, having first been filled with tin and lead.

This salt cellar has had a very great deal of wear and the salt has corroded through the metal in two places, where it has been repaired with a small patch of silver in each case. All its features follow so closely the lines of the three-legged silver salts made in London about the years 1760-70, as to point to the conclusion that it has been made by a silversmith trained in that city.



3-legged Salt Cellar, $2\frac{1}{2}$ in. across top, by
Tudor & Leader.
Date 1765. Mr. R. E. Leader.

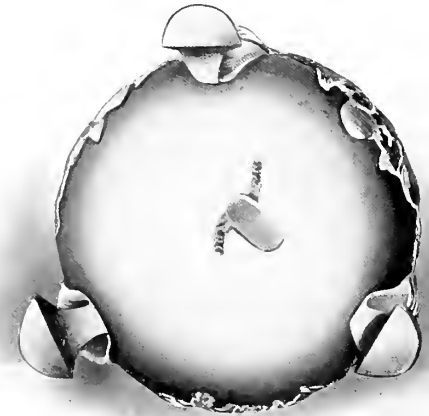

Reverse side of Salt Cellar, showing maker's initials
partly covered by a patch, owing to repairs.



Pierced Salt, by R. Morton & Co.
Date 1775. Author.



Pierced and Chased Salt, by R. Morton & Co.
Date 1780. Lake & Son, Exeter.



Octagonal pierced Salt, by J. Younge & Co.
Date 1785 Author.



Oval Octagonal Pierced Salt, by
M. Fenton & Co.
Date 1787. Davis, Manchester.



Pierced Salt, by R. Morton & Co.
Date 1788. Coopland, Sheffield.



Pierced and Engraved Salt, by I. Love & Co.
Date 1788. Franklin & Hare, Taunton.

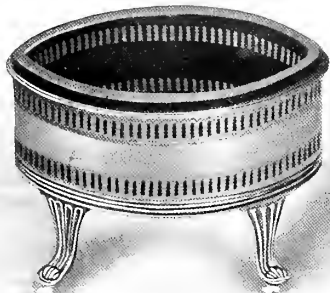

Pierced Pointed Oval Salt, by I. Love & Co.
Date 1789. Coopland, Sheffield



Pierced Pointed Oval Salt, by T. Fox & Co.
Date 1792. Elkington, London



Oval Shaped Top Pierced Salt, by
G. Ashforth & Co.
Date 1794. Author.



Hexagonal Shaped Top Salt, by
N. Smith & Co.
Date 1798. Withers, Leicester.



Oval Shaped Top Fluted Salt, by
I. Love & Co.
Date 1799. Coopland, Sheffield.



Oval Fluted Canoe Salt Cellar, by N. Smith & Co.
Date 1800. Mr. H. Hunt, Sheffield.

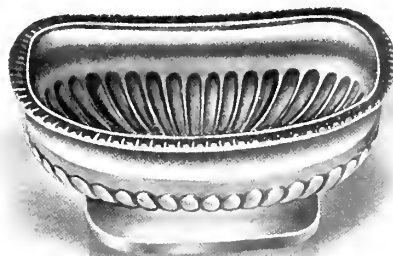

Oblong Fluted Salt, by J. Roberts & Co.
Date 1805. Hunt, Preston.



Oblong Gadroon and Shell Salt, by
M. Boulton, Birmingham.
Date 1808. Coopland, Sheffield.



Round Salt, mask feet, by N. Smith & Co.
Date 1803. Dunthorne, Liverpool.



Round Salt, with gadroon mount and ball feet,
by M. Boulton & Co. Author.
Date 1808.



Oblong Salt, with shell at corners, by J. Roberts & Co.
Date 1810. Author.



Fluted Mounted Salt, by J. & T. Settle.
Date 1818. Mrs. C. E. Bradbury.

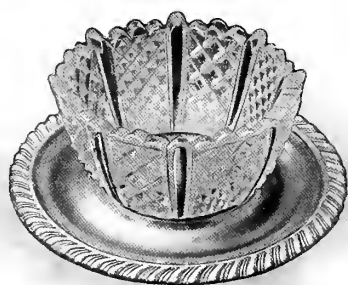

Round Gadroon Salt, with heavily cut glass, by
Watson & Bradbury. Lake & Son, Exeter.
Date 1809.

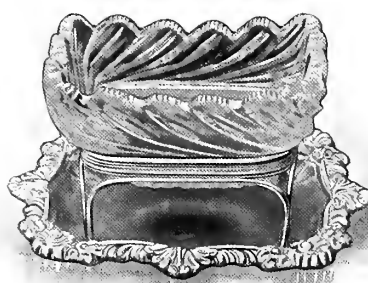

Oblong Fluted Border Salt, with wire supports and
heavily cut glass, by J. & T. Settle. Lake & Son, Exeter.
Date 1818.



Pierced Mustard Pot, on feet, by
M. Fenton & Co.
Date 1775. Author.



Vase Shaped, Pierced and Chased
Mustard Pot, by N. Smith & Co.
Date 1785. Author.



Round Pierced Mustard Pot, by
Tudor & Leader.
Date 1784. R. Jones & Sons, Liverpool

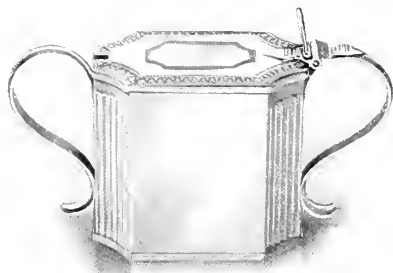

Double-handed Mustard Pot, for use in
a soy frame, by Watson & Bradbny.
Date 1795. Wilson & Sharp, Edinburgh



Oval Pierced and Chased Mustard
Pot, by T. Fox & Co.
Date 1789 J. H. Mogg, Bristol.



Oval Plain Mustard Pot, by
M. Fenton & Co.
Date 1792. Author.



Round Barrel Shaped Mustard Pot,
by T. & J. Creswick.
Date 1811. Author.



Round Fluted Mustard Pot, by
D. Holy, Parker & Co.
Date 1809. Coopland, Sheffield.



Round Plain, gadroon Mount Mustard
Pot, by Roberts, Cadman & Co.
Date 1816. Coopland, Sheffield.



Pierced Muffineer, 3 ³/₄ in. high, with blue glass lining, by J. Younge & Co.
Date 1785. Robinson & Co., Shrewsbury.



Pierced Muffineer, 4 ¹/₄ in. high, with blue glass lining, by T. Law & Co.
Date 1786. Author.



Plain Muffineer, 3 ³/₄ in. high, by George Eadon & Co.
Date 1814. Ford & Son, Newark.

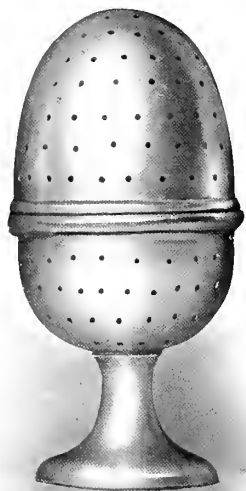

Tea Infuser as Muffineer, 3 ³/₄ in. high, from an egg frame, by Roberts, Cadman & Co.
Date 1817. Author.

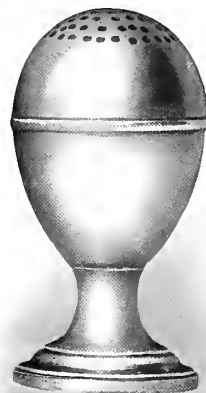

Small Plain Muffineer, 3 in. high, by George Eadon & Co.
Date 1814. Author.

SALVERS AND TRAYS.

Waiters, or salvers, were amongst the earliest articles to be manufactured by Joseph Hancock when he commenced the making of plated goods, and illustrated earlier in this work will be found a specimen of an Old Sheffield plated salver given by Boulsover to his daughter Mary on the occasion of her marriage in the year 1760 (see page 25). It would be interesting to know who was the maker of this article, but unfortunately it is impossible to ascertain that fact.

More care had to be taken with the manufacture of salvers than was necessary with the greater number of articles made in the olden days, on account of the hard wear they were subjected to by being in constant daily use. Earlier in this work the subject of making waiters and trays has been pretty exhaustively dealt with, so that it only now remains to give illustrations of some of the most popular styles. As regards their borders or mounts, the varied designs of waiters and trays during the first half of the 19th century is really bewildering, and shows a wealth of imaginative conception on the part of the Sheffield Plate manufacturers never approached by the leading London silversmiths.



7 in. Shell Border Salver (the metal for mounts and plate duplicated), by Tudor & Leader.
Date 1765.

Author.



14 in. Bead and Rosette Mount Salver, by Matthew Fenton & Co.
Date 1775.

Author.



20 in. Plain Salver, with shaped gadroon border,
by Tudor & Leader. Author.
Date 1775.



10 in. Plain Border, Chased Plate Salver, by
M. Fenton & Co. Author.
Date 1778.



16 in. Oval Plain Thread Mount Tray, by
George Eadon & Co. Author
Date 1805.

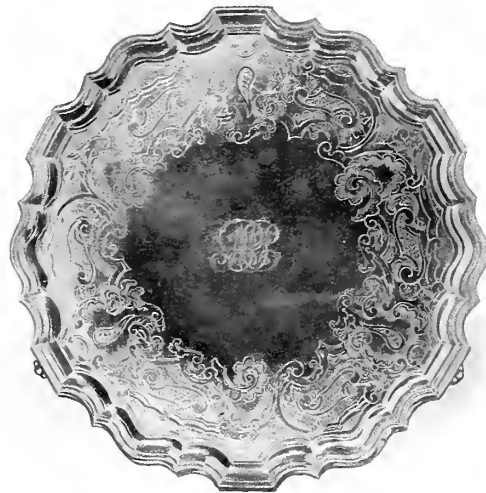

16 in. Chippendale Border Salver, with "Hogarthian"
chasing, by Watson & Bradbury. Author.
Date 1809.

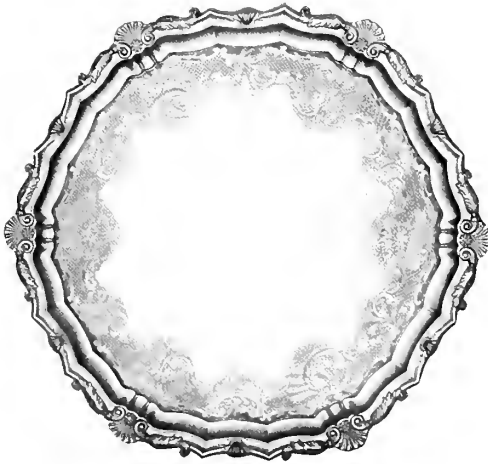

18 in. Shell Border Salver, with "Hogarthian"
chasing, by Tucker, Fenton & Co.
Date 1814. Mr. J. Thorp Haddock, Sheffield.



10 in. Shell Border Salver, chased plate, by
Watson & Bradbury.
Date 1815. Author.



14 in. Shell and Scroll Salver, chased plate, by
S. & C. Younge & Co.
Date 1815. Lake, Exeter.



10 in. Chippendale Salver, chased plate, by
Watson & Bradbury.
Date 1815. Author.



14 in. Chased Plate Salver, with mask heads in border,
by T. & J. Creswick.
Date 1816. Davis, Manchester.



9 in. Shell and Gadroon Border Salver, by
Gainsford & Nicholson.
Date 1812. Author.

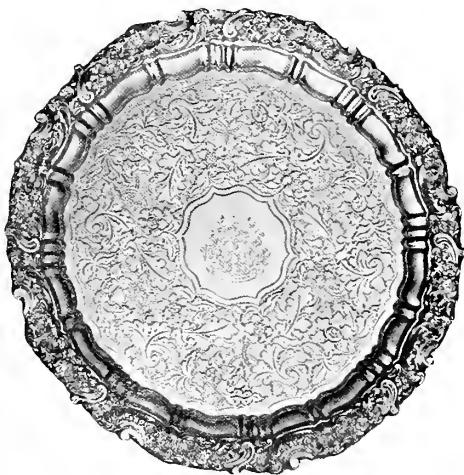

12 in. Chased Plate Salver, made in
Birmingham.
Date 1820. Vander & Hedges, London.



17½ in. Shell Border Chased Plate Tray, by T. & J. Creswick.
Date 1818. Miss Bradbury.



18 in. Oak Leaf Border Tray, tinned at the back, with soldered-in shield, on back initials.

A.S.

Date 1818.

Emanuel, Southampton.



18 in. Shaped Shell Border Tray, tinned at the back, with soldered-in shield

Date 1818. Emanuel,
Southampton.



24 in. Chased Plate Tray, with vine pattern border, by Matthew Boulton & Co., Birmingham.
Date 1823. Blackford, Lynton.

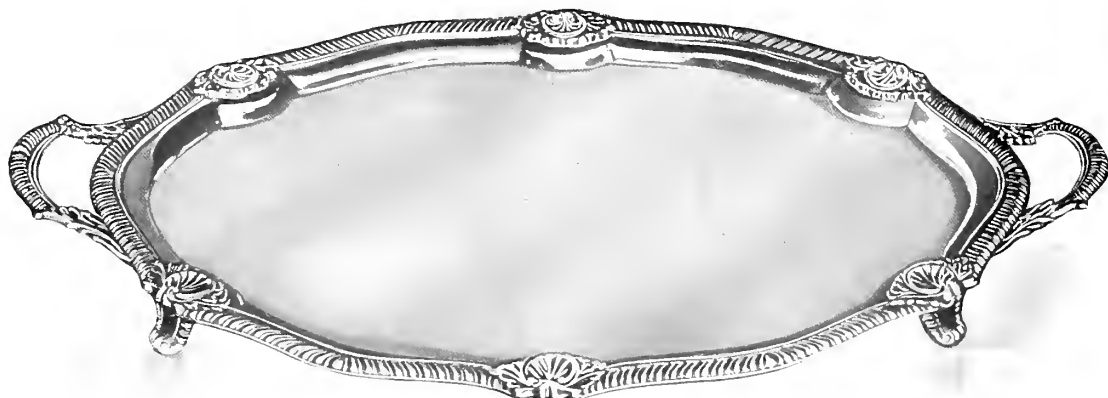

24 in. Oval Shell and Gadroon Border Tray, by N. Smith & Co.
Date 1808. Vander & Hedges, London.

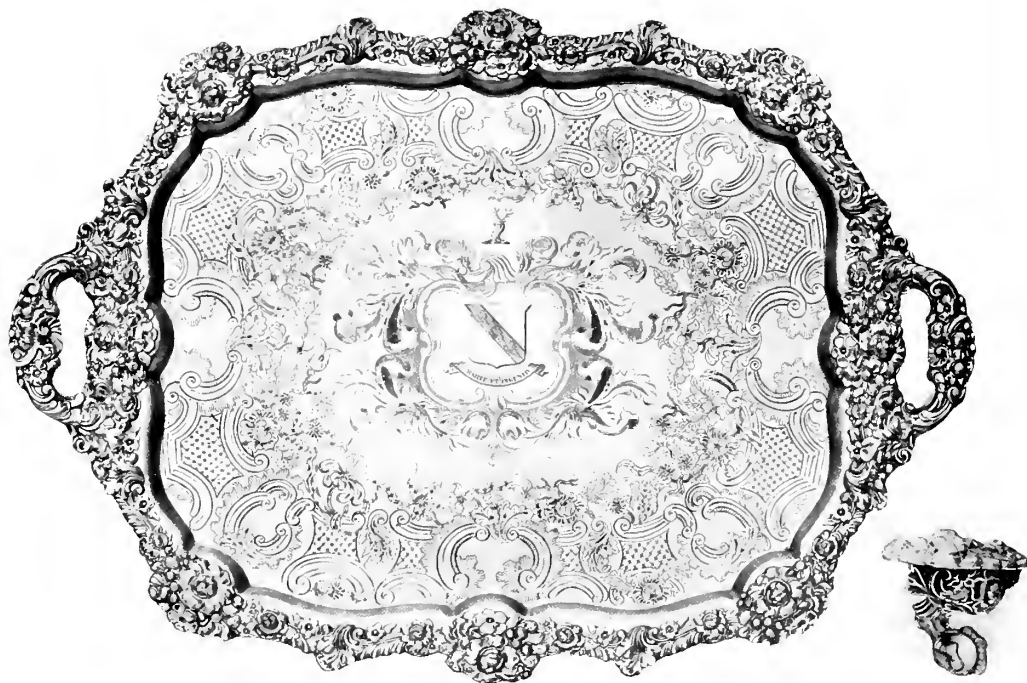

23½ in. Oblong-shaped Chased Plate Tray, with heavy mount intertwined with gadroon and flowers.
On this tray are two separate rubbed-in silver shields for engraving crests. An unusual example,
by Gainsford & Nicholson. (Inset, foot of tray.)
Date 1817. Chapple & Mantell, London.

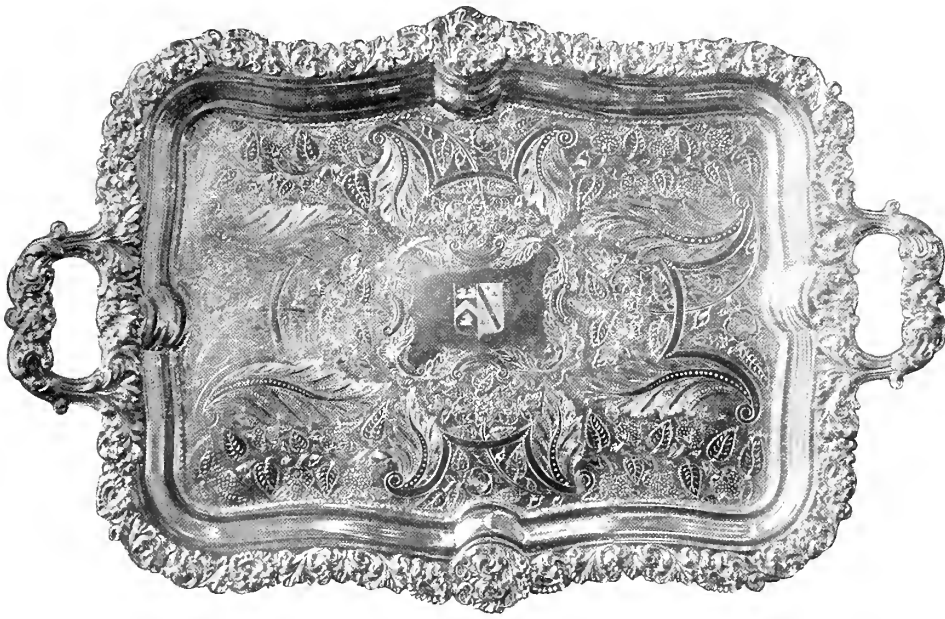

22 in. Heavily Mounted Tray, by Gainsford & Nicholson.

Date 1822.

Mr. Head, Stockton-on-Tees.

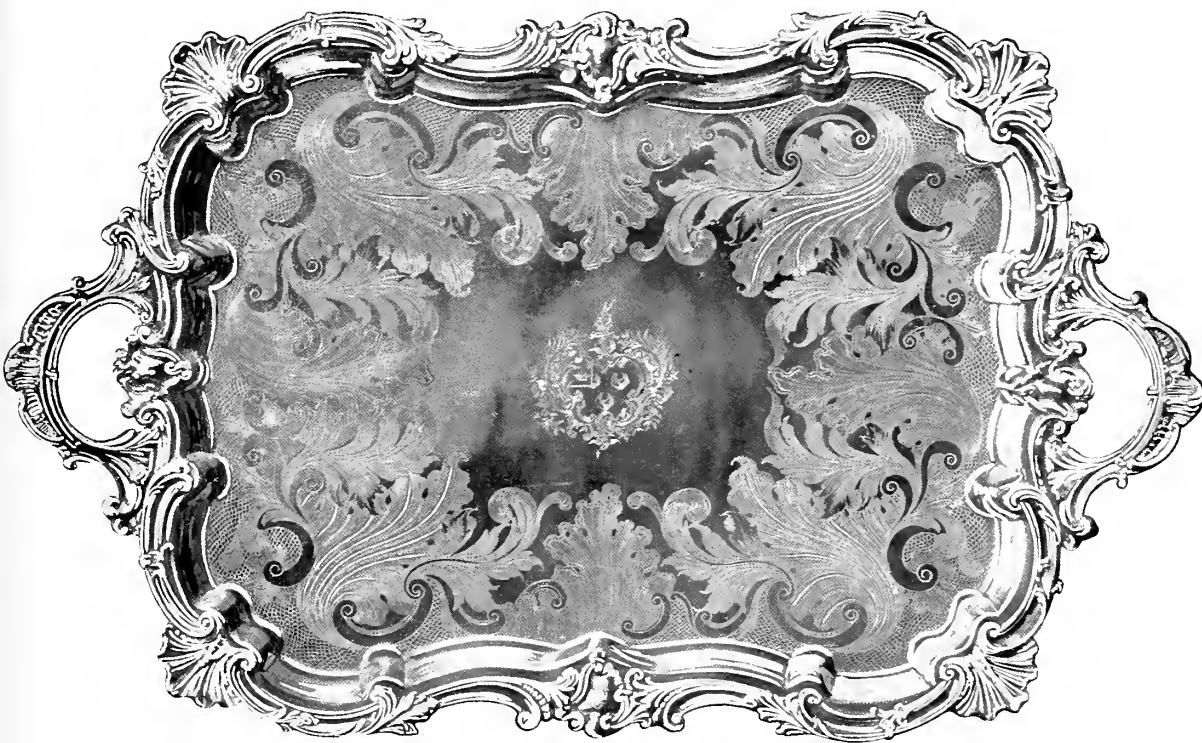

24 in. Chased Plate Tray, with shell and scroll mount, by Roberts, Smith & Co.

Date 1828.

Blackford, Lynton.



24 in. Heavily Mounted, Chased Plate Tray, by Watson, Pass & Co.
Elkington & Co., London.

Date 1821.

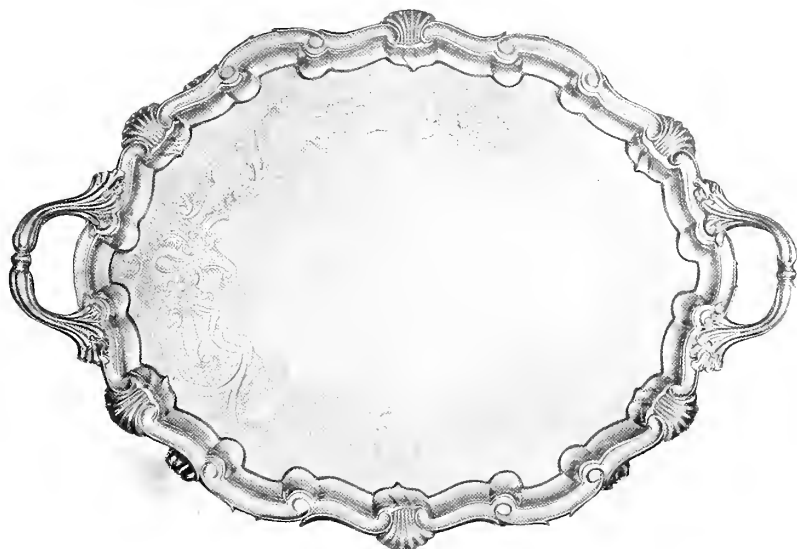

Oval 22 in. Chased Plate Shell Border Tray, by Kitchen, Walker & Curr.
Date 1833. J. Hall & Co., Manchester.

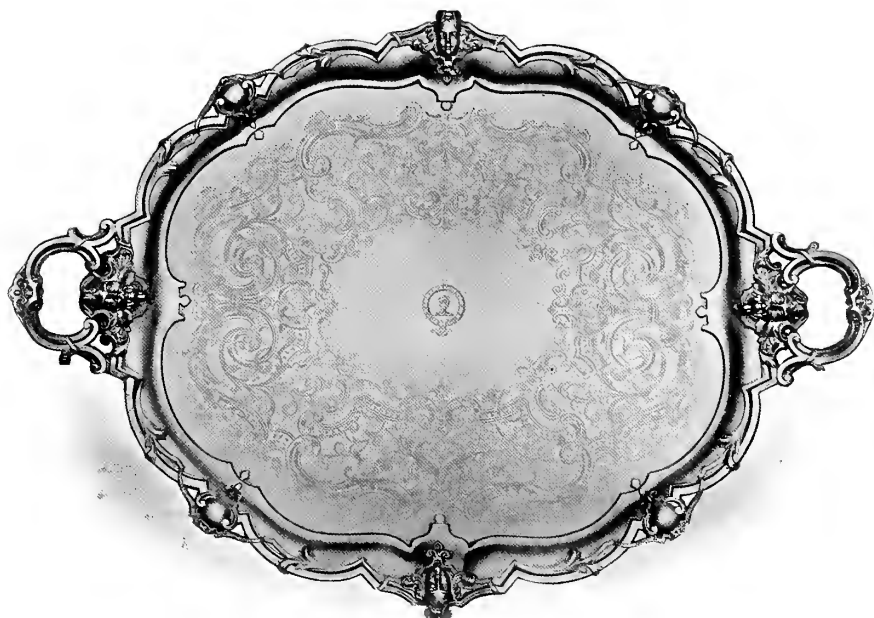

Oval 24 in. Chased Plate Mask Head Border Tray, by T. J. & N. Creswick.
Date 1828. Author.

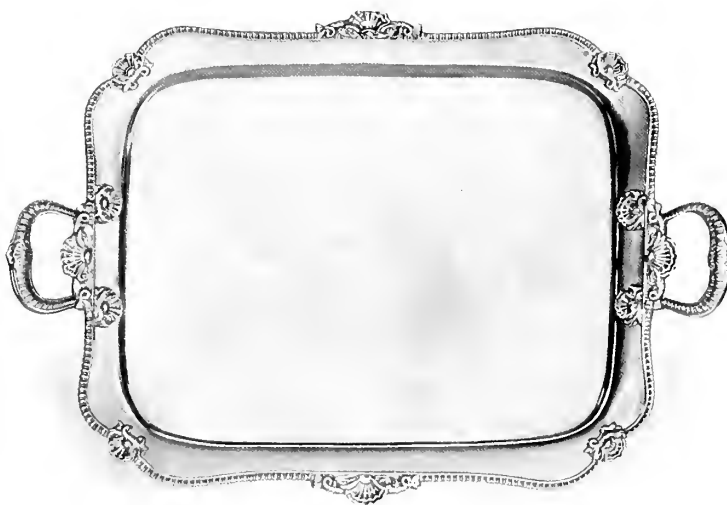

22 in. Oblong Shell and Dolphin Pattern Border Tray, by Gainsford & Nicholson.
Date 1810. Franklin & Hare, Taunton.

SNUFFER TRAYS.

The variety of patterns and styles of snuffer trays is truly amazing. They may be classed along with wine coasters as being the commonest and most sought-after products of the Old Sheffield manufacturers.

Originally always made as stands on which to place the snuffers, they have to-day come into use for a variety of purposes, such as sweetmeat trays, pen trays, trays for toilet articles, tobacco ash trays, etc., etc. Some connoisseurs have whole collections of these popular little articles of varied periods, styles and formation, a few of which are here illustrated.

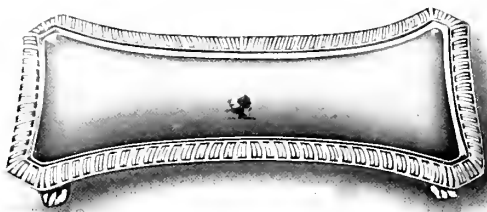

Gadroon Mount Snuffer Tray, with feet,
by Tudor & Leader. Author.
Date 1768.

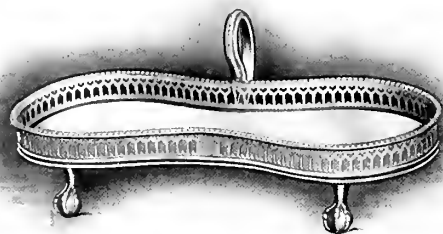

Pierced Upright Border Snuffer Tray, with handle
and feet, by R. Morton & Co.
Date 1775. Cambray, Oxford.



Oval Pierced Snuffer Tray, by N. Smith & Co.
Date 1785. Author.

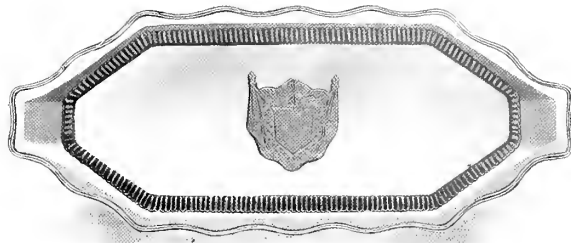

Oblong-shaped, Pierced Swage, Thread Mount Snuffer Tray,
with soldered-on silver shield, by Roberts, Cadman & Co.
Date 1785 Vander & Hedges, London.

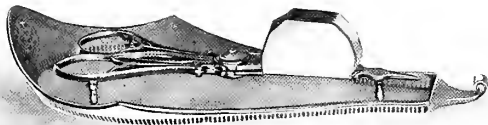

Oval Boat-shaped Pierced Snuffer and Tray, with scroll end
(a rare design), by N. Smith & Co. Author.
Date 1787.



Oblong Snuffer Tray, with mask head silver mounts, by
Morton & Co. Wilson & Sharp, Edinbro'.
Date 1788.

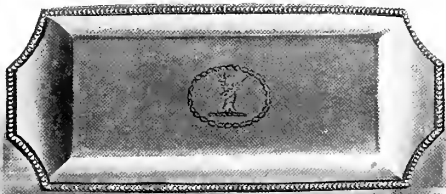

Oblong Silver Mounted Snuffer Tray, by T. Law & Co.
Date 1795. Heming & Co., London.

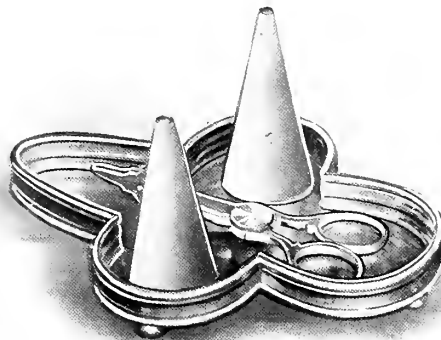

Shape-sided Plain Snuffer Tray, with extinguishers and
snuffers, by D. Holy, Wilkinson & Co. Author.
Date 1800.

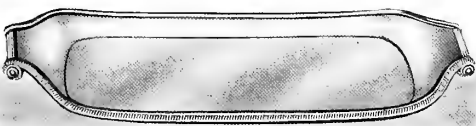

Scroll end Silver Mounted Snuffer Tray, by
Watson & Bradbury. Author.
Date 1804.

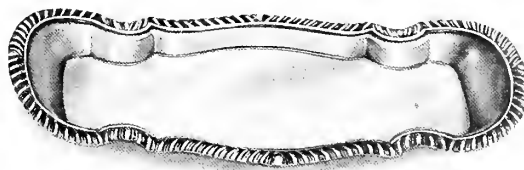

Shaped Gadroon Mount Snuffer Tray, with silver
mounts, by Roberts, Cadman & Co.
Date 1808. Mr. H. C. Casley, Ipswich

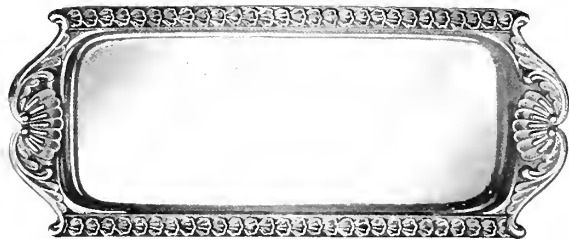

Oblong Snuffer Tray, with silver shell end mounts,
by Gainsford & Nicholson.
Date 1815. George, Bristol.



Oblong Snuffer Tray, with silver mounts—Rose, Shamrock
and Thistle—chased plate, by Gainsford & Nicholson.
Date 1815. Author.



Large Snuffer and Tray, with heavy silver florid mounts, by J. & T. Settle.
Date 1818. Author.

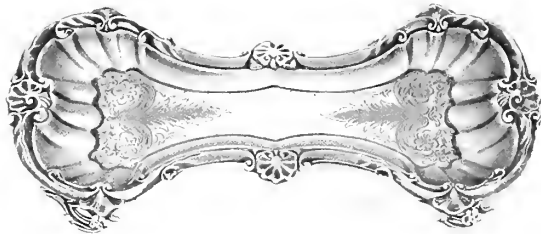

Shaped Snuffer Tray, with silver mounts, on pierced
feet, chased plate, by I. & I. Waterhouse & Co.
Date 1833. Author



Snuffer Tray, with silver mounts, a registered design,
by "Mapplebeck & Lowe, Jan. 27, 1840," No. 227.
Author.

SOUP AND SAUCE TUREENS, SAUCE BOATS.

The earliest tureens for soup in Old Sheffield Plate are of a rather light description and not very large, their holding capacity rarely exceeding three quarts. Between the years 1790 and 1800 oval tureens, described in the pattern books as "oval canoes," were the most popular; but such are very scarce to-day. This is somewhat of a surprise, as innumerable varieties of these shapes are described in pattern lists of the latter part of the 18th century. The large floreated examples of the earlier 19th century soup tureens are a triumph of skill, both in design and execution, and to-day command high prices.

The sauce tureens made in Old Sheffield Plate outnumbered the soup tureens by almost 10 to 1 in their varieties of pattern. They were always sold in pairs, and to-day bring high prices when brought under the hammer. Sketchley mentions tureens in his list of the year 1774, but does not state whether for soup or for sauce. However, the sauce tureens followed closely on the lines of the soup tureens and vice versa. In the old pattern books both are classed under one heading, viz., "tureens." The manufacture of sauce or butter boats, with lips, began with the introduction of double side plating, probably between the years 1763-1770.



1-pint Oval Bead Mount and applied Festoon Ornament Sauce Tureen, with stand,
by J. Hoyland & Co.

Date 1774.

Wilson & Sharp, Edinbro'.



2½ quart Oblong Soup Tureen, by
Watson & Bradbury.
Date 1812. Dr. G. Porter, Surbiton.



4-quart Oval Shaped Soup Tureen, with
rococo ornament, by D. & G. Holy & Co.
Date 1826. Elkington & Co., London.

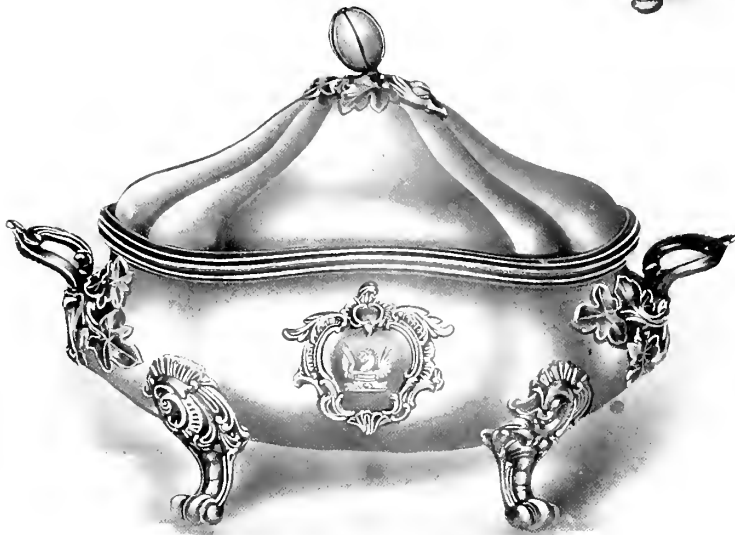

4-quart Oval Shaped Soup Tureen,
by S. & C. Younge & Co.
Date 1828. Author.

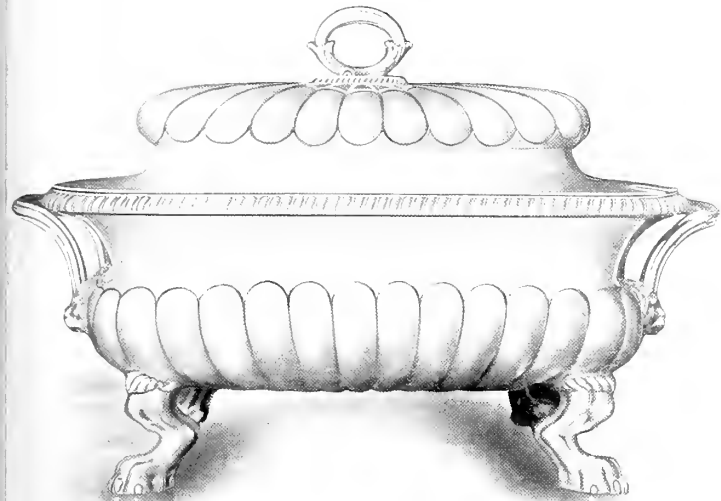

4-quart Oblong Gadroon Mount Fluted Body
Soup Tureen, with claw legs, and lion
supports for handles, by Watson & Bradbury.
Date 1801. Author.

4-quart Oblong Gadroon Mount Soup Tureen,
with entrée dish top, by J. Watson.
Date 1810. Lambert, London.



5-quart Oval Gadroon and Shell Soup Tureen,
with lion head supports, by M. Boulton & Co.,
Birmingham.
Date 1818. Winston, Cardiff.



1-pint Gadroon and Shell Mount Sauce Tureen, by
N. Smith & Co.
Date 1813. Lake & Son, Exeter.



1-pint Gadroon Mount Sauce Tureen, with heavy rococo
ornament, by D. & G. Holy & Co.
Date 1826. Lambert, London.



1-pint Gadroon and Shell Mount Sauce Tureen, by
Watson & Bradbury.
Date 1818. Vander & Hedges, London.



1½-pint Reid's Mount Sauce Tureen, shaped cover and body,
by J. Dixon & Son.
Date 1835. Coolpland, Sheffield.



1-pint Oblong Sauce Tureen, with fluted cover, by
Tucker, Fenton & Co.
Date 1808. D. & M. Davis, Birmingham.



1-pint Oblong Gadroon Mount Sauce Tureen, by
T. & J. Creswick.
Date 1811. Author.



1-pint Oval Sauce Tureen, with scroll end and ring handles, by Danl. Holy, Wilkinson & Co.
Date 1798. Elkington & Co., London.



1-pint Round Sauce Tureen, on foot, with ring handles and Lion head supports, by Roberts, Cadman & Co.
Date 1803. M. & S. Lyon, London.



1½-pint Oblong Sauce Tureen, on stand, with ring handles and Lion head supports, by Watson & Bradbury.
Date 1808. Butt & Co., Chester.



1-pint Sauce Boat, with plain shaped mount and sunk flutes on body,
by Roberts, Smith & Co
Elkington & Co., London.
Date 1828.



1/2-pint Oval Fluted Body Sauce Boat, design taken from an English
China Sauce Boat.
Dunthorne, Liverpool.
Date 1792.

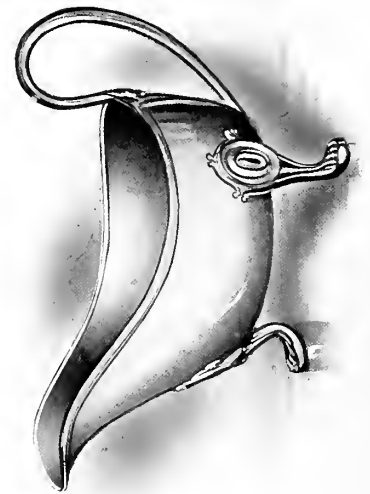

3/4-pint Sauce Boat, by Ashforth, Ellis & Co.
Date 1803.

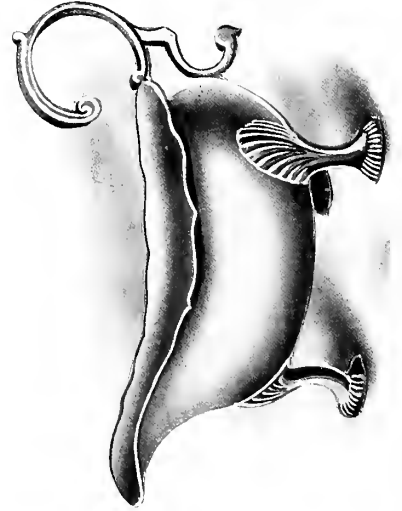

1/2-pint Sauce Boat, by T. Law & Co.
Date 1780.
Author.

SPOONS AND FORKS, ETC.

Perhaps the only class of goods to which the Old Sheffield Plate Makers may be said to have turned their attention without entire success was table ware in the form of spoons and forks, soup ladles, gravy spoons, etc. Repeated attempts were made throughout the progress of the industry to oust the more popular solid silver productions with but little success.

Innumerable flimsy little tea spoons and sugar tongs are still to be found, made between the years 1770-1790, beaten out from drawn wire with flat chasing on the shanks. Others were made from twisted wire, but surviving specimens of these tea spoons and tongs retain little or no silver plate. Some of the tongs are marked inside the bows "BEST PLATE" others "PLATED" and on shanks of spoons we find **SILVER-SOLDER**. 

Early productions of plated spoons, forks, etc., are shown on next page. The two Fiddle pattern tablespoons illustrated have shanks beaten out of thick metal and then bevelled on the edges, whilst the bowls—soldered on separately—are struck from dies. The dovetailing, where the shank has been soldered to the bowl, is discernible.

An attempt at making plated forks seems to have been made very early in the history of the industry, of which illustrations are also given. These forks were stamped out of plated metal longitudinally in two complete halves, and subsequently soldered together after having been filled up solid with a mixture of tin and lead (mentioned in the notes by Dixon, page 30).

The difficulties the Sheffield plate makers had to encounter in the production of plated spoons and forks can easily be realised by the illustrations given on page 337 of the modern method of manufacture. These difficulties were consequent on the necessity for cutting out of very thick metal (of varying gauges) the blanks from which the spoons and forks were to be made. In the olden days the cutting out of the blanks, which must necessarily have been undertaken after they had been plated, would expose far too big a raw surface for articles which had to come in contact with food, and the forging system (the metal having previously been plated) would also be quite an impossible mode of procedure. In the cases of solid silver spoons and forks this latter method of production was universally resorted to.

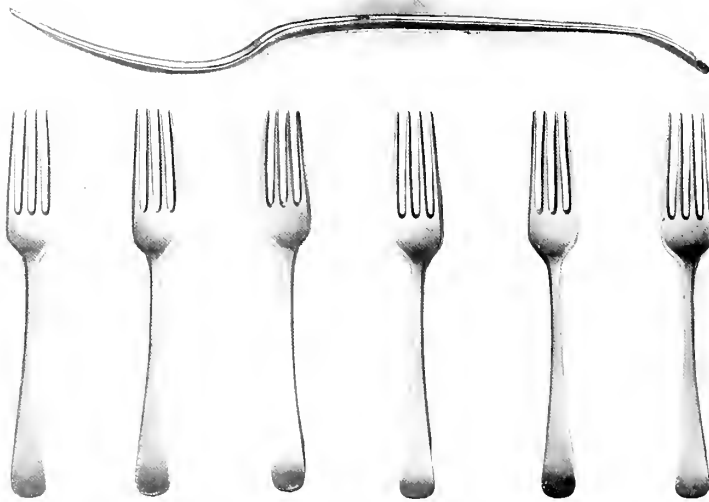

Earliest method of making fused-plated Forks. Two sections stamped longitudinally, filled with tin and lead, then soldered together (the seams being slightly visible), silver points are attached by soldering to the prongs of forks.
Date 1760. Mr. W. P. Belk, Sheffield.

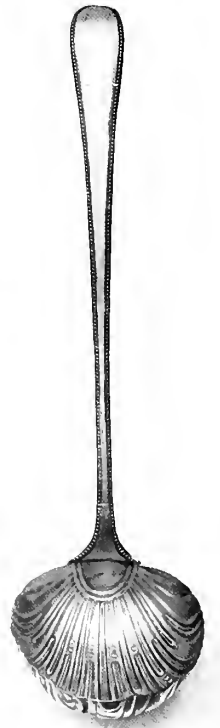

Fused-plate Soup Ladle, shank soldered on separately, stamped in two halves and filled with tin and lead, bowl struck from a die and soldered to shank, by N. Smith & Co.
Date 1784. Comber, Woking.

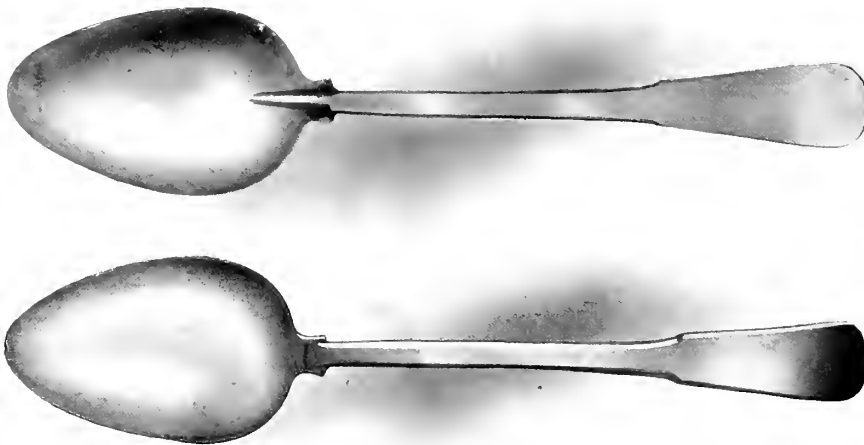

Later method of making Spoons. The shanks cut out of thick plated metal and bevelled to a thin edge by the aid of a hammer, the bowls struck from dies and soldered on separately. Illustration shows obverse and reverse of spoons, by T. Law & Co.
Date 1810. Author.



Sugar Tongs, made from plated drawn wire and chased by hand, by T. Law & Co.
Date 1777. Author.



Tea Spoons, shanks made from plated drawn wire, and chased by hand, the bowls struck from a die and soldered on separately, by T. Law & Co.
Date 1777. Author.



Caddy Spoon, struck in a die from fused-plated sheet metal, by T. Law & Co.
Date 1785. Author.



STRIP

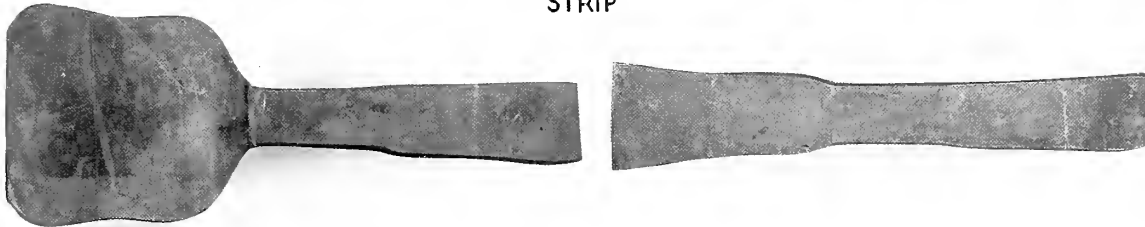

CROSS ROLLED BLANK

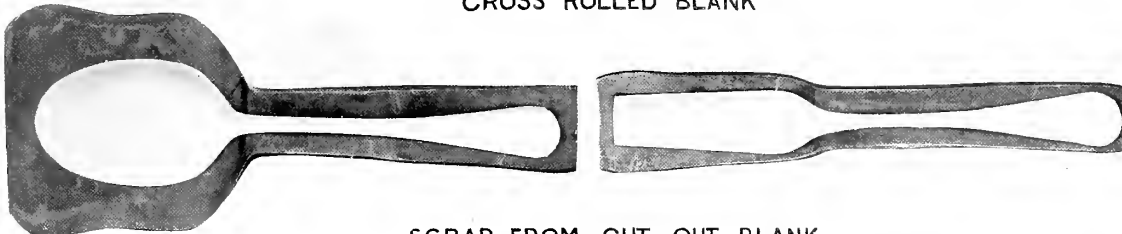

SCRAP FROM CUT OUT BLANK

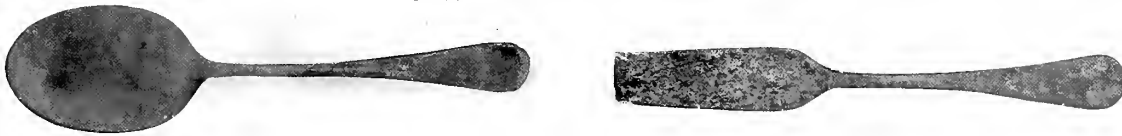

CUT OUT BLANK

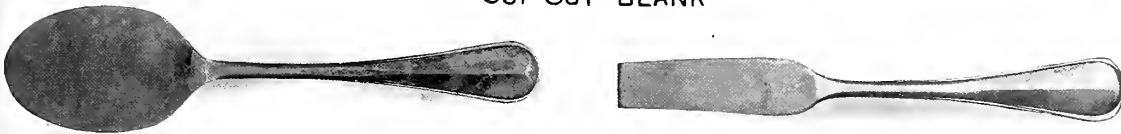

STAMPED BLANK



BOWLED & PRONGED



FILED



BUFFED



PLATED

Showing the modern method of manufacturing Spoons and Forks chiefly by the aid of machinery.

It was not until between the years 1840-1850 that the Sheffield manufacturers began to produce spoons and forks, both in silver and plate, in any great quantities. The introduction of the process of electro-plating completely revolutionized their manufacture. The difficulties hitherto experienced vanished altogether when the articles could be plated with silver after they had been cut out, stamped, filed and buffed. And as the Sheffield manufacturers acquired the trade of making plated spoons and forks they gradually also absorbed the larger proportion of their production in silver, these formerly having been made almost entirely by the London silversmiths.

To W. Hutton & Sons, of Sheffield, credit is due for being the first firm to manufacture spoons and forks from the newly-invented metal called Argentine, in the year 1833. These were at first close plated, whilst the points of the forks were composed of solid silver.

STAFFORDSHIRE WARE, MOUNTED BY THE OLD SHEFFIELD PLATERS.

A special feature of T. Law & Co.'s business appears to have been the mounting of fine stone and jasper ware, vases, mugs, jugs for both milk and cream, hot water jugs, and a general variety of articles.* They are to-day by no means common, however, outside the precincts of museums and private collections; but such as are to be met with—unbroken—are always very much prized by collectors. The various subjects depicted in high relief round the bodies of these specimens are so numerous as to form quite an education in classical history, and a large proportion of the designs are attributed to Flaxman. Like the Old Sheffield platers, the potters took copy from each other's designs, and we find similar articles with silver and Old Sheffield mounts thereon made by Wedgwood, Adams,† Turner, and others. Flaxman, however, would be the designer from whom they took their chief inspiration. He was born in the year 1755 and died in 1826, being at the height of his fame during the most prosperous period of both the Staffordshire potters and Old Sheffield Plate makers. It is interesting to state that Mr. B. H. Hoole, who owns the very beautiful stoneware vase and cover illustrated on page 340 is a great-great-grandson of the original Thomas Law, who was born in the year 1717.

* Horn beakers, hollow ivory tusks, and cocoanuts split in halves, mounted both with plated and silver rims for the purpose of drinking vessels are still very numerous. The majority—made between the years 1770-1800—were manufactured by Law, Fenton, Tudor, and Love.

† The author begs to acknowledge great indebtedness to Mr. Percy W. L. Adams, himself a descendent of the old Adams' family of potters, for much assistance in connection with this subject.



3-pint Adams' Mug, "The triumph of Bacchus,"
mounted by T. Law & Co.
Date 1795. Basker, Grantham.



2 1/2-pint Adams' Jug, "The triumph of Bacchus,"
mounted by T. Law & Co.
Date 1795. T. Worthington,
Burton-on-Trent.



3-pint Stoneware Mounted Jug, "Hunting Scene."
Date 1805. Author.



Blue and White Jasper Cream Jug, mounted by T. Law & Co.
Date 1806. Author.



Vase and Cover, 9 in. high, of fine stone Turner ware, "Sacrifice to Diana," reverse Psyche and Doves, mounted by T. Law & Co.
Mr. B. H. Hoole, Sheffield.
Date 1798.



2-quart Blue and White Jasper Jug, Adams' ware, "Sacrifice to the Apollo Belvedere" reverse "Sacrifice to Diana," mounted by T. Law & Co.
Date 1802.
Author.

SUGAR BASINS AND CREAM EWERS.

Until early in the 19th century sugar basins in Old Sheffield Plate were not made in conjunction with the cream jugs and the pots as "services," but we find them illustrated together with the cream jugs in the old platers' pattern books issued about the year 1798 (see page 413), and described as "sugar bason and cream bason." As a matter of fact and apart from the difficulty always experienced in making three pieces of a tea service look homologous, the sugar basins were in earlier times more usually requisitioned for the dinner table, as were also the cream jugs. The former were always at hand when toddy was served at night and when the many ingredients associated with the concoction of punch were set out.

Powdered or sifted sugar has apparently been in daily use a great number of years, for we find sugar sifters described in detail in the earliest Sheffield plate catalogues; whilst sugar dredgers in silver, bearing Queen Anne and earlier period hall marks are still quite plentiful.

Old Sheffield plated castors for sugar are very scarce in large sizes, and only one is illustrated in this volume.



Sugar Basin, Pierced and Chased in high relief, 4 in. high, with blue glass lining, by R. Morton & Co.

Date 1775.

Author.



Fluted, Pierced, and lightly Chased Sugar Basin, 5½ in. high, with side handles and blue glass lining, by T. Fox & Co.

Date 1784.

Lake & Son, Exeter.



Flat Chased and Pierced Sugar Basin, 4½ in. high, with glass lining, by J. Hoyland & Co.

Date 1779. Elkington & Co., London.



Pierced and Chased Sugar Basin,
4½ in. high, with blue glass lining,
by J. Younge & Co.

Date 1780. Robinson & Co.,
Shrewsbury.



Pierced and Chased Sugar Basin,
5 in. high, with blue glass lining,
by M. Fenton & Co.

Date 1780. Author.



Wire Work Sugar Basin, 7½ in. high, with clear
cut glass lining, and engraved silver band, by
S. Kirkby & Co.

Date 1799.

Author.



Double Bar Pierced Sugar Basin,
5½ in. high, with blue glass lining,
by Tudor & Leader.

Date 1785. Davis, Manchester.



Wire Work Sugar Basin, 5⅜ in.
high, with clear glass lining
and pierced border, by
R. Morton & Co.

Date 1800.

Author.



Oval Helmet Pattern Sugar Basin, gilt inside, $\frac{3}{4}$ -pint size, with silver engraved band soldered on, by M. Fenton & Co.
Date 1792. Franklin & Hare, Taunton.



Sugar Castor, $7\frac{1}{2}$ in. high, by T. Fox & Co.
Date 1789. Vander & Hedges, London.



Octagonal Thread Mount Sugar Basin and Cream Pail, with silver engraved band soldered-on and swing handles, by D. Holy, Wilkinson & Co.
Date 1789. Vincent, Yeovil.



Tall Chased $\frac{1}{2}$ -pint Milk Jug, by
T. Law & Co.
Date 1778. Franklin & Hare, Taunton.



Oblong Engraved Band and Fluted $\frac{1}{2}$ -pint Cream Jug,
by Roberts, Cadman & Co.
Date 1798. Coopland, Sheffield.

SUPPER SERVICES AND TEA MACHINES.*

Specimens of both these "combined" productions are very scarce; they were quite the largest and most expensive of all the articles made in Old Sheffield Plate. A complete supper service, including salt cellars, entrée dishes and soup tureen on revolving stand, such as is shown on page 345, would cost originally between £40 and £50. The tea machine illustrated on page 416 and reproduced from an old catalogue, cost £30.

There may be examples of both these descriptions locked away in the strong rooms at banks, in the old plate chests at country mansions, or elsewhere; but so far as the average collector is concerned the evidence of their existence is of the same nature as that on which rests his knowledge of some pre-historic animal. As is the case with specimens of palæolithic fauna, parts only are to be found of what was originally a complete entity.

As regards the supper stands they would presumably be in use for theatre goers, chiefly in London, where a century ago fashionable restaurants were not so numerous as to-day, and people were more largely entertained in private houses. By means of the large hot water compartments into which the entrée dishes fitted, food could be kept hot for a considerable time

* For illustration of Tea Machine see page 367.

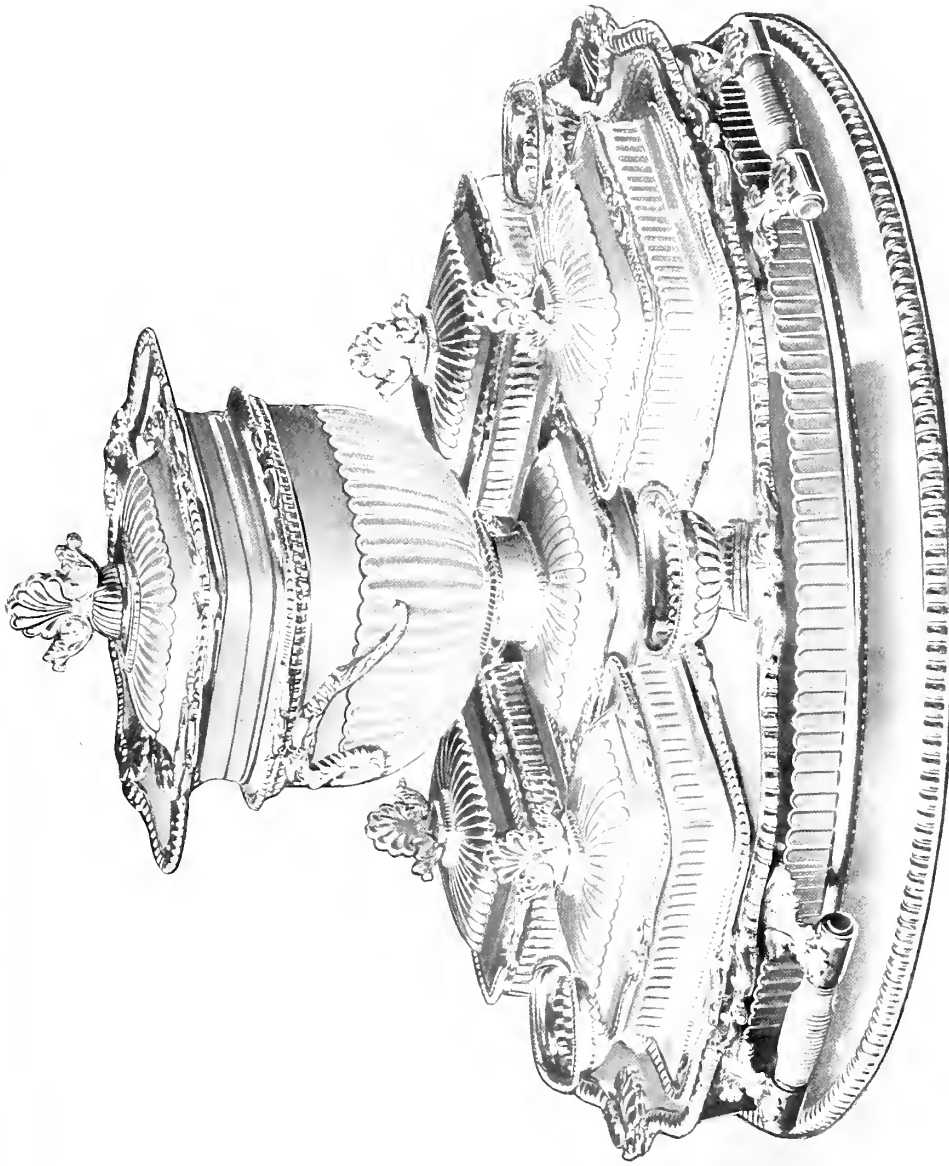

Supper Service complete, on revolving stand with hot water compartment, consisting of round fluted stand with three ivory handles and straight gadroon mounts, four salt cellars, four full sized fluted entrée dishes and covers, and one 6-pint fluted soup tureen with cover and handles, all detachable, by Nathaniel Smith & Co. Vander & Hedges, London.

Date 1866.

pending the return home of the host and his guests. The one "service" given in the list of articles referred to on page 197, is described in the pattern book as follows: "20" oblong tray with silver gadroon mount, handles, and ball feet, to which is fixed two large decanters and 12 small glasses."

TANKARDS, BEAKERS, CUPS AND BOWLS.

Tankards, with and without lids, cups, beakers and drinking vessels of all kinds are numbered amongst the most extensive products of Old Sheffield plated ware. Many manufacturers turned their attention to specializing in this class of articles, whilst others made nothing else. Thos. Law, Nathaniel Smith, John Love and Josephus Smith all made great quantities of cups and tankards, and specimens are to be met with almost daily by collectors of old plated goods. An illustrated page is reproduced below from one of the old Sheffield catalogues, where mention is made of the name "Winchester Measure."*



Reproduction of page from an old Sheffield Catalogue, published between the years 1780—1790.

* The following is an extract from the Sheffield register of July 21st, 1791.—"Spring Gardens, near Sheffield. Mr. Rollinson presents his respectful compliments to the publicans of Sheffield and the neighbourhood, and wishes to inform those who have not yet, in compliance with a recent regulation that no ale or beer shall be sold in any other but lawful Winchester Measures, legally stamped, had their silver or plated measures which are too small, exchanged for such as of legal size, that he repairs and enlarges old silver and plated quarts, pints and half-pints, in the neatest, completest, most expeditious, and cheapest manner. He also manufactures and sells new measures."



1-quart Tankard, with cover, by Thomas Law.
Date 1768. Author.



1-quart Tankard, by I. Love & Co.
Date 1783. Leighton, Lancaster.

There seems little doubt that the name was derived from the ancient city of Winchester. In Saxon times, when it was the seat of government, the standard measure was kept there, and the Winchester bushel was used in England from the time of Henry VII. to 1825, when the Imperial bushel of somewhat larger capacity was made the legal measure. It is stated that the "Winchester Pint" equals a quart, and no doubt it, too, would disappear in 1826, when a statute making weights and measures uniform came into operation. Sometimes these tankards are stamped with the initials I.M., which would mean Imperial Measure; others are marked with the royal crown and initials GRIV 1824 and in the case of tankards attested WR and in the case of tankards in Sheffield, they also bear the borough arms, the "cross arrows" (sometimes mistaken for the mark registered by T. & J. Creswick, in 1811). All tankards when so marked are for use in Inns, Hotels, or public places. The slits sometimes to be found underneath the lower portions of the hollow handles of tankards, both in silver and plate, it has been said, were made for the purpose of using the handle as a whistle (for more drink to be served). By reversing the tankard when empty and blowing across this aperture a kind of noise can certainly be produced from these hollow handles. But an opening of some sort in the handles was necessary to ensure that no accident occurred in the process of soldering them on to the bodies of the tankards.

Large bowls for punch, and two-handled large loving cups, capable of holding three quarts or more, are exceedingly scarce in Old Sheffield Plate.



Cup and Cover, 21 in. high \times 17 $\frac{1}{2}$ in., capacity 6 quarts, presented to Earl Fitzwilliam by the artizans of Sheffield and neighbourhood on his resigning the Lord Lieutenancy of the West Riding of Yorkshire, after holding office for 20 years, called the "Penny Cup" (subscriptions being limited to one penny per head).
by Watson, Pass & Co.

Date 1820.

Earl Fitzwilliam, Wentworth.



1 1/2-pint Two Handled Cup, fluted and chased, by T. Law & Co.
Date 1787. Greenwood, York.



Two Handled Plain Quart Cup, by N. Smith & Co.
Date 1790. Author.



1-pint Two Handled Chased "Queen Anne" Porringer, by
M. Fenton & Co. Author.
Date 1765.



1 1/2-pint Goblet, with silver mounts, by
Gainsford & Nicholson.
Date 1820. Davis, Manchester.



A Group of 1-pint Tankards, with silver mounts, formerly found in old inns and taverns, made between the years 1790 and 1820. The two-handled ones are the earlier; some of these have probably been in constant use for over a century. They bear the local test marks of the Borough of Sheffield, the cross arrows (somewhat resembling the registered mark of T. & J. Creswick).

Mr. G. H. Cottam, Sheffield.



Two-handled Fluted Loving Cup, with straight gadroon mount and rustic handles, holding one gallon,
by Samuel Kirkby & Co. Elkington & Co., London.
Date 1800.



Bowl in the form of a 16th Century Mazer, by
T. Law & Co. Heming, London.
Date 1795.



A Nest of six small Beakers, highest 2¼ in.,
by Watson & Bradbury. Lowe & Sons, Chester.
Date 1795.

TEA CADDIES AND CANISTERS.

We find that in the earlier lists of goods that were made by the Old platers, the patterns of the tea canisters or caddies followed very closely the outlines of the teapot bodies, and that a division was made down the centre of these bodies to keep the two kinds of tea, i.e., the black and the green, separate. The bodies of the two larger patterns illustrated on page 353 much resemble those of teapots, and these specimens could be used either for tobacco, biscuits, or tea, as desired. One interesting tea canister illustrated below is what is termed a masterpiece. Every apprentice on completing his indentures had to give practical proof of his competence by the manufacture, without assistance, of some article associated with the trade into which he had been initiated.



Octagonal Tea Canister, with two divisions, silver engraved borders and silver threaded edges, $4\frac{1}{2}$ in. high, $5\frac{1}{2}$ in. long, capacity $\frac{3}{4}$ lb., made by T. Bradbury, Junr., as a masterpiece on completing his apprenticeship in the year 1807. Author.

Tea caddies are generally found with locks and keys. Sometimes they are enclosed in a case fitted with a lock, as owing to the high price of tea in former times it was very carefully preserved by the housekeeper.

As with the majority of articles made in Old Sheffield Plate, there was no hard and fast rule for their size. Caddies were fashioned with more regard to design than holding capacity. With antique teapots also utility was frequently sacrificed to appearance, especially as regards the spouts. Who has not sympathised with the lady of the house when, owing to length and narrowness of spout, any attempt to pour more quickly by tilting the teapot has resulted in disaster to tray or tablecloth (see illustrations on page 355.)



Oval Plain Tea Caddy, or Canister, holding $\frac{3}{4}$ -lb. of tea, by D. Holy, Wilkinson & Co.
Date 1792. Blackford, Lynton.



Flat Chased Tea Caddy, holding $\frac{1}{2}$ -lb. of Tea, with lock and key, by J. Younge & Co.
Date 1779. Author.



Blunt Oval Plain Tea Caddy, with lock and key, holding $\frac{1}{4}$ -lb. of Tea, by Ashforth, Ellis & Co.
Date 1789. Author.



Small Tea Canister, with pull-off top, holding $\frac{1}{4}$ -lb. of tea, hand chased (one of a pair), by J. & T. Settle.
Date 1820. Simmonds, Monmouth.

TEAPOTS.

Teapots of English make are in existence from the time of Charles II. An oval fluted Georgian design, to-day commonly called "Queen Anne," was put on the market with a misleading name some 25 years ago. Those made during the Queen Anne period were generally cottage loaf or octagonal in shape.* A family group, painted by Hogarth, in the year 1720 (the property of Crichton Bros.), portrays a tea-party. On the table are displayed, in a typical octagonal design of the period, teapot, kettle, caddy, covered jug and sugar basin, also a slop basin.

* An advertisement in the "Dublin Gazette" of May 29th, 1711, reads:—"Captain George Roane, at the pewterers' and braziers' shop, Charles Street, has lately been in London and brought back . . . of very fine silvered ware. Bohee "teapots," stands and lamps, etc., etc., all said goods made by best artists in London."

Teapots are amongst the most common of articles to be found to-day in Old Sheffield Plate, but very scarce indeed are the complete services; those early ones that are in existence do not date back much before the year 1810. Teapots made prior to the year 1770 are very rarely met with in plate.

The different shapes of the teapot bodies are scarcely less multifarious than the variations of the styles of their mountings. The vagaries of the spouts, which commence with the perfectly straight ones found on the earliest made teapots in the years 1768 (see illustration page 88), and finish about the year 1850 with a tendency to revert to the earliest types, are an interesting study on which alone a chapter could be written. The forms of the handles, designs of the knobs, pods for the feet, difference in hinges, and variations of both chasing and engraving are of sufficient interest from a connoisseur's point of view to form the subject of a complete volume themselves. All-metal handles are not often found on teapots made singly, whereas they usually occur on the coffee pots and teapots forming part of complete services. The substances of which handles are most generally composed are stained wood, ebony, compressed horn, and—very rarely—ivory.

The same remarks hold good with regard to the teapot knobs, insignificant little adjuncts which yet at times give more character than anything else to the article they adorn. Of all forms of knobs, the green stained ivory pineapples* are undoubtedly the most pleasing and make the best finish. In the earlier days these knobs are most usually to

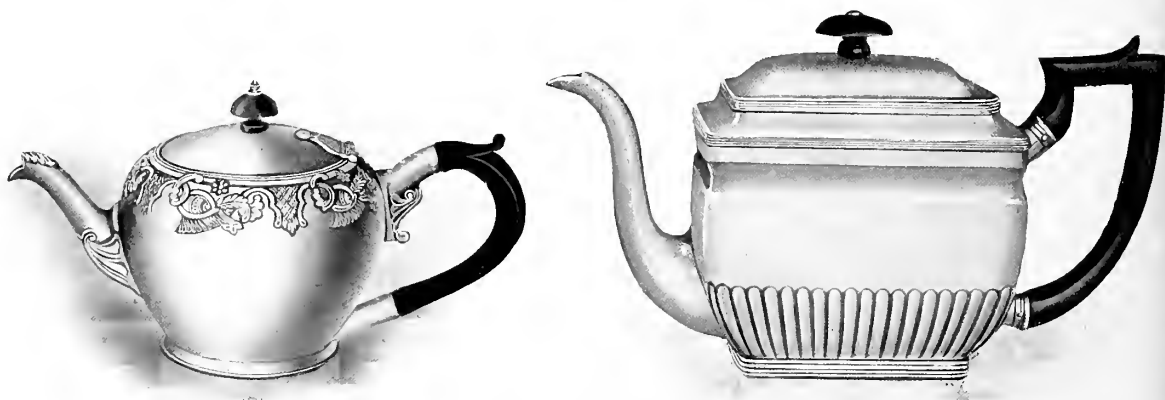

1½-gill Bullet Shaped Teapot, design taken from a
Geo. II. silver pattern, by Tudor & Leader.
Date 1785. Author.

4-gill Oblong Teapot, with straight flutes and thread
mounts, by Roberts, Cadman & Co.
Date 1800. D. & M. Davis, Birmingham.

* It has been stated that in olden times the pineapple knob was an emblem of hospitality.

be found on the lighter descriptions of teapots—such as those with engraved bands, etc. As mentioned before, separate stands for teapots went gradually out of use, after it became customary with the manufacturers to solder on small balls to the bases of the teapots to act as non-conductors, thereby in some measure preventing damage to the wooden trays and tables. These ball feet remained in constant use until the termination of the industry, notwithstanding repeated attempts on the part of the “Claw and Ball” and “lion mask” varieties of patterns to elbow them out of existence.

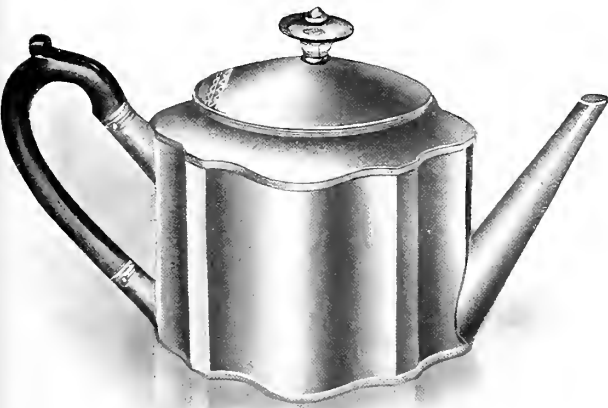

3-gill Shaped Sided Plain Teapot, by Younge, Greaves and Hoyland.
Date 1789. Coopland, Sheffield



3-gill Octagonal Sided Teapot, with engraved band and soldered-in shield, by D. Holy, Wilkinson & Co.
Date 1788. Elkington, London.



3-gill Oblong Teapot, engraved silver band, with soldered-in shield, by D. Holy, Wilkinson & Co.
Date 1789. Author.

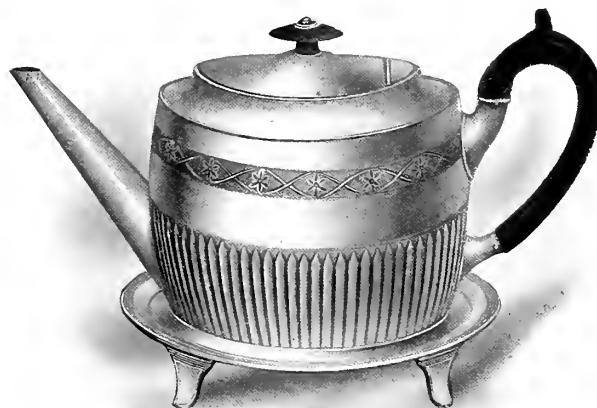

Oval Fluted Teapot, extra heavily plated, with engraved silver band and straight flutes, on stand, by Watson & Bradbury.
Date 1797. Hall, Louth,



5-gill Oblong Teapot, on fixed stand, with ball feet and soldered-in shield, by N. Smith & Co.
Date 1801. Martin & Co., Cheltenham.



6-gill Oblong Teapot, with light shell and gadroon border, by D. Holy, Parker & Co.
Date 1805. Author.



4-gill Teapot, highly ornate, with chased body and claw feet, by Watson & Bradbury.
Date 1818. Author.



4-gill Oblong Florid Teapot, on ball feet, by Gainsford & Nicholson.
Date 1820. Mr. A. Nicholson, Sheffield.



6-gill fluted Teapot, on ball feet, by Gamsford & Nicholson.

Date 1815.

Mr. A. Nicholson, Sheffield.



5-gill plain Coffee Jug, with covered Sugar and Milk Jug to match, by B. Rooke & Son.

Date 1829.

Author.



4-gill Tea Service, heavily mounted and fluted, Teapot has a metal handle, a scarce example of the highly ornate period of decoration, by Watson, Pass & Co.
Date 1817.

Author.



Coffee Service.—Coffee, 5 gills; Teapot, 4 gills, with metal handles, by B. Rooke & Son,
Date 1818. Birch & Gaydon, London.

TEA URNS.

Hot water, coffee or tea urns held a place on the sideboards of the wealthier classes from about the middle of the 18th century. Their earliest association with Old Sheffield Plate was about the year 1762* and they are scheduled in the list of articles produced by the old platers in the year 1774. Small Old Sheffield tea urns, of this period, holding about two to three quarts, are greatly prized by collectors, and very large prices are realised when those in good condition are offered for sale. Like many other Old Plated articles these urns, with the introduction of the heavy florid mounts, grew to enormous proportions, so much so that it must have been exceedingly difficult for the strongest of butlers to lift them when full, and further weighted by their iron heaters.

The tea urns were made first of all without any heating accessories. Then appliances were introduced for keeping the water hot by the aid of a heating iron fixed in the upper part of the base. This iron penetrated into the lower part of body and was secured as in illustration on page 361. One curious urn is illustrated in detail on the two subsequent pages. On the top of the detached base will be seen a round perforated container, made of iron, in which was deposited hot charcoal. From this came a tube, fixed on to the base, which ran right up the body of the urn, carrying the heat from the charcoal through the body, and also facilitating complete combustion. The lid fitted closely round this tube. The knob was removable and adjustable by the aid of a catch, which can be seen in the illustration.

A later mode of heating tea urns was by means of a separate piece of iron in the form of a small ingot which was made red hot and then deposited in a separately fastened-in jacket, this jacket being nearly always found soldered inside the tea urns made after the year 1800. The method of heating by red hot irons was sometimes applied to entrée dish warmers made before the year 1800. Tea urns with lamps and burners are by far the most satisfactory in use, but in Old Sheffield Plate they are scarce. This is perhaps to be accounted for by the high price prevailing in former times for spirits of wine.

* See Illustration on page 160.



4-quart Tea Urn, 19½ in. high, with charcoal method of heating, on pierced stand with ball feet.
The body slightly chased in high relief, stained green ivory thumb-piece attached to tap, and
green ivory supports to handles.

Date 1767.

Author.



4-quart Tea Urn, showing the removable sections. Urns fashioned in this manner and similar in design made entirely of unplated copper (but with cast handles, spout, mounts, etc.) have also been met with. These were most probably made in London between the years 1760-1770.



1-quart Adam Tea Urn, 14½ in. high, with flat chased decoration, dolphin spout and shell knob,
by T. Law & Co.

Date 1778.

Author.

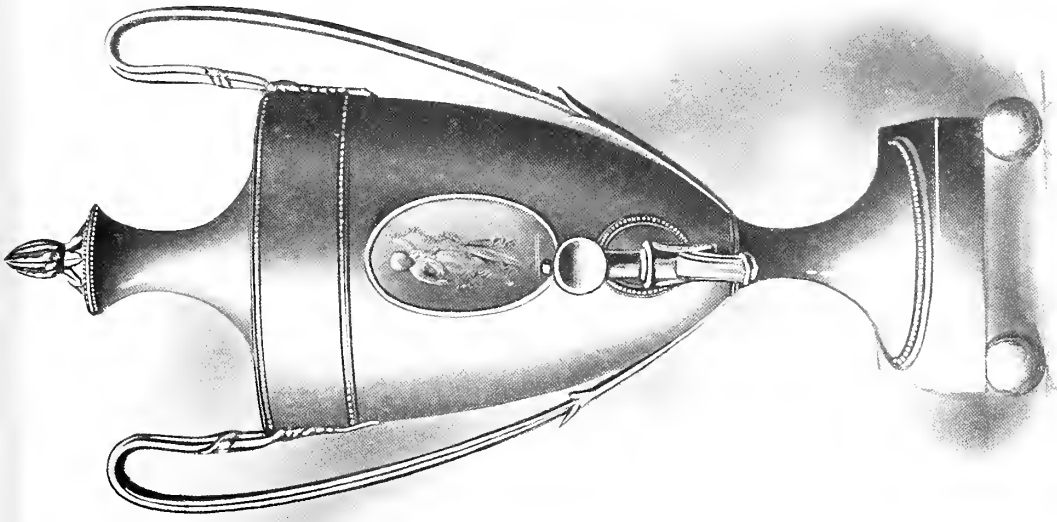

4-quart Tea Urn, with Flaxman medallion,
by J. Younge & Co.
Date 1784
Warren, Sevenoaks.

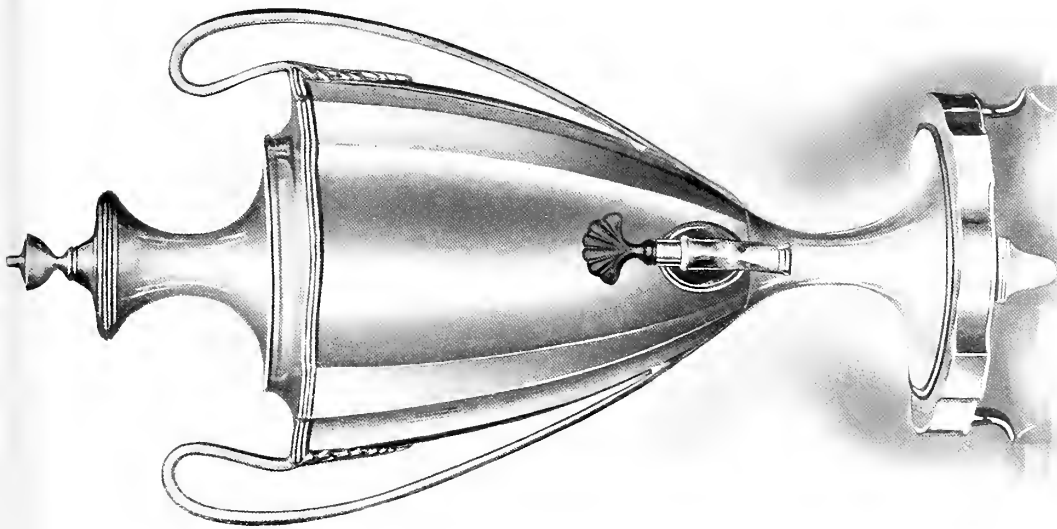

3-pint Tea Urn, with shaped sides, on fixed stand with four feet,
by Watson & Bradbury.
Date 1795.
Mr. Arthur Parsons, London.

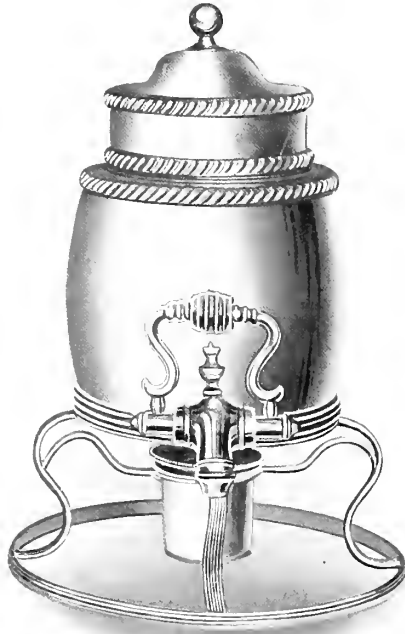

3-pint Coffee Urn, with gadroon mounts and lamp, on loose stand, by Matthew Boulton, Birmingham.
Date 1805.

D. & M. Davis, Birmingham.



2-quart Tea Urn, with fluted mounts and claw feet, by Watson, Pass & Co.

Date 1818.

Oswin & Co., Hereford.



Tea Urn, with heater, made about the year 1825. The Tap of electroplated German silver has probably been added some 20 years later. The original tap would no doubt be struck from a die and fitted with filled silver handle supports in keeping with the character of the urn (see page 144), by Watson & Bradbury.

Col. H. C. Surtees, Durham.

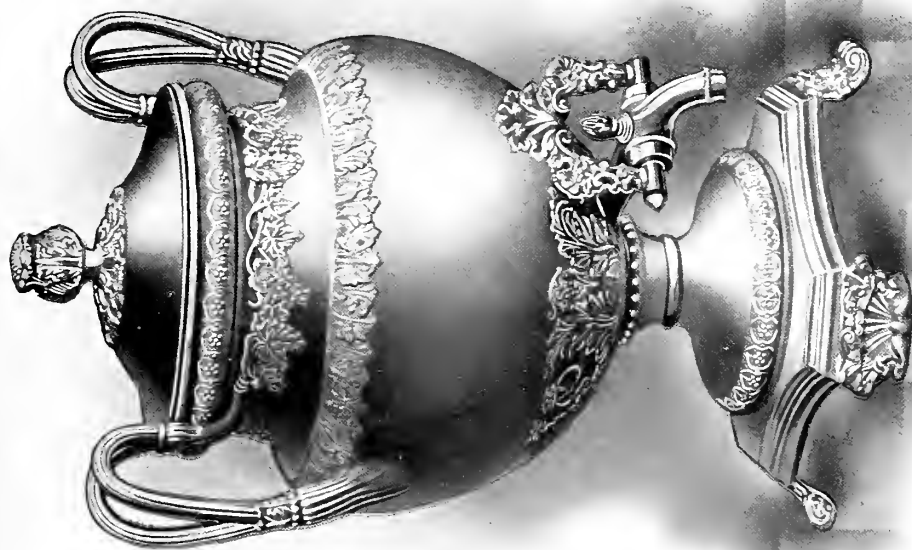

6-quart Tea Urn, in the form of a Grecian vase (the same design was adapted for wine coolers), by Kirkby, Waterhouse & Co. (see page 383).
Date 1820.
Withers, Leicester.

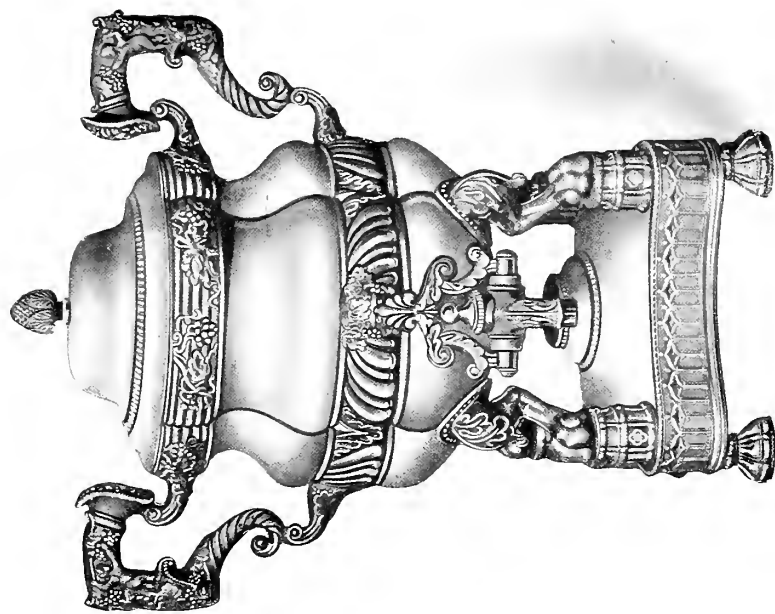

4-quart Tea Urn, with lamp on pedestal, supported by four claw legs, Bacchanalian design, of fine workmanship (the same pattern was also adapted for wine coolers),
by Watson & Bradbury.
Date 1812.
Author.

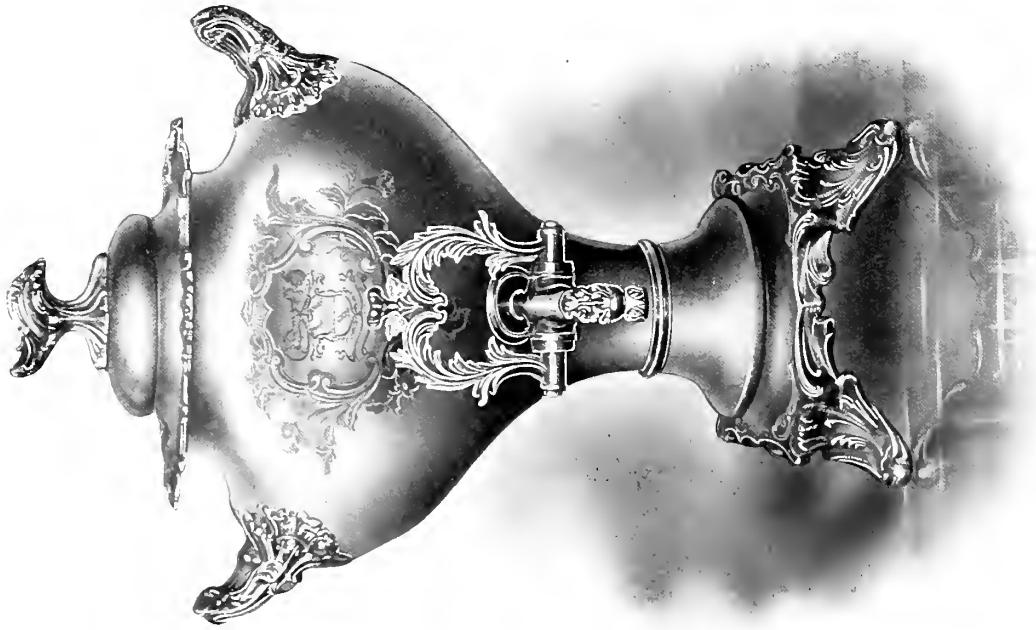

3-quart Tea Urn, with decorative ornaments in the rococo style,
by T. & J. Settle.
Date 1830.
Warren, Sevenoaks.

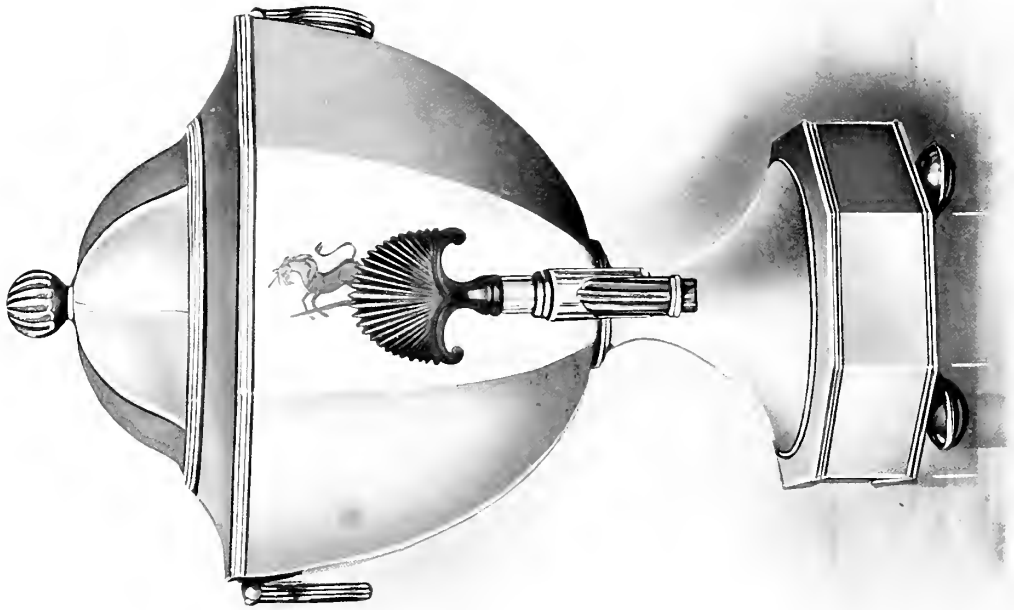

5-pint Octagonal Tea Urn, by Roberts, Cadman & Co.
D. & M. Davis, Birmingham.
Date 1789.



The "Tea Machine," height 24 in. by 20 in., 19 in. front to back (weight 32 lbs). Plating of extra thickness to allow for the deep cut engraving. Consisting of large Hot Water Urn, holding 6 pints, and two smaller Urns 3 pints each. The Tea and Coffee Machines would be in use on the breakfast table, in large country houses, in the early part of the 19th century. (For further description see page 416), by D. Holy, Wilkinson & Co.

Date 1798.

Thomas & Co., London.

TOAST RACKS, EGG FRAMES, EGG BOILERS, AND THEIR VARIOUS COMBINATIONS.

Toast racks—toast trays, as they were termed—or egg frames are not mentioned in the list of articles produced by the old platers in the year 1774. It may have been that their manufacture then was too trivial to have attracted attention. Nevertheless we find such small articles as scallop shells, wine funnels and skewers are given a place in the list. It would not be far outside the mark to place the date of the introduction of egg frames and toast racks—so far as the plated trade is concerned—contemporarily with the improved invention of plated wire, i.e., between 1780 and 1785.* Samuel Roberts took out a patent for his folding toast tray in the year 1807;† other designs there were for folding racks that apparently were not patented, one of which is illustrated at the foot of page 369.

With regard to the egg cup, toast rack, salt cellar, etc., combinations, all the firms were manufacturers of these in various patterns, each with a style of their own. Amongst the 65 egg frames listed on page 197, a very large proportion are composed of these combined articles.

Perhaps the makers of Old Sheffield Plate would take their ideas of construction from the many varied productions that Thomas Sheraton was turning out in furniture during the same period. Sheraton was born in the year 1750 and died in 1806. His book on furniture published in 1793 testifies throughout to his ideas of economy of space and utility of purpose. The feeling that can be traced in the invention of this furniture may possibly have also influenced the designers of these plated articles of domestic utility, since they were used in conjunction with each other.

In any case, Sheraton's productions were contemporary with these composite articles made in Old Sheffield Plate, such as combined *épergnes* and cruets; egg frames with spoons, salt and pepper; toast racks with pepper, salt, and egg cups; supper services with soup tureen, entrée dishes and salt cellars; tea and coffee machines; inkstands with wafer box, taper, etc., etc., and many other ideas that were apparently carried out by the old platers, and not usually found made by the contemporary London silversmiths towards the termination of the 18th century.

* The majority of Sheffield Plate Toast Racks and Egg Frames of the earlier period are composed almost entirely of wire.

† These usually bear the mark "R. C. & Co., Patent."

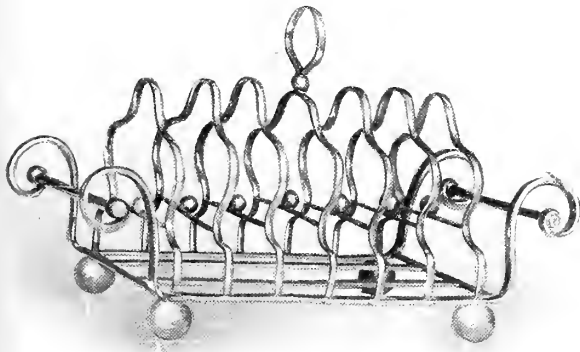

7-bar Toast Rack, by A. Goodman & Co.
Date 1805. Author.

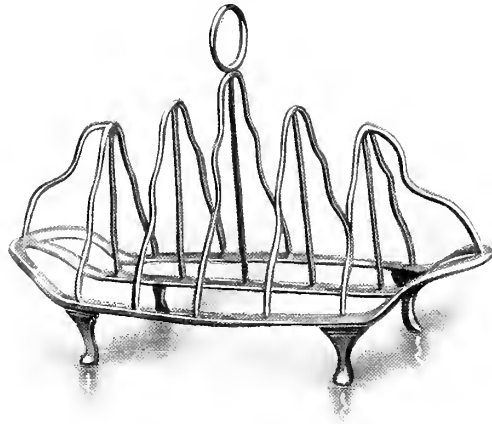

5-bar Shaped Gothic Toast Rack, by Watson & Bradbury.
Date 1797. Hunt, Preston.



Patent Folding Toast Rack, by Roberts, Cadman & Co.
Date 1807. Robinson & Co., Shrewsbury.

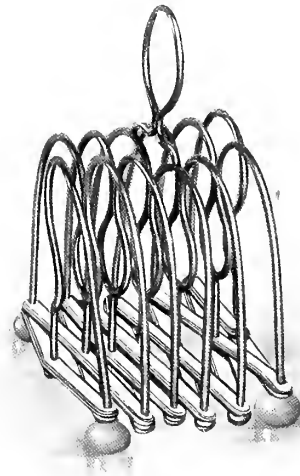

Patent Folding Toast Rack (closed).

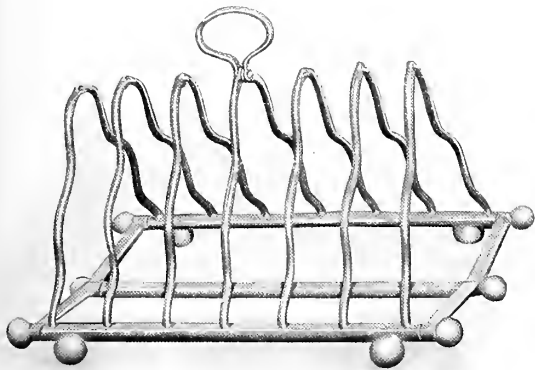

Folding Toast Rack, by A. Goodman & Co.
Date 1808. Robinson, Northampton.

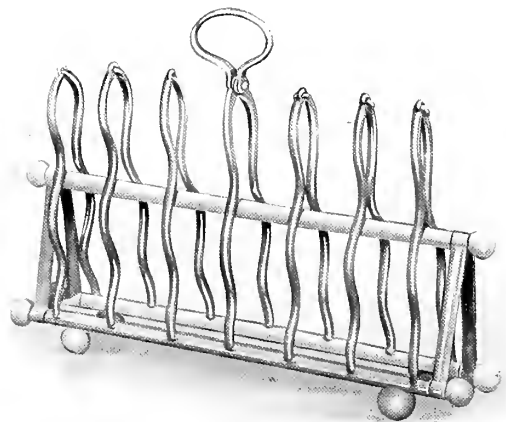

Folding Toast Rack (closed).

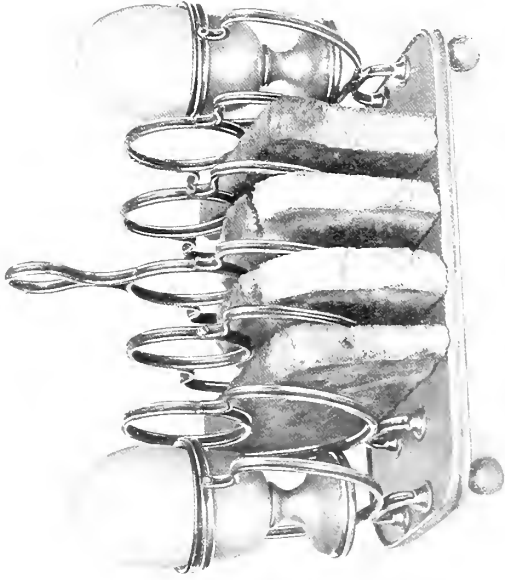

Folding Toast Rack, showing combined use for eggs and toast.

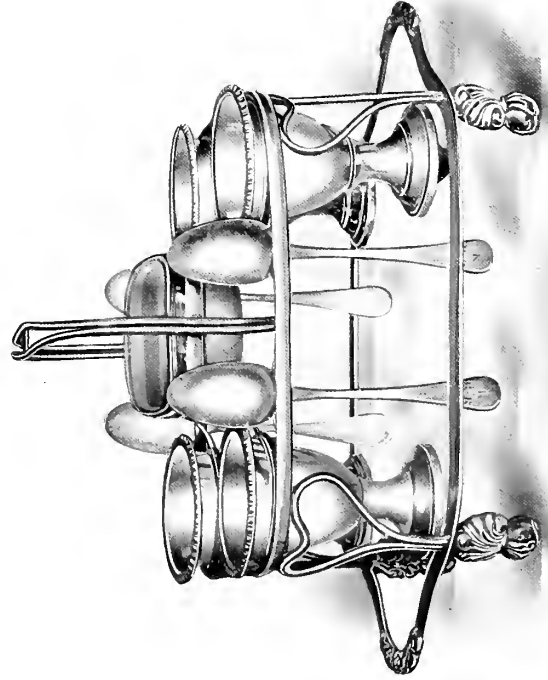

4-Cup Egg Frame and Spoons Combination, with salt in centre, by G. Eadon & Co. Date 1805. Davis, Manchester.

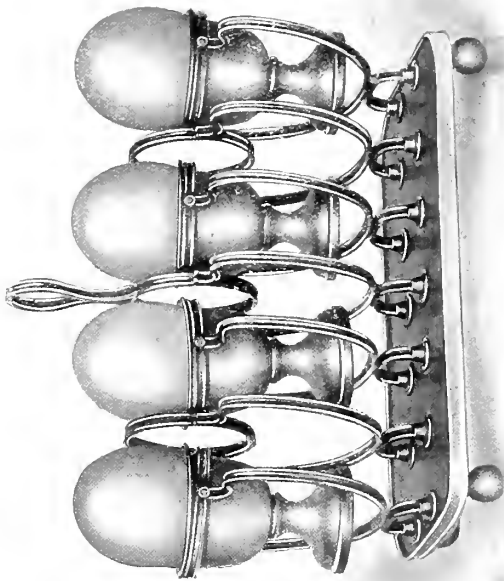

Folding Toast Rack and Egg Cup Combination, by N. Smith & Co. Author. Date 1808.

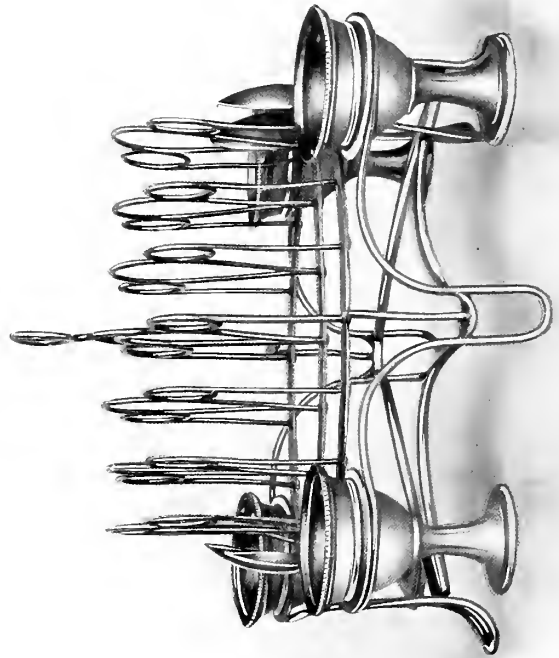

7-Bar Toast Rack and Egg Cup Combination, with Spoons, by Watson & Bradbury. Date 1798. Mr. J. C. Bethell, Tadcaster.

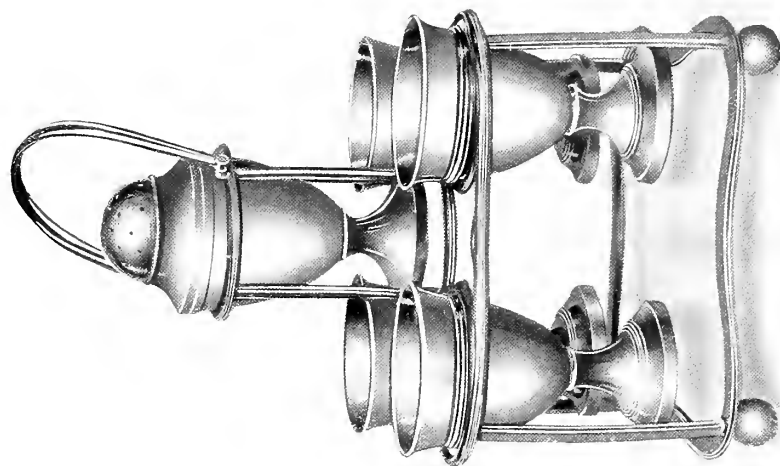

4-Cup Egg Frame, with centre pepper, by
Watson & Bradbury.
Date 1802 D. & M. Davis, Birmingham.

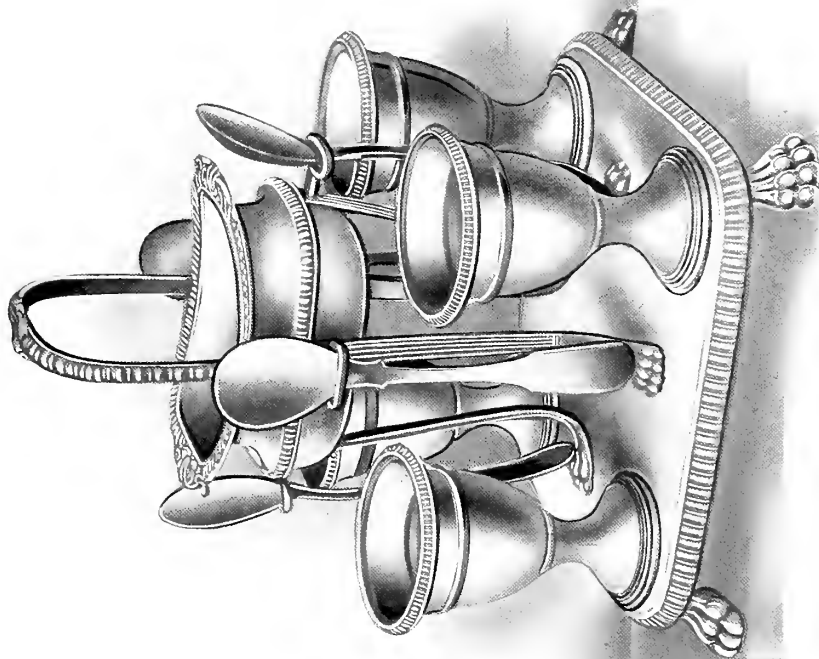

4-Cup Egg Frame, with spoons and centre salt, by
A. Goodman & Co.
Date 1806. Thomas & Co., London.

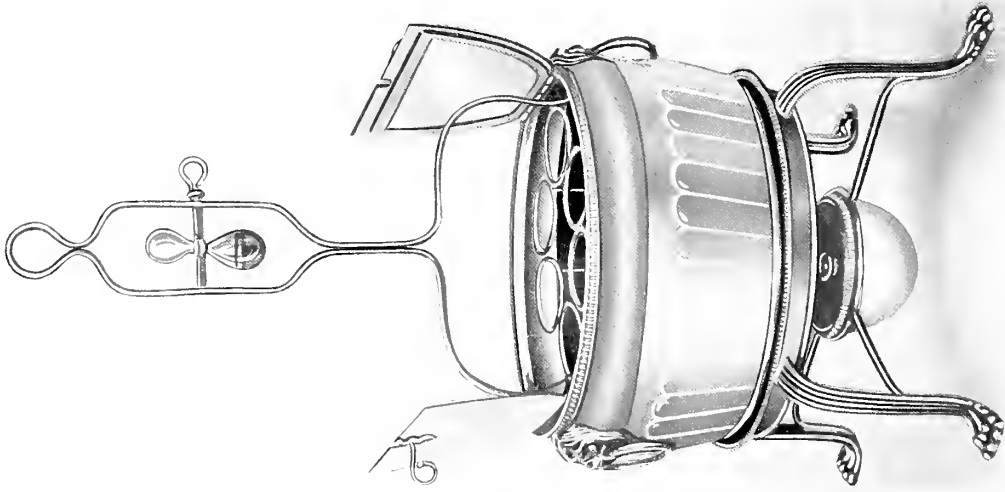

Round 6-cup Egg Boiler with Timer, by Roberts, Cadman & Co.
Elkington & Co., London.
Date 1798.

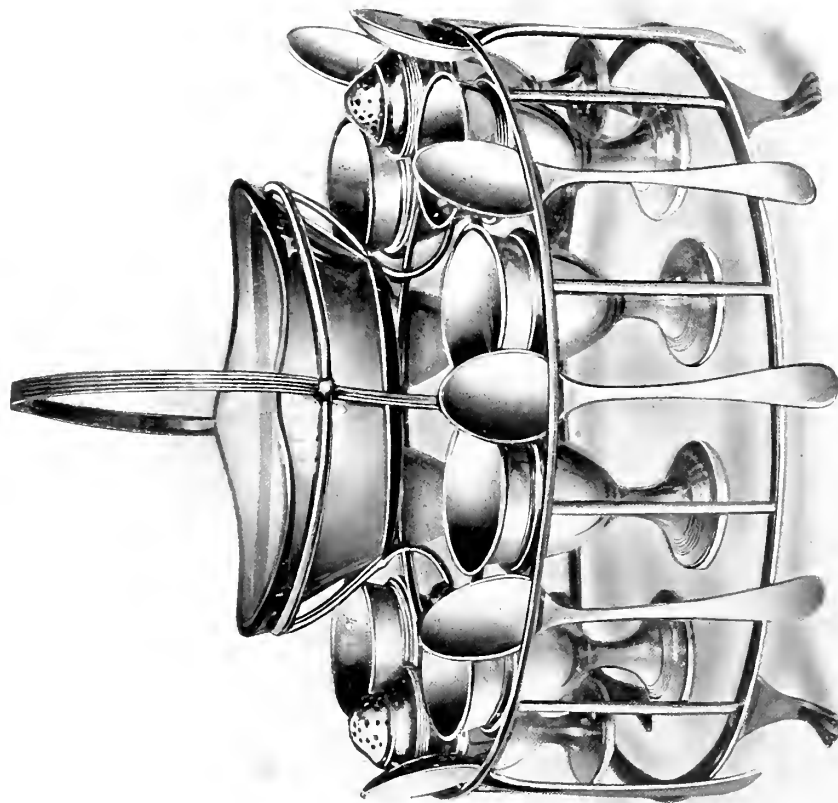

Large Wire Work 8-cup Egg Frame, with eight spoons, two peppers, and one centre
glass salt cellar, by N. Smith & Co.
D. & M. Davis, Birmingham.
Date 1792.

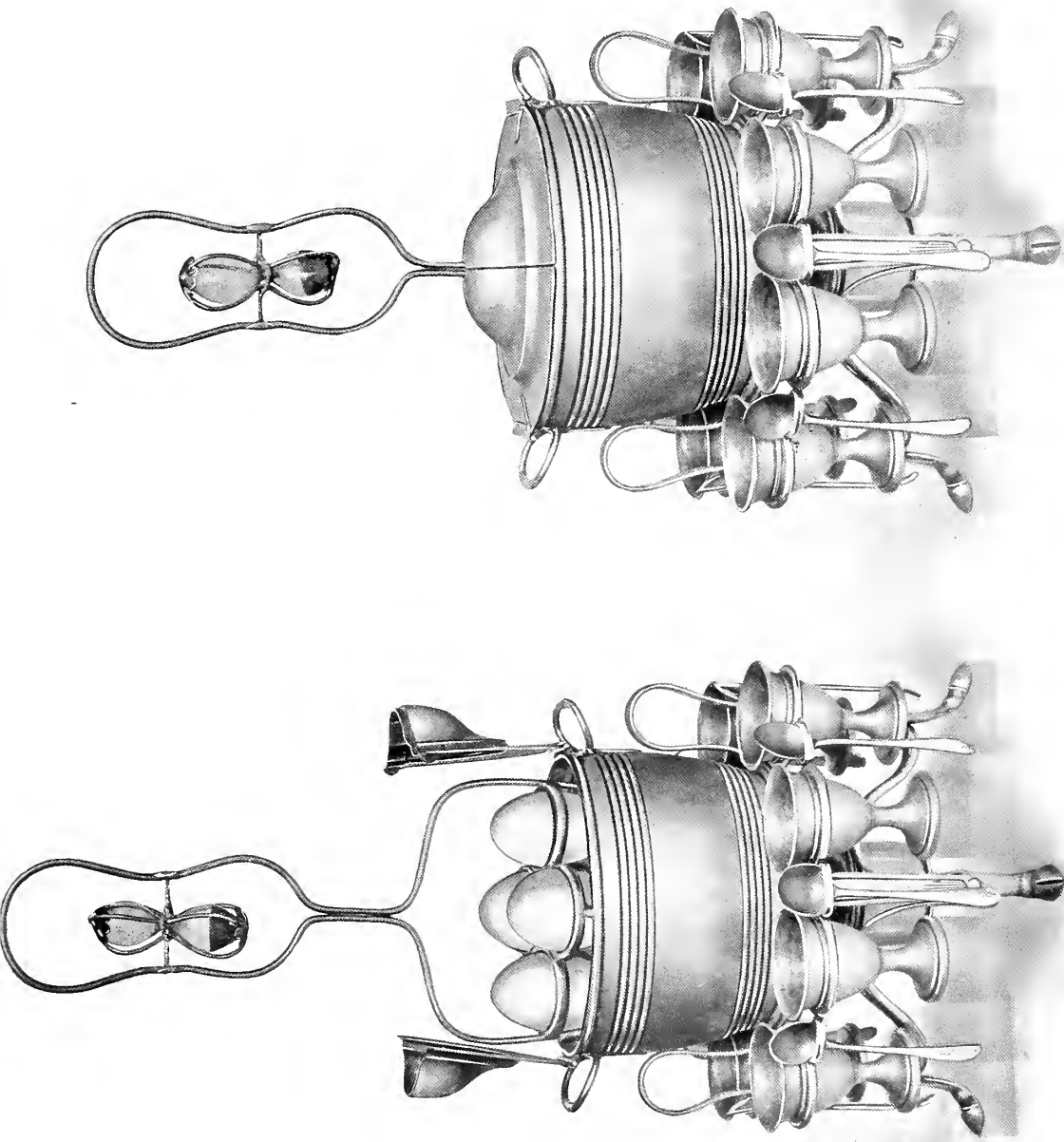

Egg Boiler for eight eggs, with eight cups and spoons, also Timer, by Watson & Bradbury.
Elkington & Co., London.
Date 1795.

TOBACCO AND CIGAR BOXES. PIPE LIGHTERS. TINDER BOXES.

A very fair trade was done by the Old Sheffield platers in the making of boxes for tobacco and "segars boxes," as they were described. Besides being a very pretty table ornament at night in the olden days, the tobacco and cigars kept remarkably well in these boxes, which were so cleverly fitted as to be almost entirely air-tight. With these are illustrated pipe lighters; as to the purposes they were intended to serve much discussion has arisen. Sometimes they are described as chestnut dishes or sweetmeat dishes. As, however, the feet have been rivetted to the dishes and screwed to the waiter plates underneath them—and as they contain a separate copper lining—it is manifest that they were for holding peat or some other combustible.

Mr. H. C. Casley says: "I cannot say whether in former times they were in use in the coffee houses and clubs, but I know that they were made for the Dutch market, being used in comparatively modern times. A Belgian artist who used to visit our house when I was a boy brought all kinds of funny heater arrangements for the table from his country, and it almost invariably turned out that they were made in Sheffield."

Not until the year 1835 was anything in the form of matches in use in the household. We are told though that tinder boxes died hard. House-

maids were human beings and conservative, and at first grumbled lustily over the new method of striking a light and attributed the discovery of matches to diabolical agency. The tinder box therefore lasted on for some considerable time after the introduction of matches, whilst it possessed one advantage over subsequent light-producing discoveries—it was not irremediably ruined by wet. The one here illustrated, being so small, was perhaps made for a special purpose. The making of tinder boxes in Old Sheffield Plate cannot have been a regular trade as they are



Tinder Box, with nozzle for a taper fixed on lid.
3½ in. × 3½ in. tinned inside.

Date 1800.

Author.



Tobacco Box, fixed on 7 in. pierced border waiter capacity $\frac{3}{4}$ lb., by J. Younge & Co.
Date 1783. Mr. Hamilton Blake, Edinburgh.



Tobacco Box, capacity 1 lb., $3\frac{1}{2}$ in. high by $5\frac{1}{4}$ in. across.
Date 1802. Author.

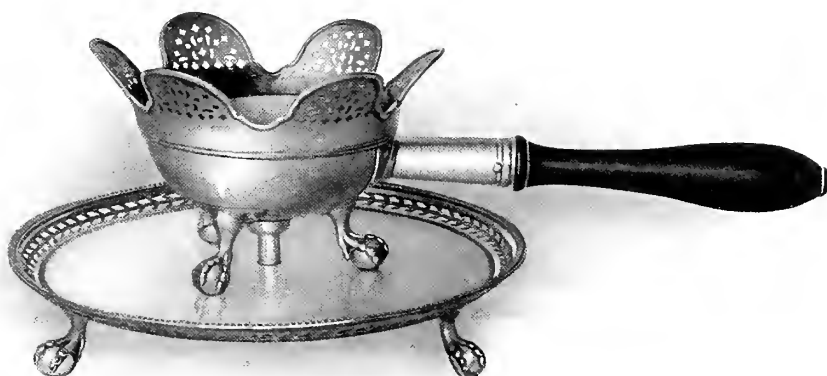

Pierced Escalloped Top Pipe Lighter, with loose copper lining—feet riveted to body—on 7 in. pierced border waiter plate.
Date 1783. Mr. B. B. Harrison, Sevenoaks.



Pierced Border Pipe Lighter, $4\frac{1}{2}$ in. high, with loose copper lining, screwed on to 7 in. pierced border waiter plate, by G. Ashforth & Co.
Date 1786. Cambray, Oxford.



Fluted Cigar Holder, with bone mouthpiece, $2\frac{1}{4}$ in. long.
Date 1800. Mr. H. Hunt, Sheffield.

very scarce, neither is there mention of them made in the old pattern books. Usually they were constructed of wood 8" x 5", 2" deep and divided in the middle, one compartment contained steel, flint, and strips of wood, the ends thereof having been dipped in brimstone; the other, tinder and damper.



Mahogany Case, containing silver mounted meerschaum pipe, hall marked in 1820, and an Old Sheffield Plate tobacco box, with pull off top. Formerly the property of Lord Byron.

Date 1820.

Author,

WINE COOLERS.

Described as "ice pails" in old pattern books, these articles were scarce before the year 1800, in Old Sheffield Plate. Indeed it may be said that before the year 1780 they are hardly to be found at all. The 1774 list omits altogether any note of their existence at that date, and it is not until about the years 1815-25 that they assumed the important position on the sideboards of that time that had previously been held by the old Chippendale and Sheraton knife boxes. To-day the prices of Old Sheffield wine coolers in good condition have advanced considerably on those given ten or fifteen years ago. The highly ornate productions of the late Georgian period are still the most popular with collectors. It is somewhat of a surprise to find that the bulk of the wine coolers now so greatly in demand were manufactured in comparatively recent times, and the majority of them by only two or three of the Old Sheffield houses, who appear to have specialized in this class of wares. The wine coolers made to-day are generally destined for use in hotels and on board ships.

Heavily mounted articles, and more especially wine coolers, are well worth the prices now obtained for them, as their manufacture marked the culminating point of the platers' craft. It is extremely doubtful if the resuscitation of fused plated wine coolers (even supposing the dies formerly used in the various parts of their construction to be still in existence) is at all within the bounds of possibility.

Wine coolers were not by any means the cheapest of articles made in Old Sheffield Plate, and looking through the catalogue of Messrs. I. & I. Waterhouse & Co., we find that 16 guineas a pair was considered a fair wholesale price to ask for the most ordinary of the patterns made by this firm, whilst as much as 20 guineas per pair was asked for the one illustrated on page 383, in the form of a Grecian vase.

An exceedingly pretty style of wine cooler was made between the years 1788-94, having soldered-on broad silver bands with deeply cut bright engraving thereon. Chiefly manufactured by Danl. Holy, Wilkinson & Co., Matthew Fenton & Co., and Nathaniel Smith & Co., these are rather scarce.

THE WARWICK VASE.

Reproduced to serve as a wine cooler, there is no doubt that to a certain extent the vase loses a good deal of its original conception as to shape, but, nevertheless, any collector possessing a reproduction in this form of the celebrated Warwick Vase in Old Sheffield Plate is indeed fortunate.

The prices given for these beautiful specimens of Sheffield workmanship have gone up by leaps and bounds during the last ten years. One hundred guineas would not be one whit too much to-day at which to appraise the value of a pair of these vases—generally adapted for the purpose of wine coolers—if in perfect condition. The wholesale prices quoted in their catalogues by the makers of these vases, I. & I. Waterhouse & Co.,



Wine Cooler, 10 in. high, in form of the Warwick Vase, by I. & I. Waterhouse, marked with crown.
Date 1820—1830.

Mr. A. J. Hobson, Sheffield.

are 32 guineas a pair, and the date of their original manufacture must have been about the years 1820-30. Some models of the Warwick Vase, struck with this firm's mark, are also to be met with as tea urns and soup tureens, in which capacities they are by no means so pleasing as in the former case.

One must excuse the manufacturer—who had gone to so great an expense in cutting the dies for these vases—for making whatever use he could out of

the models. It would cause no great surprise, therefore, to meet with other articles in Old Sheffield Plate besides those enumerated, in the form of the Warwick Vase. Those found marked with the fleur-de-lis cannot have been made before 1833, the date of registration of this mark by Waterhouse. Those marked with the crown were probably made nearer the year 1820.



Tea Urn, 17½ in. high, in the form of a Warwick Vase, by I. & I. Waterhouse & Co., marked with fleur-de-lis.
Date 1833.

Author.

As to the origin of the "reproduction" of the Warwick Vase we are indebted to "Sir E. Thomason's Memoirs of Half a Century."

"In the latter end of June, 1813, there was much talk that the Earl of Warwick had at last permitted a model of the splendid vase at Warwick Castle to be modelled on the spot, provided Lord Lonsdale would have it made in silver; to this Lord Lonsdale acquiesced, and his lordship thought he had settled with Messrs. Rundell & Bridges that the charge, including all expenses, would not exceed £30,000. Messrs. Rundell & Bridges, before completing the contract, requested to send down their principal modeller to the Castle to make a wax model of it; the difficulty and expense which they perceived they should have to encounter in the casting of so large a surface in silver led them to state to his lordship that the estimate must be £30,000, £5,000 *more or less*.

Now Lord Lonsdale did not approve of the words 'more or less,' and seeing that there were doubts of the possibility that this gigantic specimen of plate could ever be effected, the treaty was abandoned altogether. What charge Messrs. Rundell & Bridges made for the great model which was near completion, I never satisfactorily heard, but I think Messrs. Rundell & Bridges were quite consistent in requiring the latitude mentioned."

The vase was eventually copied by Sir E. Thomason, after much discussion, in bronze. This was considered to be in better taste than making it in solid silver. However, it took seven years before completion, the gigantic task being eventually brought to a conclusion about the year 1820. One of these vases by Thomason, in bronze, is now set up at Cambridge, in front of the University Library, whilst another is placed in the entrance of Aston Hall, Birmingham. Smaller editions of the vase, capable of holding about five quarts, were made in silver by both Thomason and Rundle & Bridges. Then followed their production in Sheffield Plate by Waterhouse.

The original of this vase stands in the grounds of Warwick Castle. The workmanship is carried out in white marble, and has been attributed to Lysippus, who flourished in Greece 325 years before the Christian Era, and in the age of Alexander the Great. According to Smith's Directory of Greek and Roman biography, Lysippus worked almost entirely in bronze, so that the attribution of the vase to him is perhaps open to doubt. By others it is said to have been made for, and during the reign of, the Emperor Hadrian, A.D. 117—138. The dimensions are as follows: extreme height

5 ft. 7 ins., diameter about 8 ft., capacity 163 gallons. It was discovered, in 1770, in the course of draining the Lake of Pantanello, in the precincts of Hadrian's villa, near Tivoli. Sir William Hamilton, ambassador to the Court of Ferdinand IV., King of Sicily, purchased it and brought it to England in 1774; sometime later it was sold to the Earl of Warwick and placed in the grounds of Warwick Castle, where it has remained ever since.

The vase is in the form of a crater, the lower portion being extended and decorated round its base with acanthus foliage, slanting upwards, above which, spread out on a kind of shelf, lies a panther's skin, the head and legs drooping over the bend of the lower portion of the body of the vase. Above this, the centre or main part of the body or bowl of the vase turns inwards until it assumes the form of a ledge, covered by the panther's skin. On this ledge repose, on either side of the vase, four Bacchic masks. In the centre, and on a separate low plinth, is a head of Dionysius crowned with ivy, and another of the bearded Silenus; in front of each is a short thyrsus laid slant-wise; on the left and right a bearded Satyr head, the one to the left crowned with ivy, that to the right with pine sprays. On the opposite side, in the centre, also on a low plinth, is another head of Dionysius, bearded, but without a wreath, and beside it on a plinth a female head crowned with ivy; beside them on the left is a pedum, on the right a thyrsus; at either end a bearded Satyr head, that on the left bald-headed and crowned with ivy, that on the right crowned with pine leaves. At either side of the vase are attached twisted handles in the form of vine branches, starting towards the base and terminating on the upper ledge of the body just underneath the mount and winding their way completely round the vase, decorated with entwined vine leaves and bunches of grapes. The vase is mounted with a combined bead and egg and tongue moulding. On its discovery the vase was in fragments, and an artist in Rome was commissioned by Sir W. Hamilton to restore it and supply the deficient masks. This restoration cost him over £300.*

It is said that had the Emperor Napoleon been successful in conquering England, the first note entered in his pocket book was to possess himself of the marble vase at Warwick Castle. None other ancient vase, it is said, its equal in size and workmanship is known to exist.

* It is generally accepted that the mask of a female on one side of the vase is not original, and that when undergoing restoration the artist, out of compliment to Sir William, took copy from the head of his wife, "Emma Hamilton." If this is true the vase underwent restoration many years after its original discovery.



Wine Cooler, in Old Sheffield Plate, with mask handles (very similar in style to silver one), by Watson & Bradbury.
Date 1800. Author.

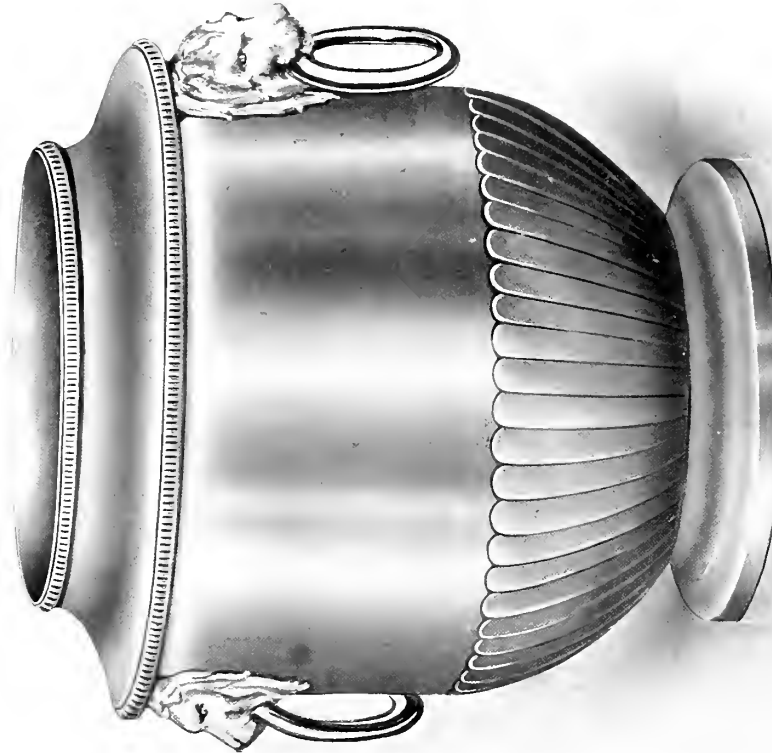

Fluted Wine Cooler, in silver, with mask handles, presented to Lord Nelson in 1801, to commemorate the Battle of Copenhagen.

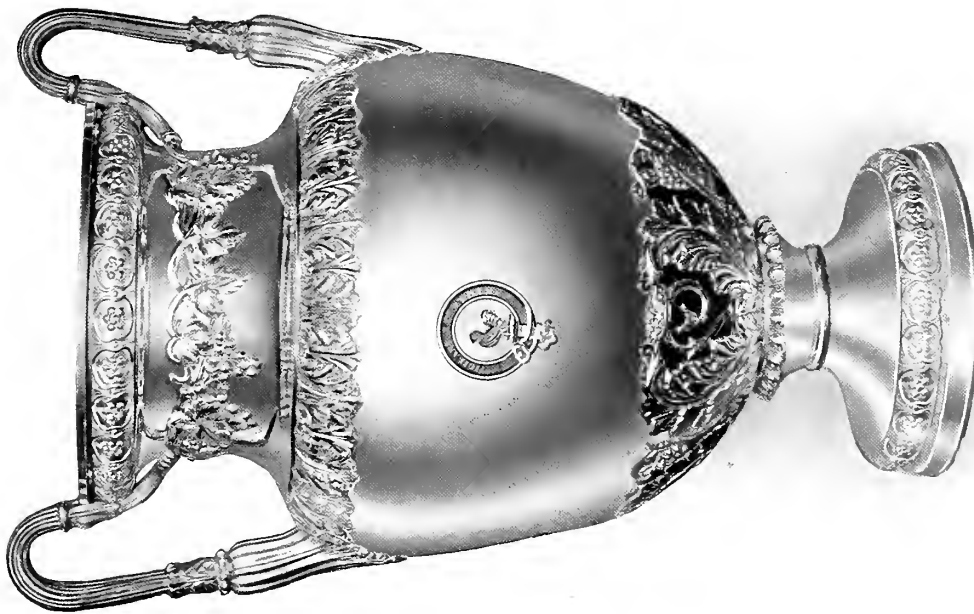

Wine Cooler, in form of a Grecian vase, 14½ in. high, by Kirkby, Waterhouse & Co. (see Urn, page 365).
Date 1817.
Lake & Son, Exeter.

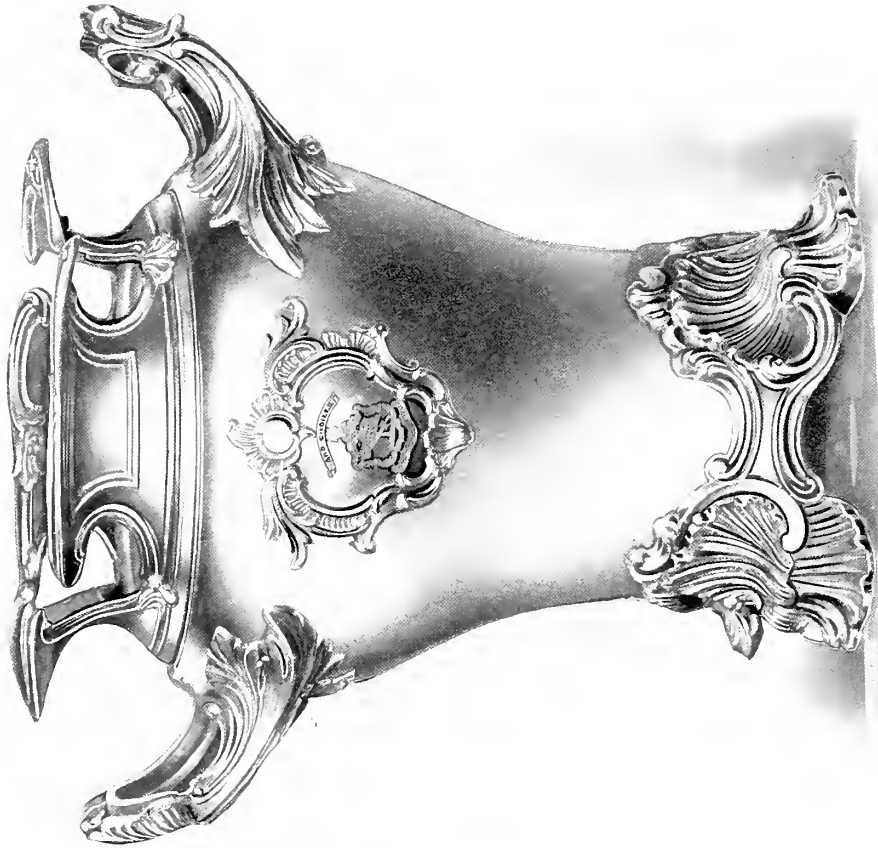

The Monteith Wine Cooler, 10½ in. high, with partitions for glasses, and removable rim, silver shield soldered on separately.
Date 1820.
Mr. N. Haggie, Whitburn.



Wine Cooler, with mask handles, and soldered-on silver shield,
by Roberts, Cadman & Co.

Date 1795.

Reed, Liverpool.



Plain Wine Cooler, with gadroon mount, by
S. Kirkby & Co.

Date 1803.

Davis, Manchester.



Wine Cooler, with thread mounts and mask handles, by
T. Law & Co.

Date 1810.

Author.



Wine Cooler, oblong in shape, with gadroon and shell
mounts, by N. Smith & Co.

Date 1812.

Robinson, Northampton.



Wine Cooler, 10 in. high, with fluted body, shell and gadroon mount.
Date 1815. Paget, Cheltenham.



Wine Cooler, 10 in. high, with acanthus decoration and vine border, by Kirkby, Waterhouse & Co.
Date 1817. Mr. H. C. Casley, Ipswich.



Wine Cooler, 11½ in. high, with ring handles and heavy ornate mounts, by Watson & Bradbury.
Date 1819. Lambert, London.



Wine Cooler, 9½ in. high, with heavy ornate mounts, by J. & T. Settle.
Date 1820. Lambert, London.



Wine Cooler, 11 $\frac{1}{4}$ in. high, with mask handle supports and fluted base,
by I. & I. Waterhouse & Co.
Mr. H. Barraclough, Leeds.
Date 1833.

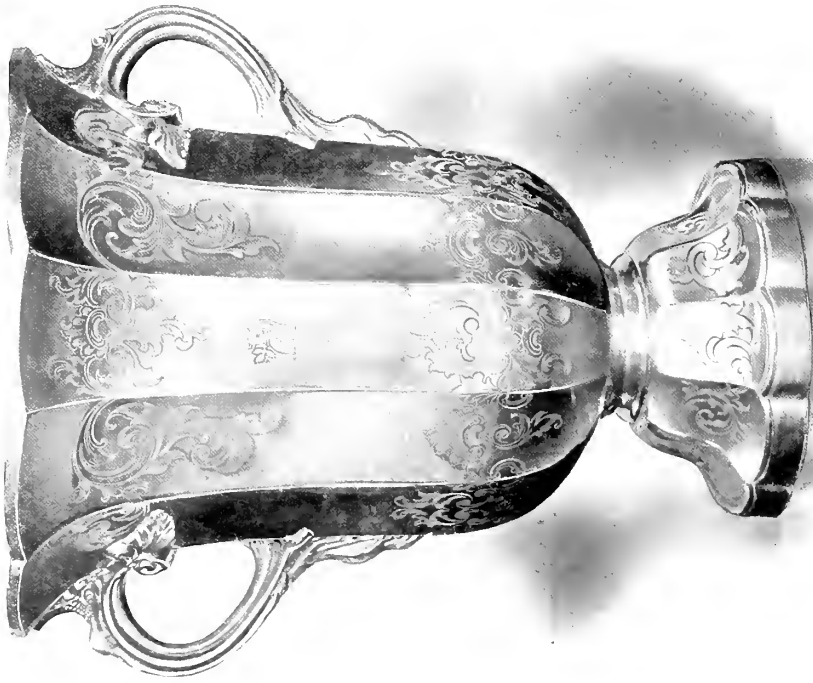

Wine Cooler, 11 in. high, of the transitional period, patent
Argentine or German silver body, fused plated, silver filled
handles and light flat chased ornamentation.
Reed, Liverpool.
Date 1839.

MISCELLANEOUS.

A great number of articles were made by the old Sheffield Platers, for special reasons, or individual requirements. Naturally such did not come within the category of those goods that were wanted for regular household purposes. A few of them are here illustrated, the majority being mainly what would be described as exceptional pieces. Others in this connection were made for or by the opticians, surgical instrument makers, etc., whilst of the remainder, though a few are referred to in Sketchley's list, they are not found in sufficient quantities, nor are they of enough interest to justify their classification with the articles that have been previously illustrated.

Concerning the telescopic toasting fork here illustrated, Sir E. Thomason of Birmingham, in his memoirs, writes, "In 1809 I invented the sliding toasting fork, some with one, two or three slides, within a handsome japanned handle common now in all the shops.



Fused-Plated Folding Toasting Fork, by E. Thomason, Birmingham.

Date 1809.

Mr. A. Westwood, Birmingham.

I also invented one that by the action of drawing the slide the same movement raised a shield from off the prongs, and upon the shutting up again of the slides this action moved the shield over the prongs again.

I also invented a third kind, which was that the three prongs collapsed together, which, on the shutting up of the slides of the fork, drew the same into the mouth of a snake, the head of a silver snake being attached to one end of the outer slide or handle (see illustration above).

The above were made in silver, gilt, plated and brass, and large quantities were sold even by me ; but as I did not protect this invention by patent, thousands were made and sold by other manufacturers."



Small fused-plated Draw Handle, with ring and shield. Handles like this are frequently met with on small cabinets, tea caddies, and writing desks of the Adam period.



Presentation Trowel, 15 in. long, in fused plate, with ebony handle. Author. Date 1835.



Fused-Plated Mace, 36 in long, shaft of turned wood, surmounted by a gold-plated royal crown. Author. Date 1820.



Trowel or Scoop, 5½ in. long, used in former times by the Housekeeper for serving out stores. Date 1800. Blackford, Lynton.



Flask, with cover, 6 in. long, by Tucker, Fenton & Co. Date 1800. Beaver, Manchester.



Sugar Crusher, $4\frac{3}{4}$ in. long, used for Toddy, by T. Law & Co.
Date 1778. Author.



Honey Hive, $5\frac{3}{4}$ in. high, by Watson & Bradbury.
Date 1800. Franklin & Hare, Taunton.

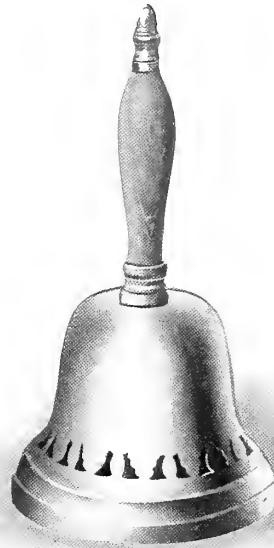
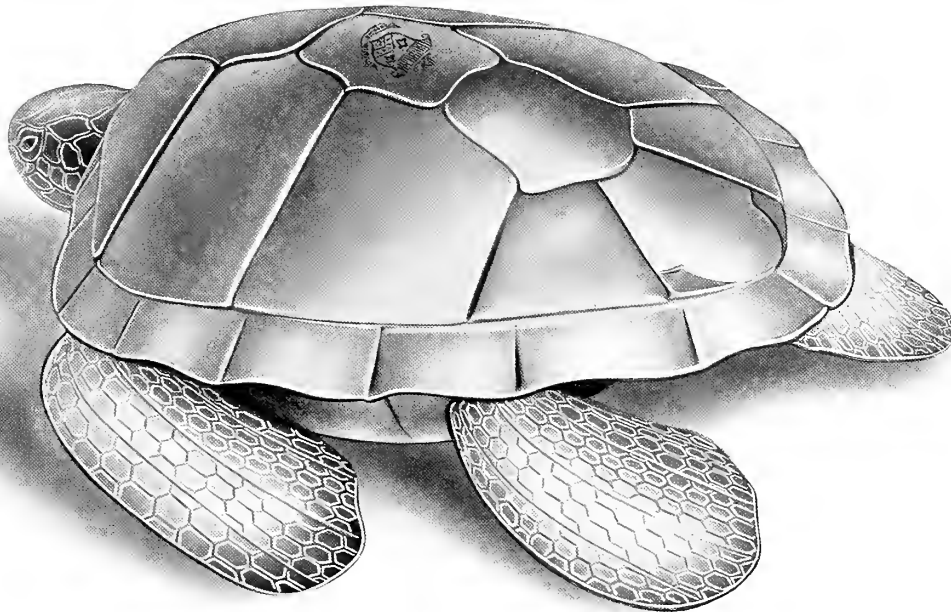
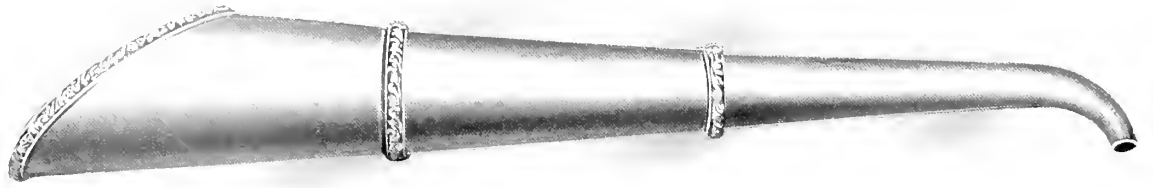

Table Bell, with metal lining screwed inside, and
ivory handle, $4\frac{1}{2}$ in. high, by I. Love & Co.
Date 1789. Mr. H. Hunt, Sheffield.



Soup Tureen, holding five quarts, in the form of a Turtle, 22 in. long \times 17 in. broad.
Date 1798. Elkington & Co., London.



Folding Pocket Ear Trumpet, 12 $\frac{3}{8}$ in. long, with silver mounts, by "W. B. Pine," 352, Strand. Date 1820. Author.

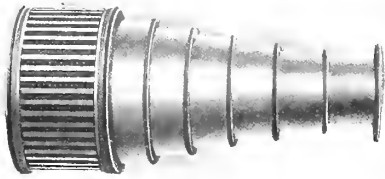

Small Telescope, 4 in. high, extended, by "Gilbert, London." Date 1840. Author.

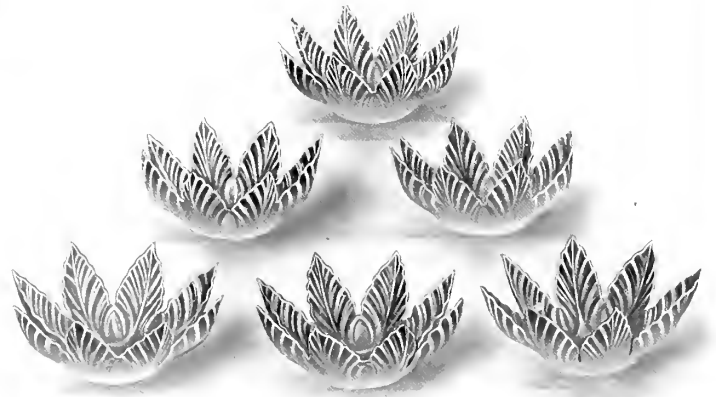

Candlestick Sconces, by J. Parsons & Co. Date 1780. Author.

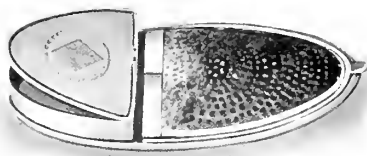

Pocket Nutmeg Grater, for use when making Punch. Date 1790. Mr. H. C. Casley, Ipswich.

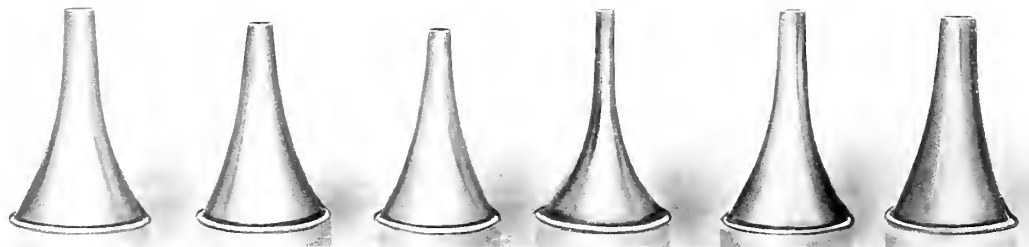

Series of Ear Speculum, 1 $\frac{1}{2}$ in. high. Dr. W. Jobson Horne, London.

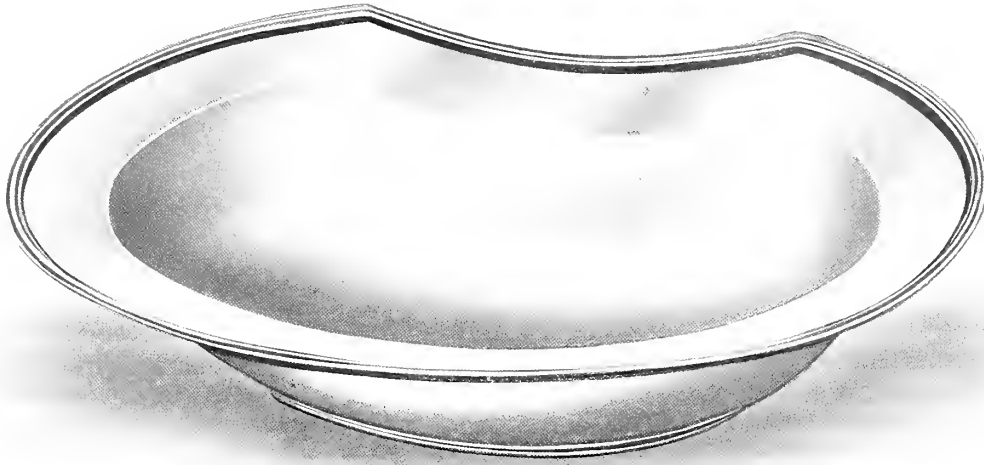

Date 1809.

A Barber's Dish.

Mr. W. H. Willson, Richmond.

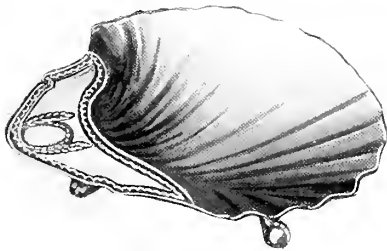

Scallop Shell, chased mount, on claw feet.
by Tudor & Leader.
Date 1778. Heming, London.

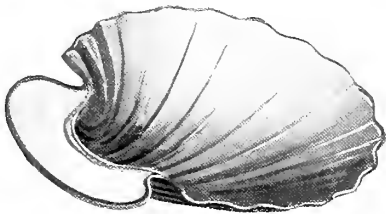

Scallop Shell, chased mount.
Date 1785. Heming, London.

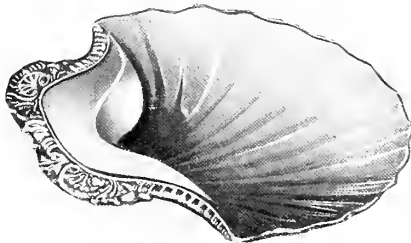

Scallop Shell, with gadroon and shell mount,
by N. Smith & Co.
Date 1812. Heming, London.

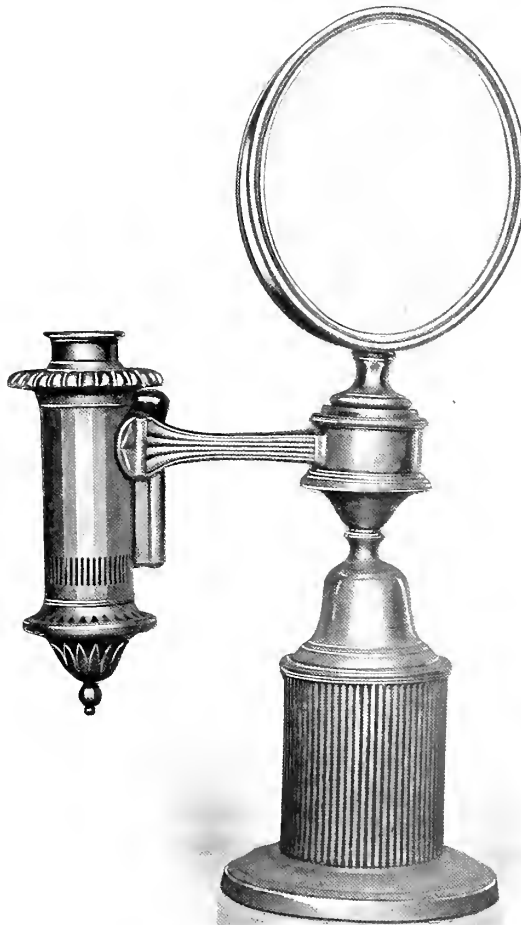

Shaving Lamp, adjustable slide, 16 in. high.
Date 1798. Author.



Pierced Fish Slice, with white ivory handle, silver caps and ferrules, by Madin & Trickett.
Date 1781. Author.

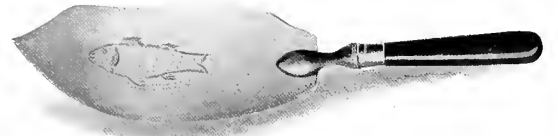

Chased Fish Slice, with stained green ivory handle and silver ferrule, by T. Law & Co.
Date 1790. Author.



Pierced Fish Slice, with pearl (fruit knife) handle, silver cap and ferrule, by John Kay & Co.
Date 1798. Author.

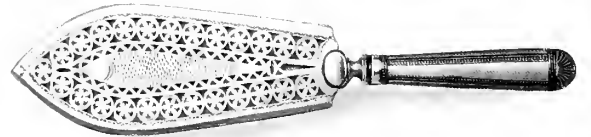

Pierced Fish Slice, with plated handle, by John & Dennis Sykes.
Date 1781. Mr. Dudley Westropp, Dublin.

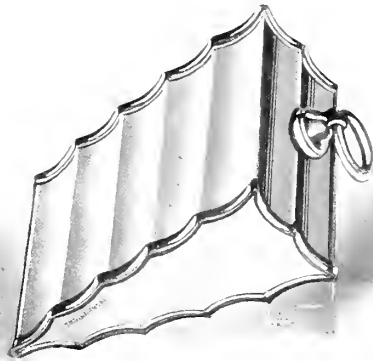

Venison Dish Wedge, by T. Law & Co.
Date 1796. Mr. B. B. Harrison, Sevenoaks.

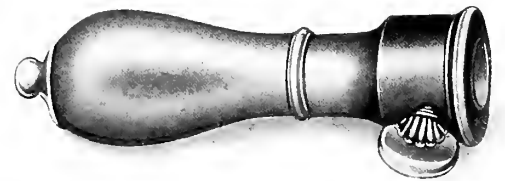

Leg of Mutton Holder, 5 1/4 in. long, by Ashforth, Ellis & Co.
Date 1808. Butt & Co., Chester.



Wine Strainer, by T. & J. Creswick.
Date 1812. Dr. G. Porter, Surbiton.



Wine Strainer, by G. Eadon & Co.
Date 1803. Robinson & Co., Shrewsbury.



Wine Strainer, by Watson & Bradbury.
Date 1816. Author.



Knitting Sheath or Bodkin Holder.
Date 1770. Withers, Leicester.



Vessel used for mixing drinks. A small funnel is fixed inside the lid, down which the liquid is poured. The top pulls off for cleaning purposes, and there is a small outlet for pouring, to which is attached a cork with chain. The vessel is arranged so that the contents can be shaken up before being poured out.
Mr B. B Harrison, Sevenoaks.

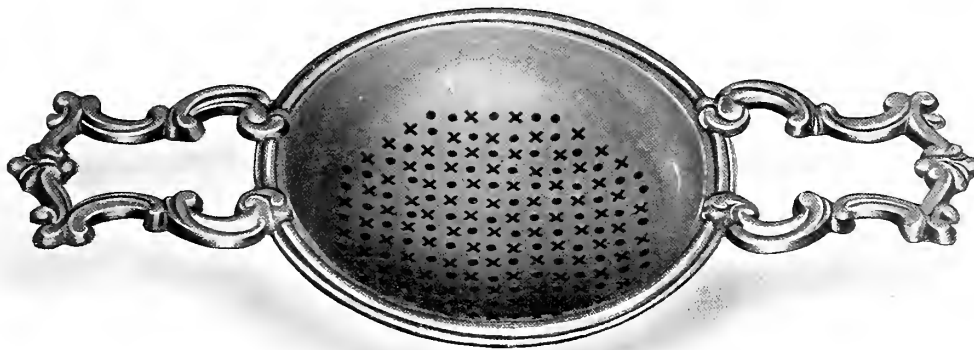

Lemon Strainer, $7\frac{3}{4}$ in. long, with double handles.
Mr. J. W. Usher, Lincoln.



Percolator or Strainer, $5\frac{1}{4}$ in. across top, made to fit on the top of either a saucepan, tankard, or other vessel.
Date 1785. Norris, Cirencester.



Combined Inkstand, Sand Sprinkler,
and Candlestick, $6\frac{1}{2}$ in. high, by
J. Winter & Co.

Date 1778. Chapple & Mantell,
London.



Separate sections of above.



Old Sheffield Plate Coach Lamp, 30 in. high \times 9 in. across face. This lamp is fixed in the entrance hall at Knole Park, Sevenoaks, and is fitted up with electric light, as a hall lamp. It has silver filled facings and fused plated foundation. The coronet on top and terminal are screwed on separately and are of brass. These fittings have evidently been electro-plated, perhaps originally they were gilt, and have been plated in recent times. The lamp was in use on the coach owned by the Duke of Dorset. The late Lord Sackville remembered, when a boy, travelling to London in the coach to which the lamp was attached.

Date 1816.

Lord Sackville,
Sevenoaks.

Concerning coins illustrated below Mr. J. G. Nairne of the Bank of England writes :—" At the beginning of the last century, when silver was very scarce in this country, a large number of Spanish dollars were authorised to be circulated, marked with an impression of the king's head stamped on the neck of the Spanish monarch. This arrangement, however, not proving a success, the dollars were overstruck with the design shown on obverse of silver dollar. These dollars, which were extensively imitated by forgers, ceased to be current in 1817." The forgery illustrated is produced from a finely executed die. The metal (plated on both sides) is $\frac{3}{32}$ of an inch thick. The only weak part of construction is the outer edge of dollar, from which it will be noticed the silver has peeled off in use. The deception is most complete. The specific gravity and ring of coin only would lead to its detection. The process of manufacture was as follows :—A circle of silver was cut about the dimensions of the coin, and neatly turned over the edges of a fused plated disc—in a lathe—corresponding in size to the dollar to be reproduced. The article was now put into the collar of the die, and the force of the press was then applied, the blow brought up the impression of the dollar, whilst the concussion fastened the silver to its edge, and at the same time milled it.



Section showing the edge of fused plated dollar.



Obverse of genuine silver dollar.
Date 1804.



Obverse of fused plated dollar, a forgery, made in Birmingham.



Reverse of genuine silver dollar.
Date 1804.



Reverse of fused plated dollar.

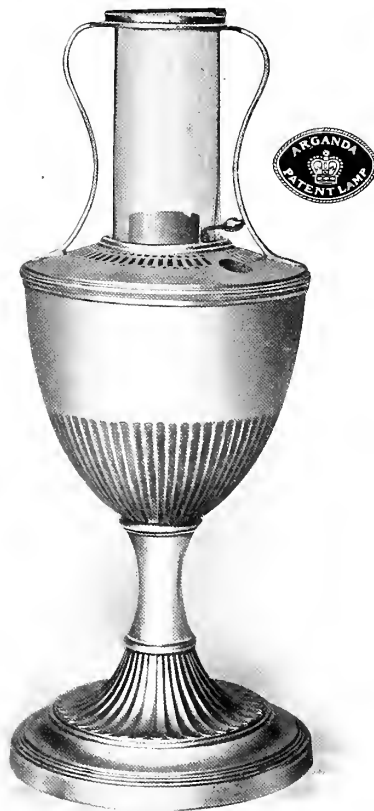

The Arganda lamp (one of a pair) $10\frac{1}{2}$ in. high \times $4\frac{1}{2}$ in. broad. On the top will be seen a little lever, for raising or lowering the wick as desired. This lever was patented. The piercings shown communicated with the chimney and produced a current of air inside and outside the flame. This was the first wick-raising patent, and was taken out by "Ami Argand" in 1784. In 1803 George Penton improved on this patent (he used a button governing a pulley to replace control of the wick by rack and pinion, or wire). This lamp is by M. Boulton & Co., and bears their mark, with name in full, stamped on base.

Date 1784.

Heming & Co., London.

REPRODUCTIONS OF ILLUSTRATIONS FROM MAKERS' CATALOGUES, ARRANGED
IN CHRONOLOGICAL ORDER.

Articles made in Old Sheffield Plate were for sale in almost every town of any size in Great Britain and Ireland, and a large export business was also carried on. Despite the ravages of time, valuable series of the illustrated catalogues issued by the early silversmiths have been preserved, and these lists of their productions elucidate clearly the progress of the art.

Large as was the number of craftsmen who registered as silversmiths in London, their work was far more individual than in the case of the Sheffield platers, and instances of articles made by different workers in solid silver bearing a striking resemblance to each other are scarce. Only the very well-to-do people in former times could purchase solid silver, neither is it probable that any large or extended export trade was carried on in so expensive a class of wares. Consequently the market was restricted and the greatest quantity of silver was made and purchased in London.

No catalogues appear to have been published earlier than the advent of the Adam period of design, but from about the year 1770 down to the present time the illustrations of plated articles offered for sale have been constant and successive. It is well to bear in mind when examining an old catalogue that the articles therein illustrated were produced both before and after the date of publication. Consequently the particulars given underneath the illustrations on the following pages are in many cases only approximate.

If examined closely, the illustrations reveal successive decadence in design more clearly than could be realised by an inspection of the articles themselves.

A contribution on this subject from the pen of Mr. B. B. Harrison, of Sevenoaks, will be read with interest, as he possesses perhaps the most carefully selected collection of Old Sheffield Plate that the author has so far seen. The information supplied is also the more authoritative on account of Mr. Harrison's long experience in printing and publishing. His firm, established in the year 1748 in St. Martin's Lane, London, is now completing its fourth generation in the same family:—

“ In looking through some of the catalogues of the present day manufacturers of Electro plate, one is struck with the profusion of beautifully executed process blocks, the fine printing, the thick glazed paper and general magnificence of the work. But if the catalogues of the Old Sheffield manufacturers are examined, the efforts of their present day competitors sink into insignificance. Where they now spend fifteen shillings or a sovereign for a block illustrating some article, the Old Sheffield manufacturers spent £15 or £20. No process work was then in

vogue, nothing but the pure and exquisite steel engraving, printed by hand, on hand-made paper—one page of which was of the value of a dozen pages of our present day material.

The cost of a single page of these old catalogues would be from £10 to £20 for engraving, and the printing and paper would cost about 15s. per 100 copies ; so that a catalogue of 100 pages of illustrations cost about £1,500 or £1,600 for the first 100 copies and about 15s. per copy afterwards. What would our present day manufacturers think of this !

In no case among the twenty or more catalogues I have examined does the name of a publisher appear. Evidently they were intended to be submitted to the public by the retailer, consequently the names of the makers of the articles have purposely been omitted. Slight clues of identity are, however, at times forthcoming. In one instance the initials *T & L* (Tudor & Leader) are repeated at the sides of varied illustrations of candlesticks. In another catalogue under a sauce boat is printed *TLC* (Thomas Law & Co.) One catalogue, formerly the property of T. Nicholson (see page 45), has inscribed on it in his own handwriting “Dan Holy & Co.” At the foot of the illustrations is printed *Tho. Harris Sculp.^t* (a well-known Sheffield engraver), and the paper of which it is composed was made by Lepard* in the year 1794. In another catalogue, underneath illustrations of candlesticks that were made by J. Parsons & Co., is printed *D. Martin Sc.^t* an engraver in Norfolk Street, Sheffield. He came from Newcastle probably after 1774, and before 1797 had emigrated to America.

In some of the early catalogues illustrations are found of the exceptionally beautiful die work which was in vogue from 1775 to 1805, and the makers, although possessed of a great number of dies, were necessarily restricted in their work to these dies, the cost debarring them from multiplying them beyond a certain point ; and it is interesting and instructive to note the ingenious way in which the changes were rung on these restricted patterns. For instance a stamping from a snuffer tray die would be worked up also in the form of an inkstand ; feet, bottles and supports having been added to the base. The various parts used in the construction of an Adam candlestick are often to be found intermingled in the production of épergues, fruit dishes, and inkstands, etc., whilst dies used for striking a bead or gadroon mount for a salver would be worked in with medallions, shells or some other decorative ornament when mounting a cake basket or teapot, so that even an expert is confronted with considerable difficulties at times in judging the period of an article, parts of which have been struck from dies which were in existence many years previous to the construction of the whole, and the origin of which is due to manufacturers having rung successive changes on the same dies.

The study of these catalogues is most instructive as to the progress, or rather decadence, of artistic design. In the later ones, 1825 or thereabouts, the florid and heavily silver-mounted wares appear to have so entirely superseded the beautiful early work that the publishers of the catalogues do not think it worth while to include a single illustration of the beautiful designs and shapes contained in their earlier issues. In these later days economy also was being studied ; the plates are still almost all steel engravings, but outline work is adopted in place of the detailed work before used. There were exceptions to this, such as in the case of the noted Warwick Vase, which must have been made about 1825, and has a fully finished steel engraving devoted to it.”

The Irish National Museum possess a Sheffield Plate catalogue on the back of which is written by hand in ink *Parsons* and on the fly leaf is a book plate of the D’olier family, who were goldsmiths in *N^o* Dublin in the latter half of the 18th century.†

* This firm is still in existence in London.

† D’olier is listed with other Dublin goldsmiths on page 153.

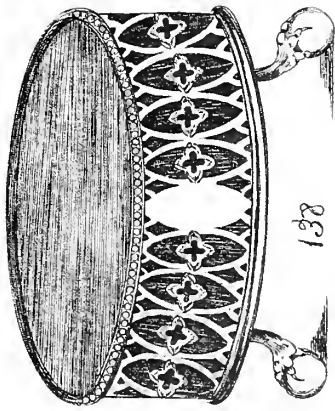

138

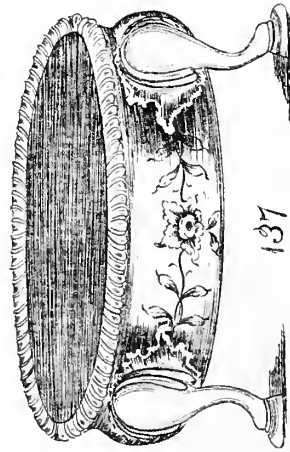

137



136



135



134

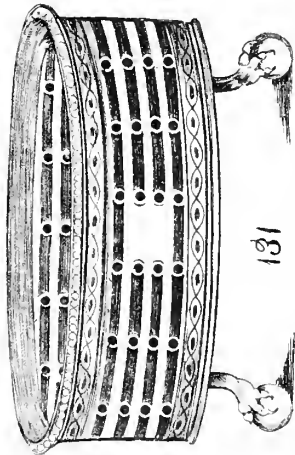

131

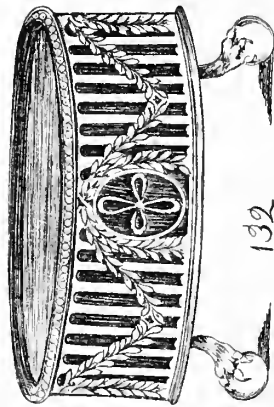

132

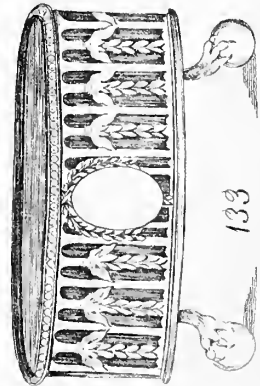

133

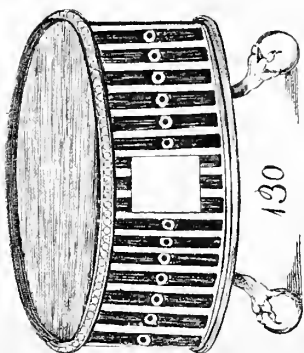

130

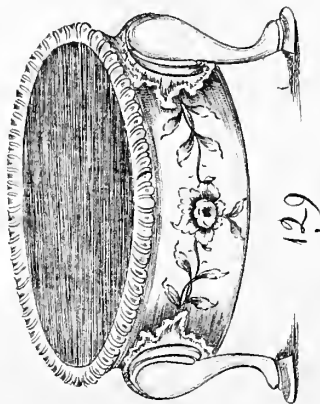

129



128



127



126



Illustrated Designs from Catalogue, embracing the period from 1770 to 1790, showing six varied designs for Coasters, and four varieties of Wine Labels.
The Property of T. Bradbury & Sons.



Illustrated design from Catalogue, about 1770, showing the advent of Adam's influence in design. Pierced Cake Basket, with a light bead mount.

The property of T. Bradbury & Sons.

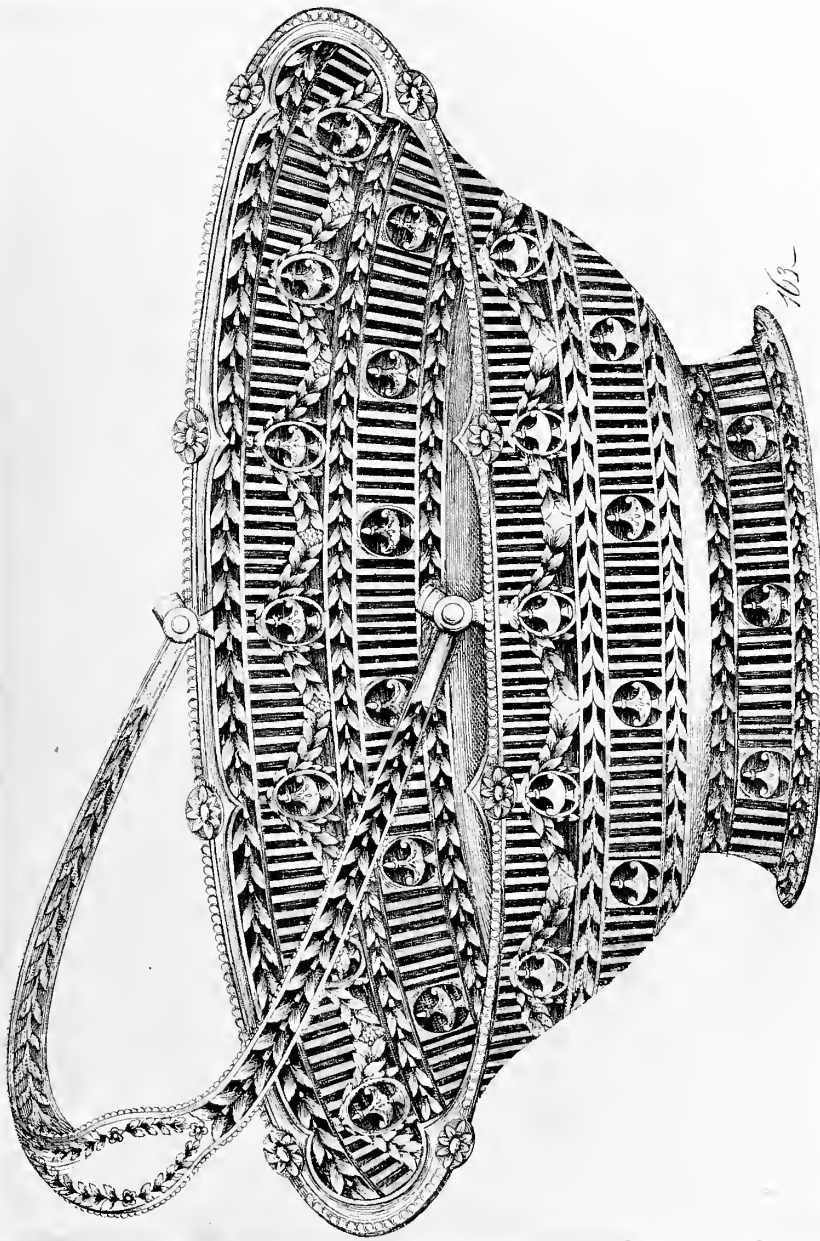

Illustrated Design from Catalogue, about 1775, showing extended decoration in the mounting of a pierced Cake Basket.
The property of T. Bradbury & Sons.

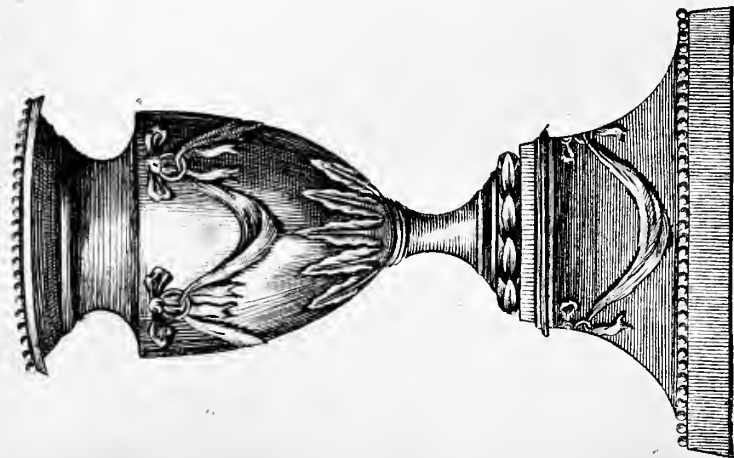

42

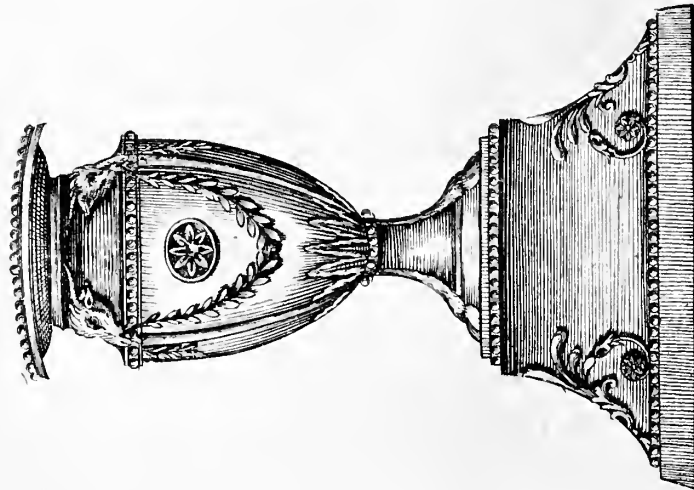

43

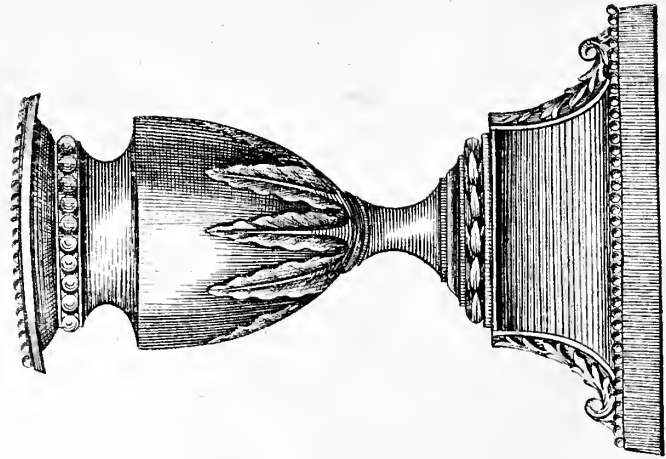

44

Illustrated Designs from Catalogue, showing 3 1/2 in. Candlesticks of the period 1775. The capitals of 12 in. Candlesticks are shown minus the columns, and fixed on to the bases of 6 in. and 7 in. sizes (an illustration of the transposition in the use of dies referred to by Mr. Harrison (see page 397). The Property of T. Bradbury & Sons.

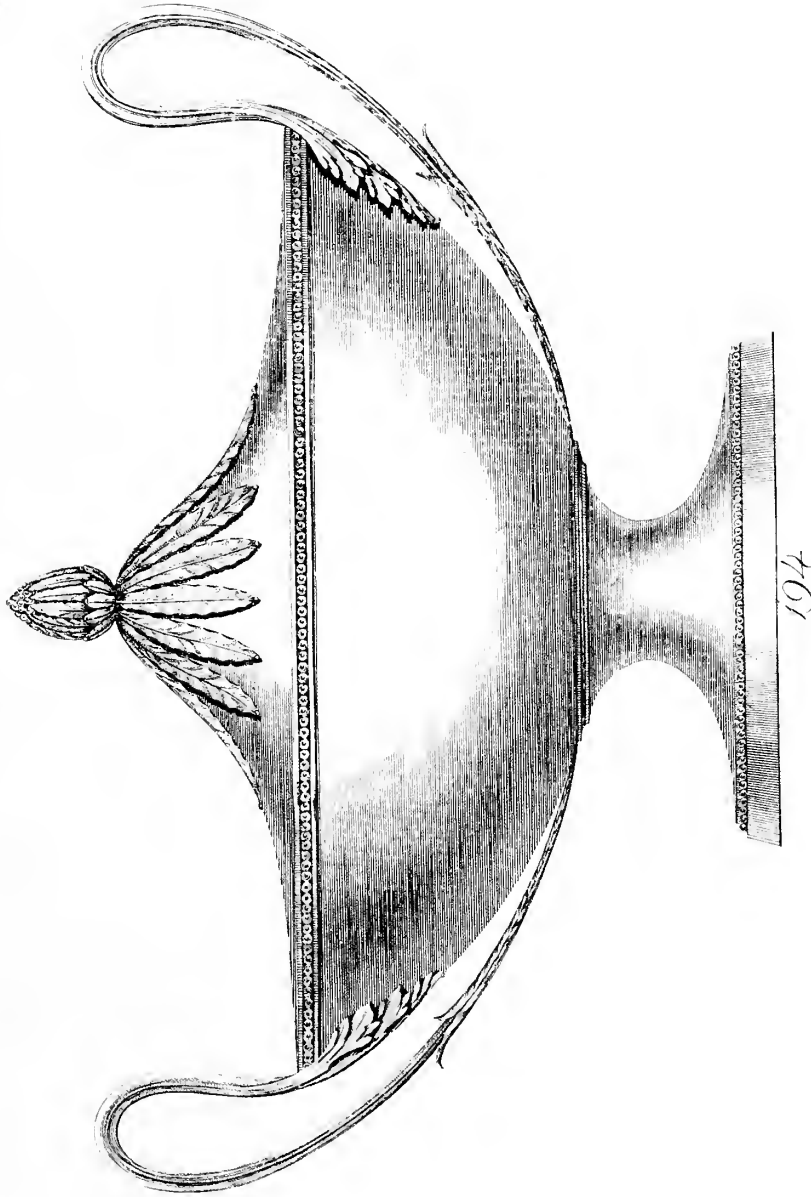

Illustrated Design from Catalogue, about 1777. Sauce Tureen, with plain body, delicate leaf decoration on lid and terminals of handles. This same handle is in use on subsequent illustrations, *vide* Tea Urn page 407, and Cream Jug page 408.

The property of T. Bradbury & Sons.

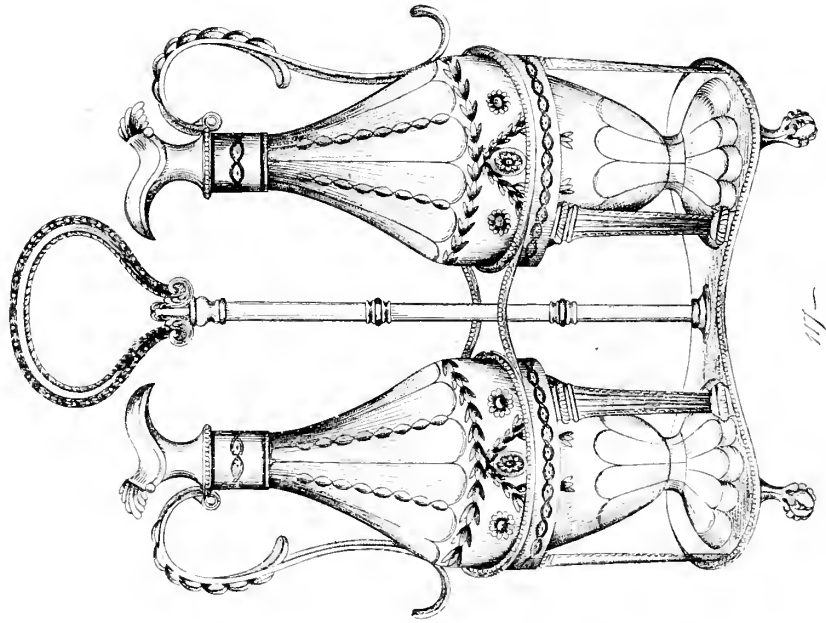

Illustrated Designs from Catalogues, about 1778. The Soy Frames. The property of T. Bradbury & Sons.

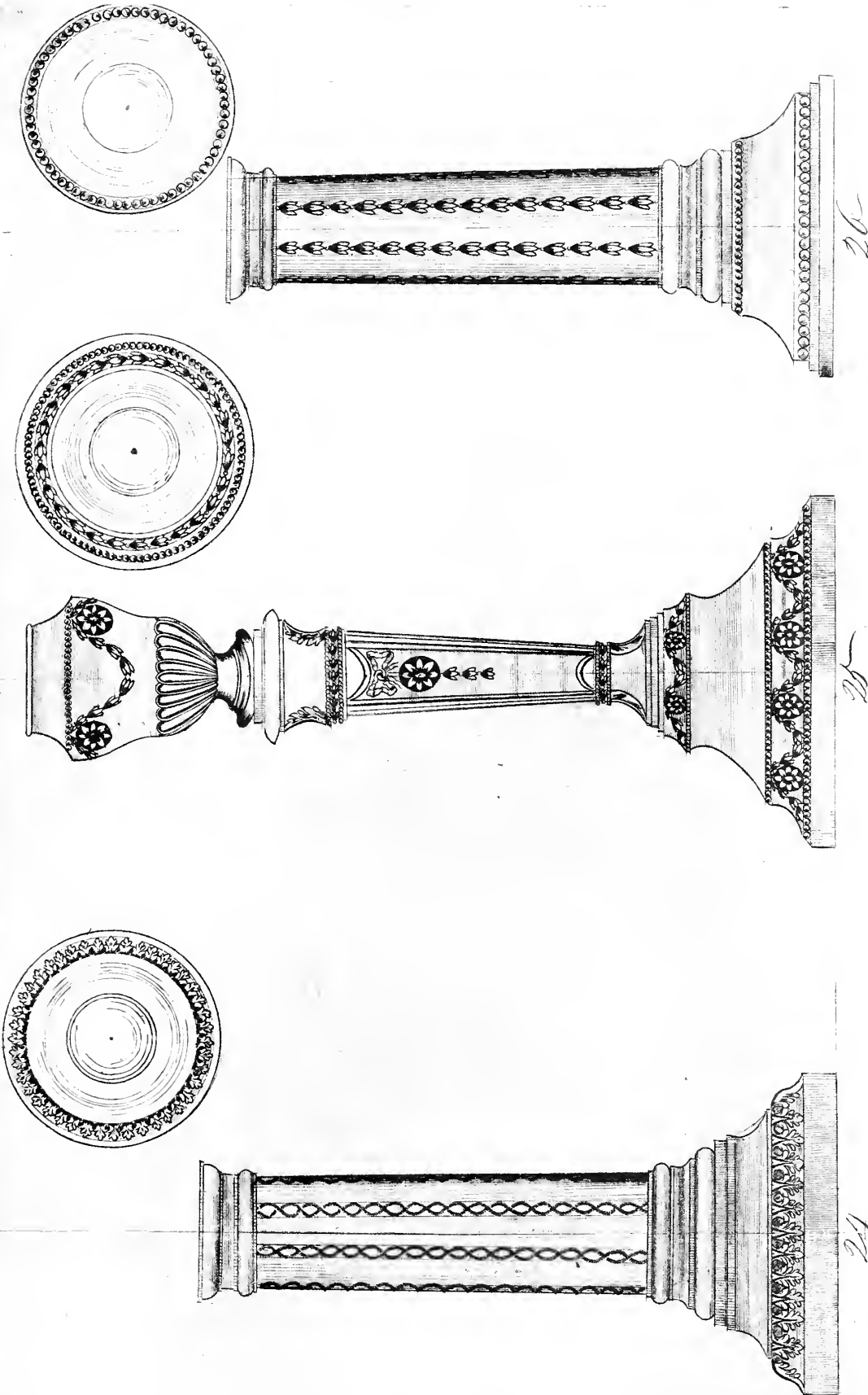

Illustrated Designs from Catalogue, about 1778—1788, showing three varieties of small Candlesticks and Nozzles. The property of T. Bradbury & Sons.

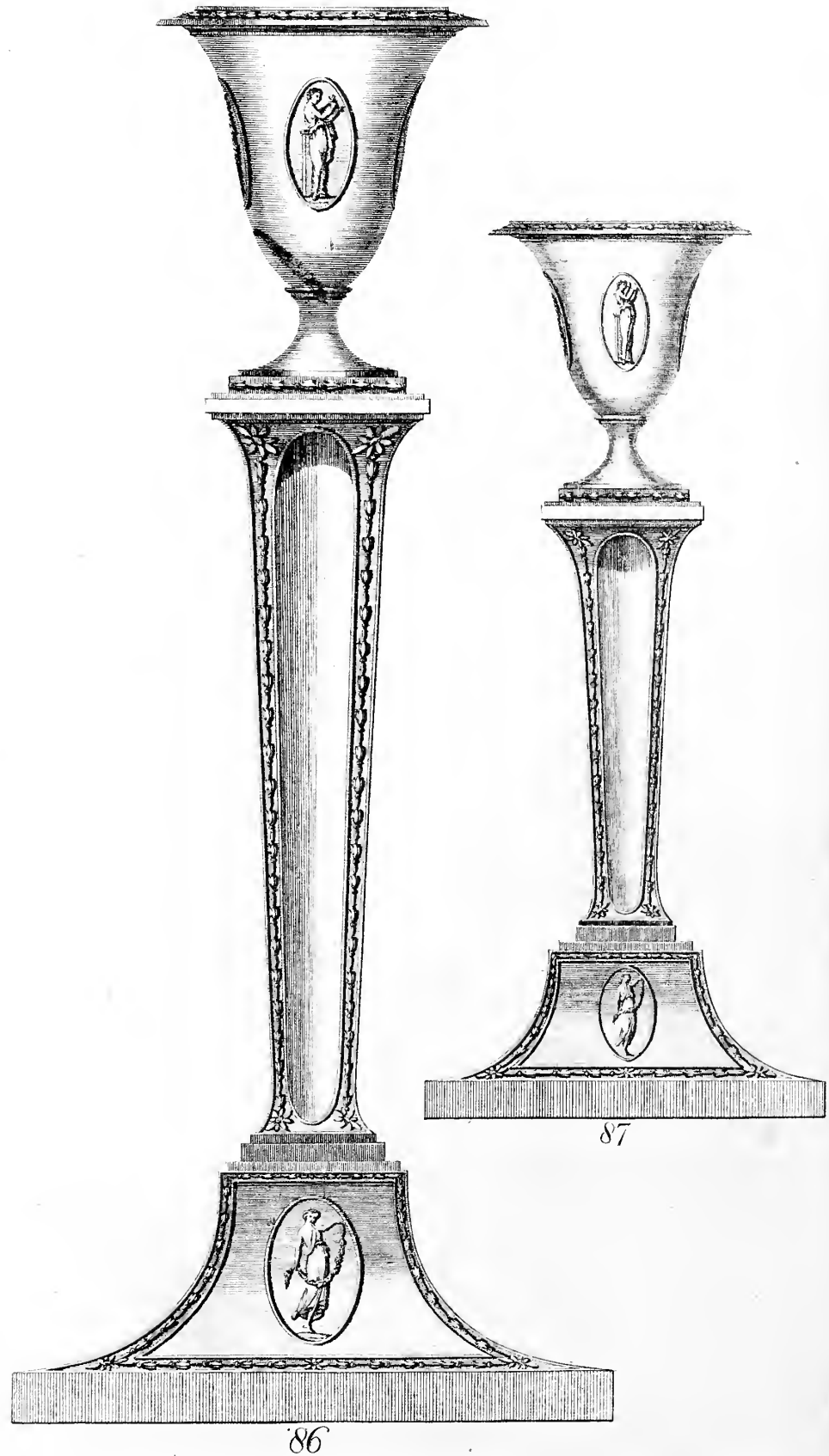

Illustrated Design from Catalogue, about 1780, showing Flaxman's influence in design of a Candlestick, in two sizes, 9 in. and 11½ in. The property of T. Bradbury & Sons.

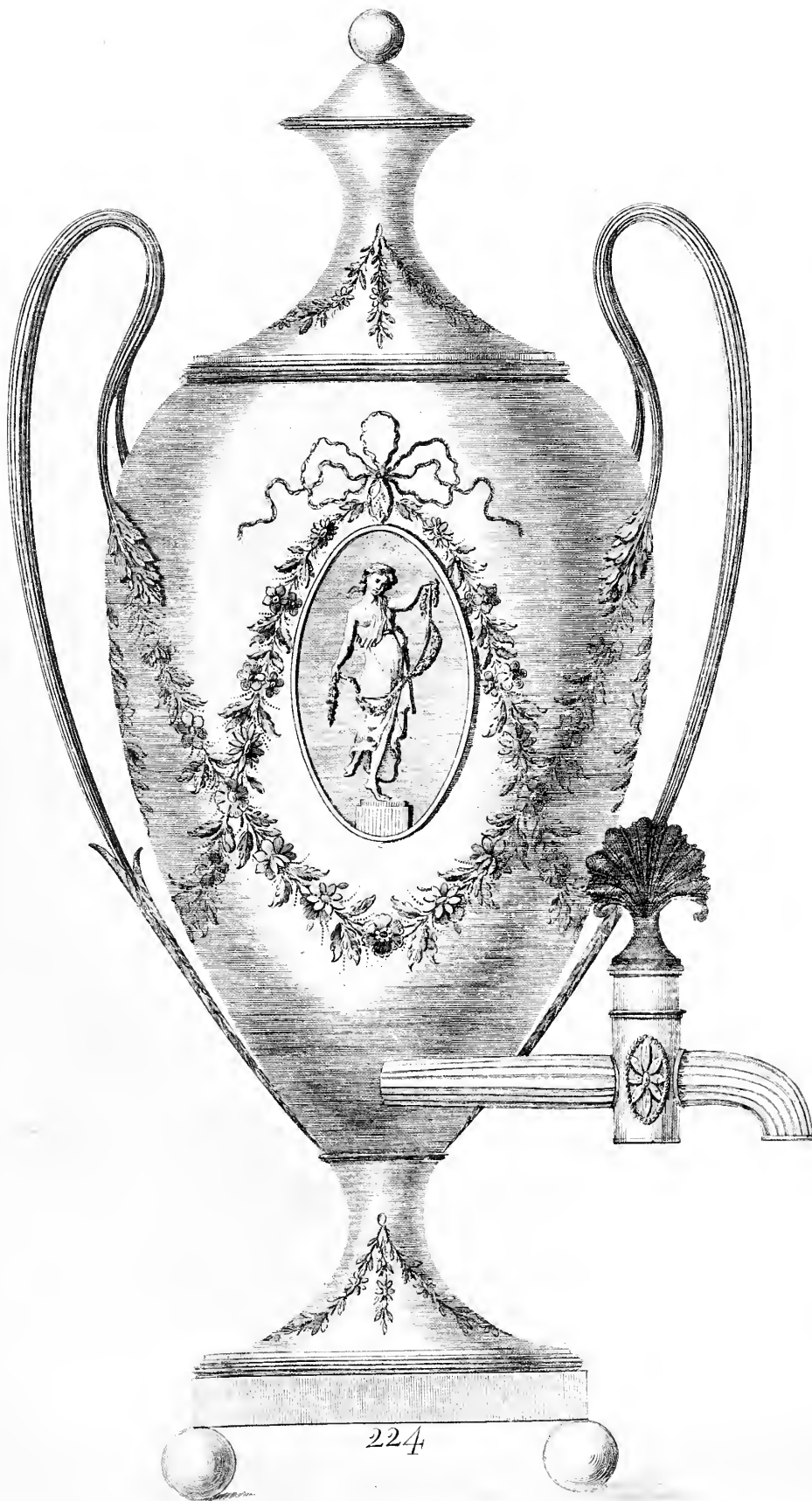

Illustrated Design from Catalogue, about 1782, showing Flaxman's influence in design for a small Tea Urn.
The property of T. Bradbury & Sons.

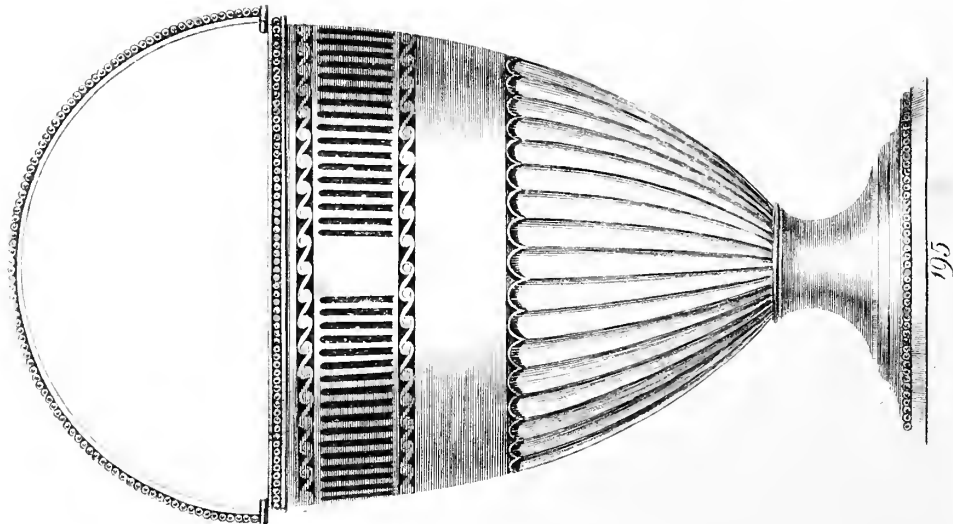
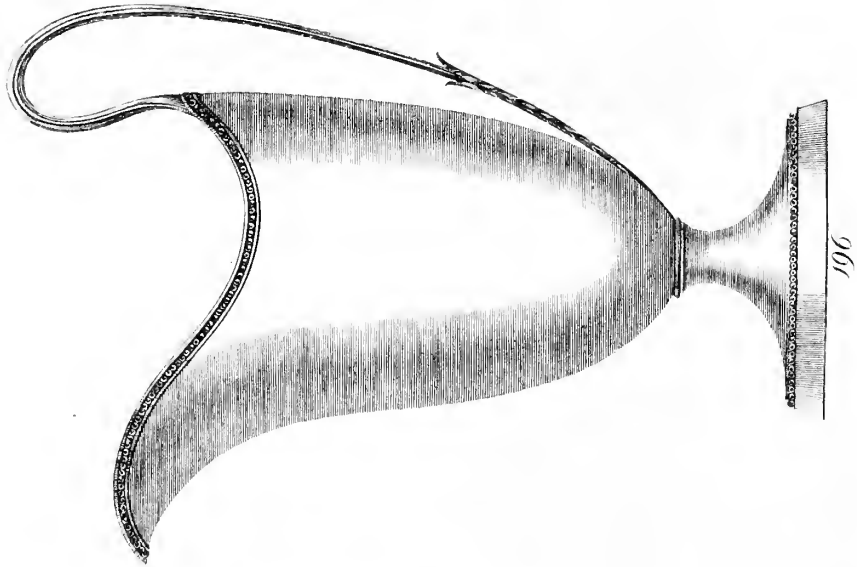
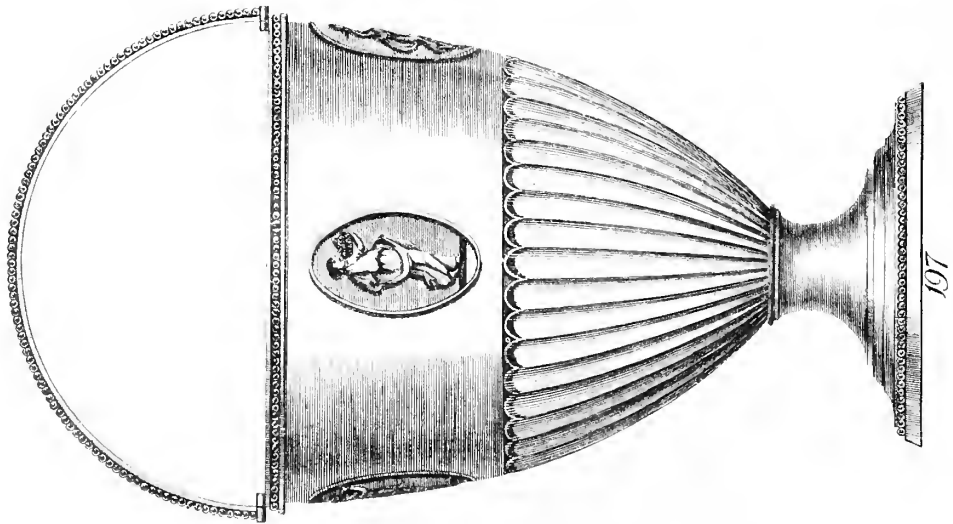

Illustrated Designs from Catalogue, about 1784, showing the helmet cream of that period, and fluting introduced with piercing, and medallions in the construction of "Sugar Basons." The property of T. Bradbury & Sons.

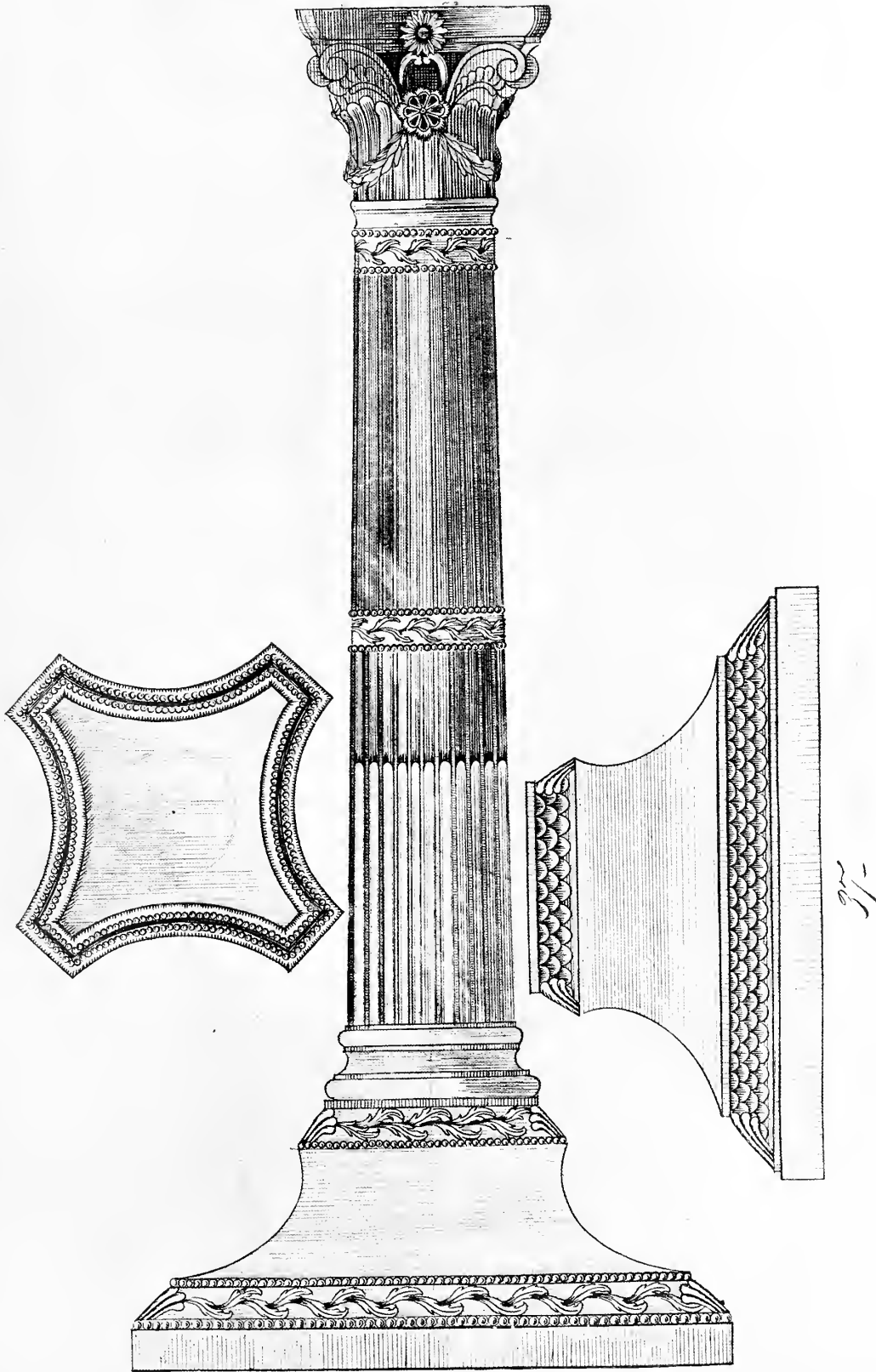

Illustrated Design from Catalogue, about 1786, showing sections of two different bases for $11\frac{1}{2}$ in. Candlestick column, and one section for pan of nozzle. The property of T. Bradbury & Sons.

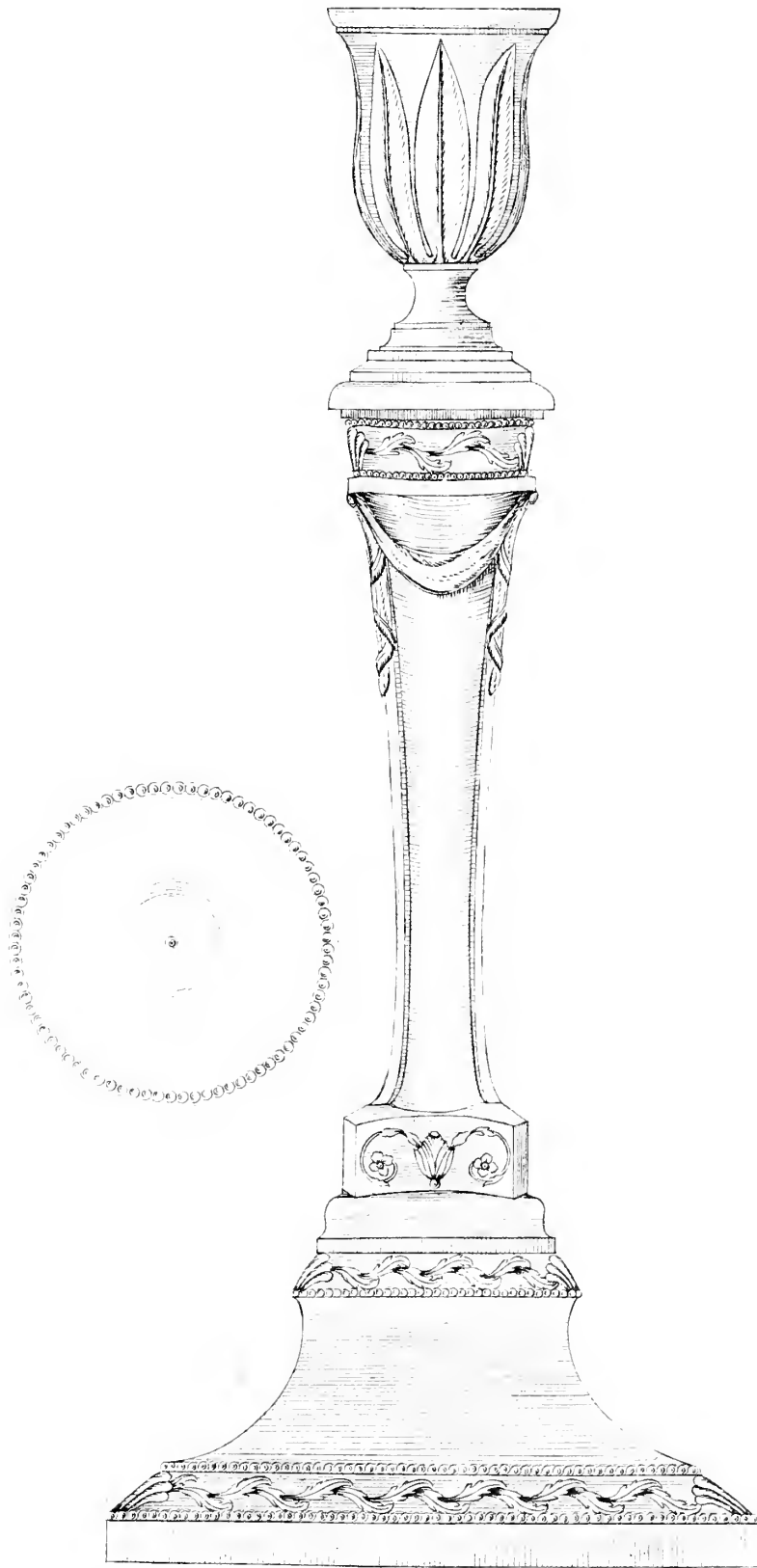

Illustrated Design of 12 in. Candlestick from Catalogue, about 1788, showing section for pan of nozzle,
The property of T. Bradbury & Sons.

1/6 Each

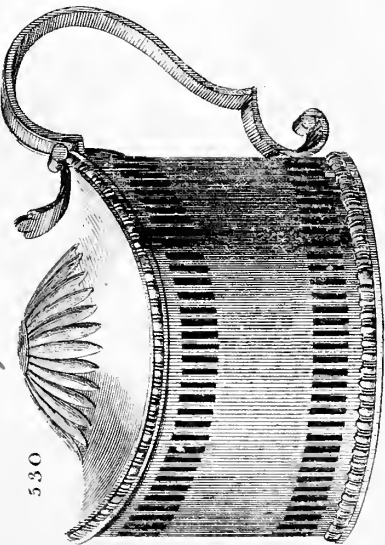

530

Mustard tubs

1/7 Each

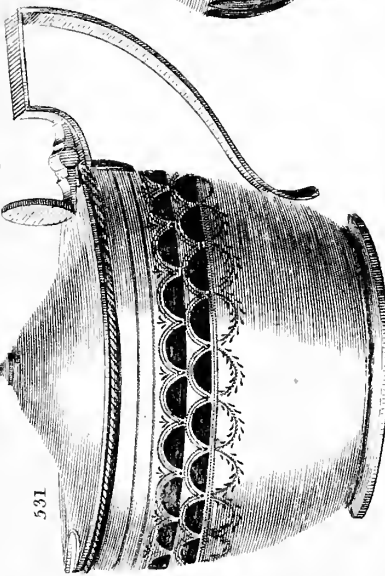

531

1/6 Each

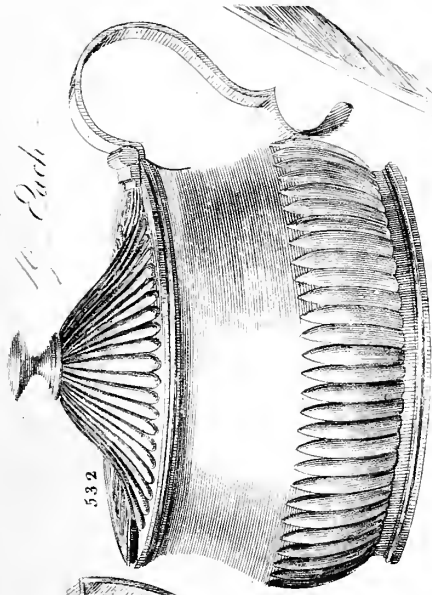

532

1/6 Each 507

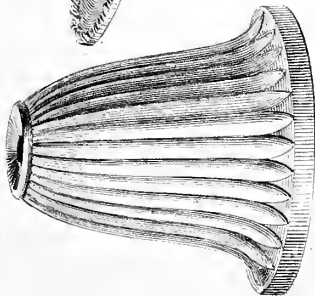

Silver stand

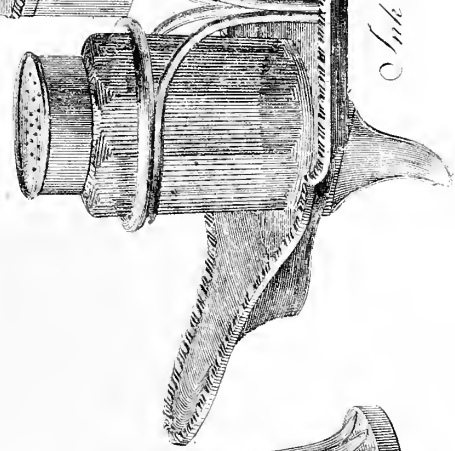

508

1/6 Each

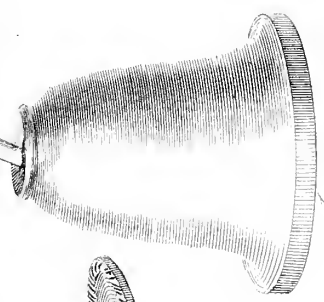

Silver stand

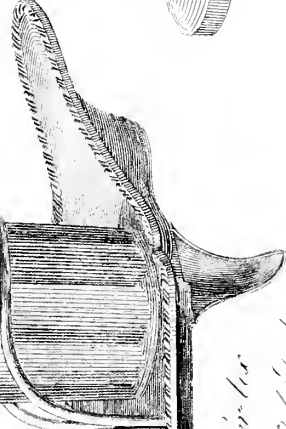
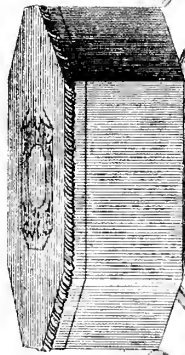

Silver stand 503 with arched top

Silver edges

1/2 Each

Illustrated Designs from Catalogue, about 1789. The first illustrations in catalogues of articles described with "silver edges." The property of T. Bradbury & Sons.

A complete set (of oval shape) for Coffee & Tea, with silver Edges & silver Engraved Shields. The handles of the Sugar basin & Cream jug are also guarded with silver.



Illustrated Design from Catalogue, about 1795. An early example of a combined Coffee Service, with Caddy. The first illustration showing the separately soldered-in shields for engraving.

The property of T. Bradbury & Sons.



Illustrated Design from Catalogue, about 1798. The Coffee Biggin, with Stand and Lamp. The property of T. Bradbury & Sons.

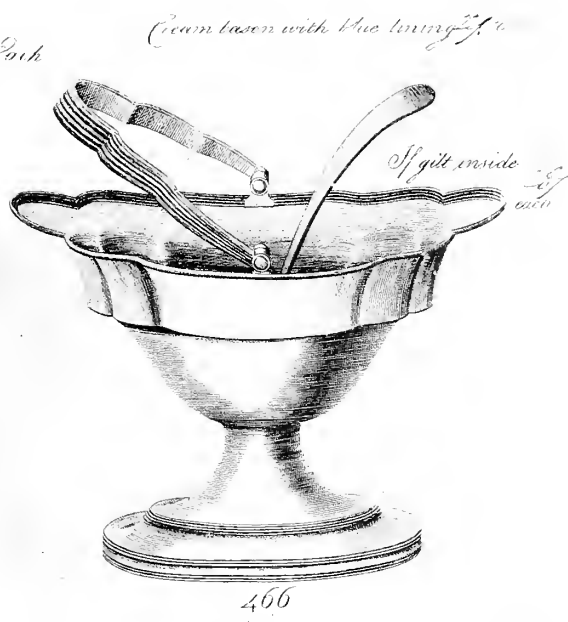
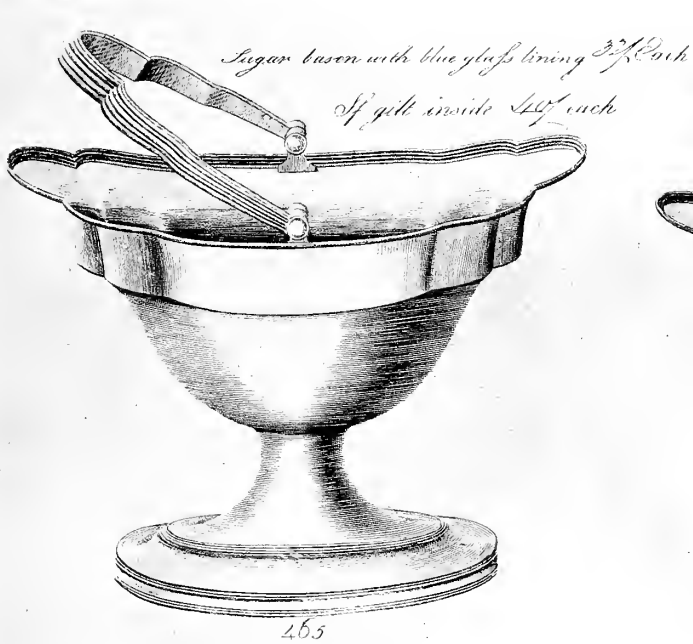

Illustrated Design from Catalogue, about 1798, showing "Cream Bason" (with Ladle) used with the "Sugar Bason" for Dessert. The property of T. Bradbury & Sons.

ROUND

109 Silver-plated D. D. Pair
 Branch to suit with silver-plated
 Silver C and B without silver-plated
 Branch to suit 14 1/2 Each

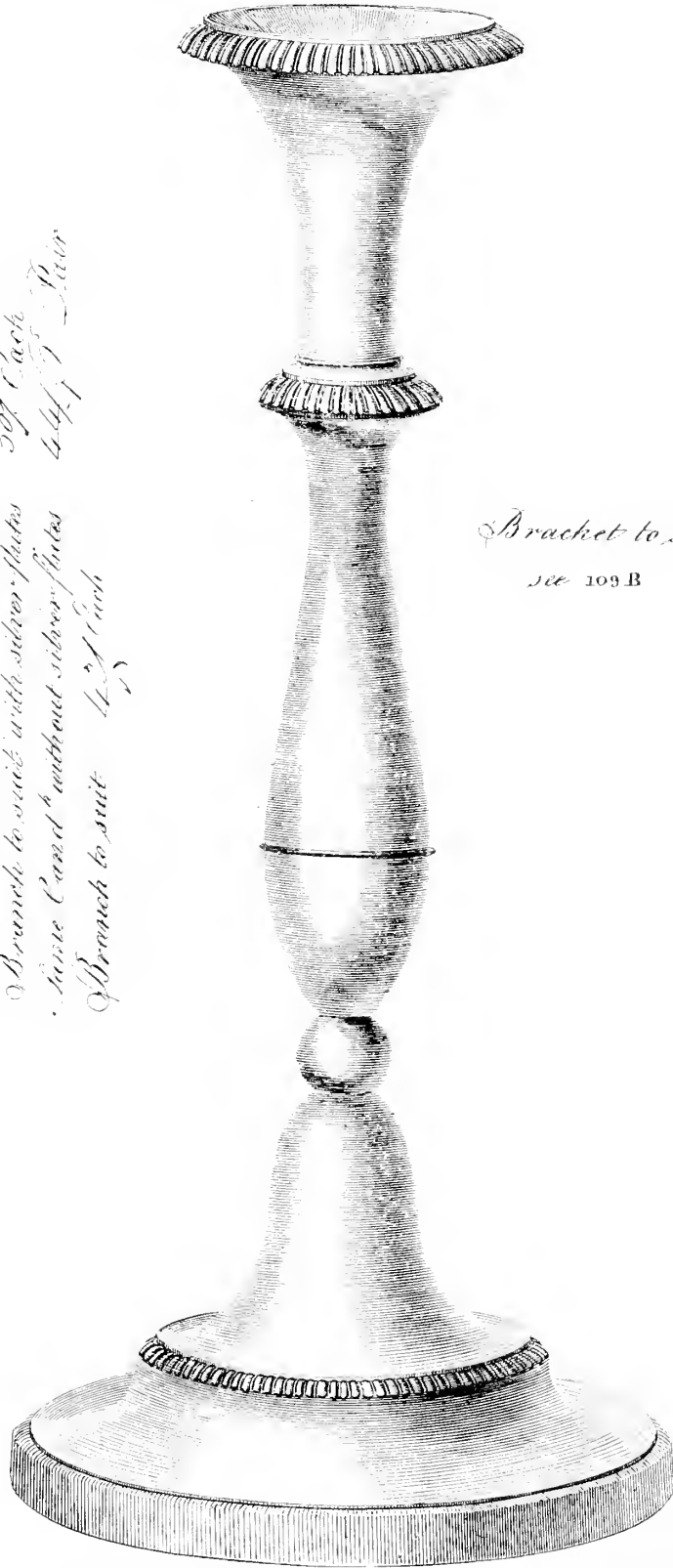

Bracket to suit
 see 103 B

Salt Silver Gad. & Gilt Dish

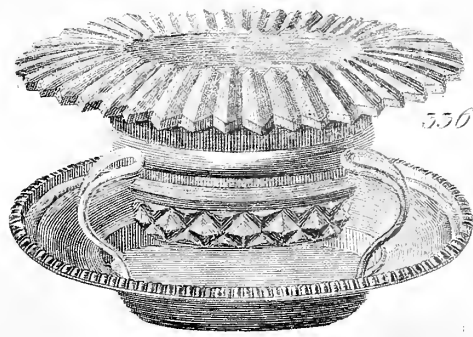
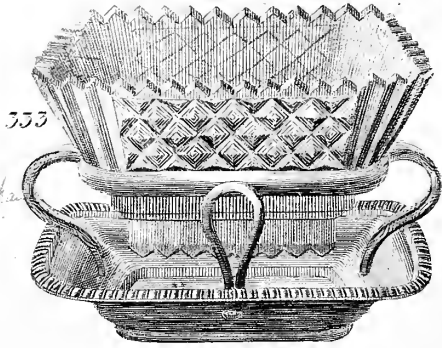

Mustard Silver Gad. & Gilt Dish

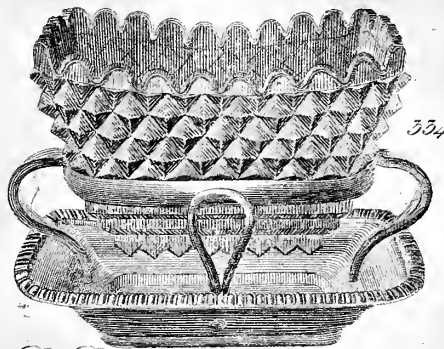
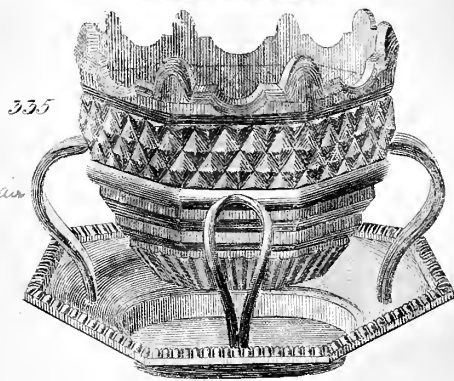
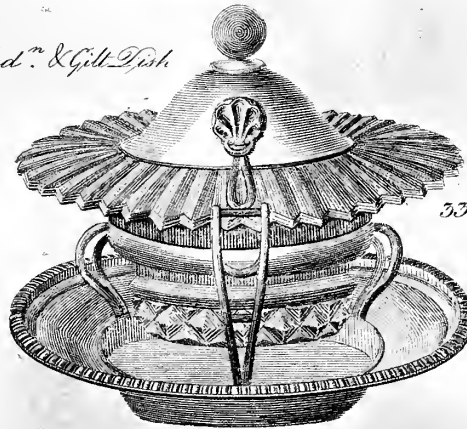
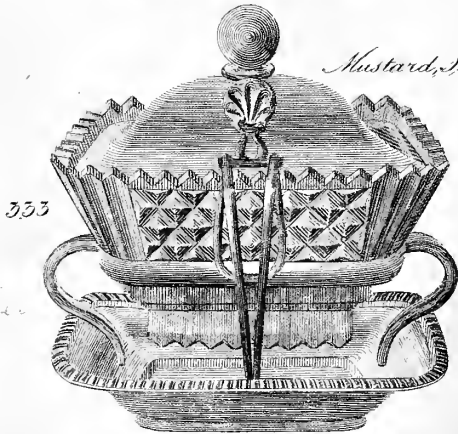

Salt T. P. & D. D.



Mustard T. P. & D. D.

419
TEA EQUIPAGE COMPLETE

*The Large Urn turns upon B to supply
the 2 Smaller Urns with Water the 1 for
Tea the other for Coffee. All the
Urns take off the Frame at A
to use separately if required.
The Part C is for the purpose
of placing a Hot Biscuit.*

*Each Urn 6 Quarts
Cap 1/2 2/3 each.*

Silver Mountings Various Patterns.

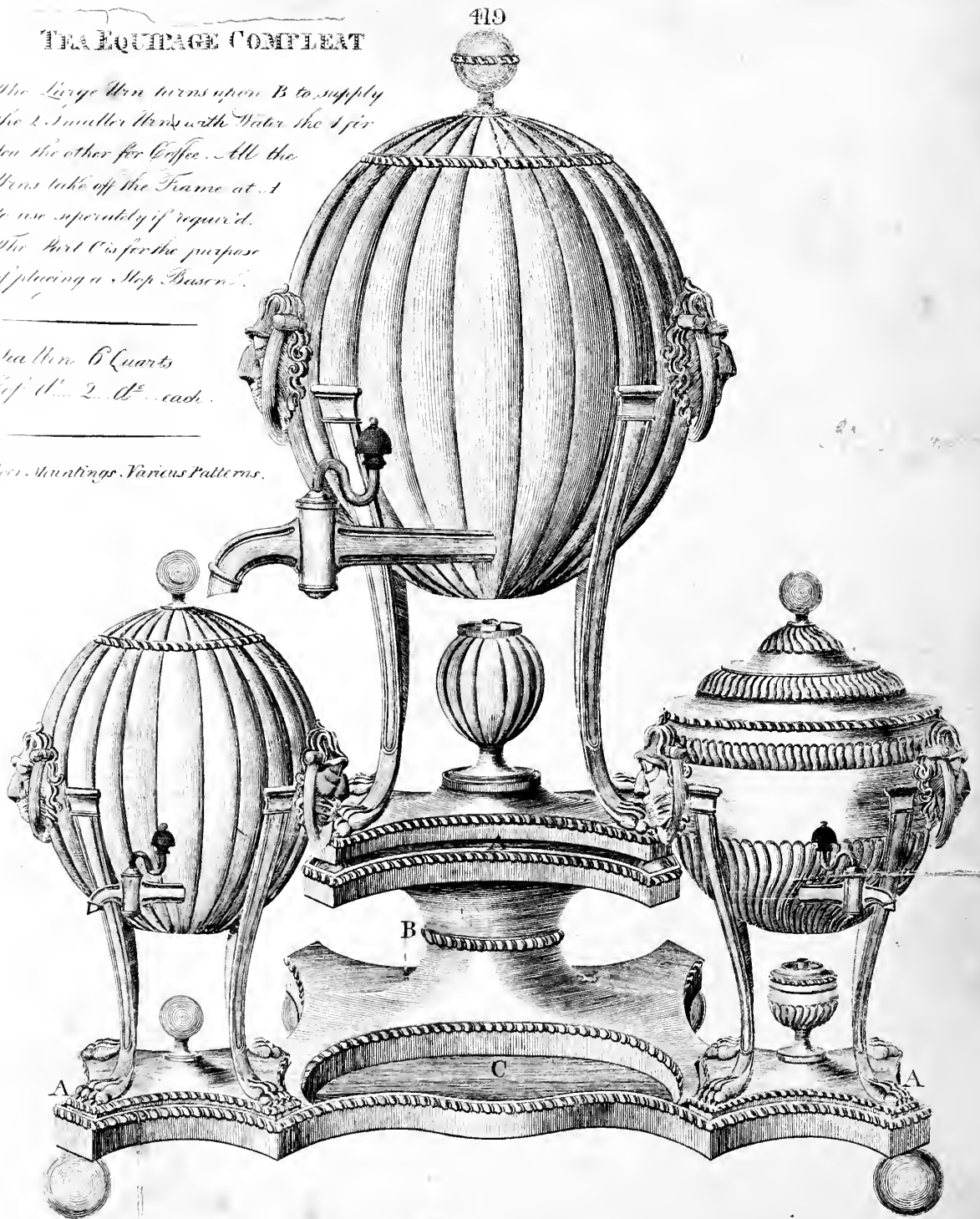

Illustrated Design from Catalogue about 1808. The Tea Machine, showing two varieties of patterns.
The property of T. Bradbury & Sons.

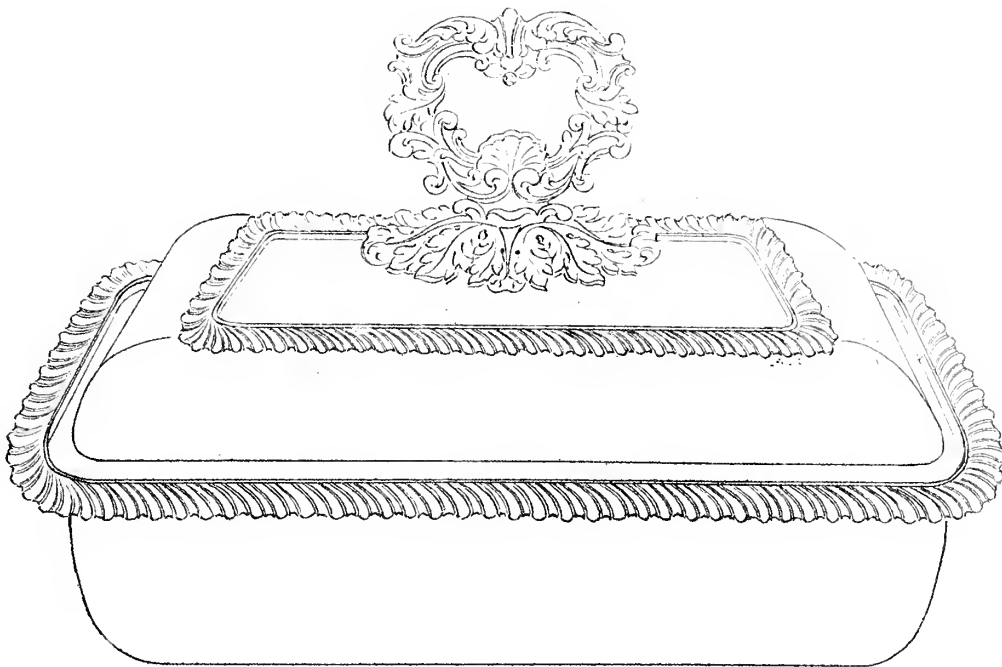

920

Small size 10s/
Middle — — 11s/6
Large size 12s/—

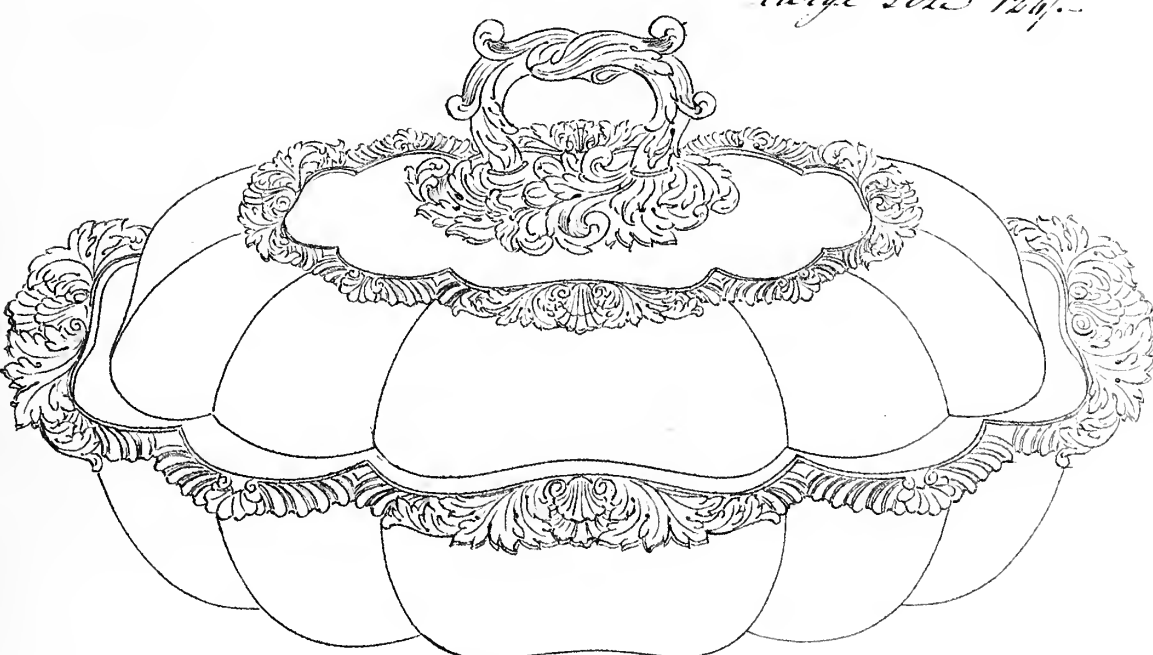

918'a

16s/—

Silver handles, Mountings & Shields

Illustrated Designs from Catalogue of Watson & Bradbury, about 1818, showing the two most popular forms of Entrée Dishes then in use. These have the "rubbed in" Silver Shields.

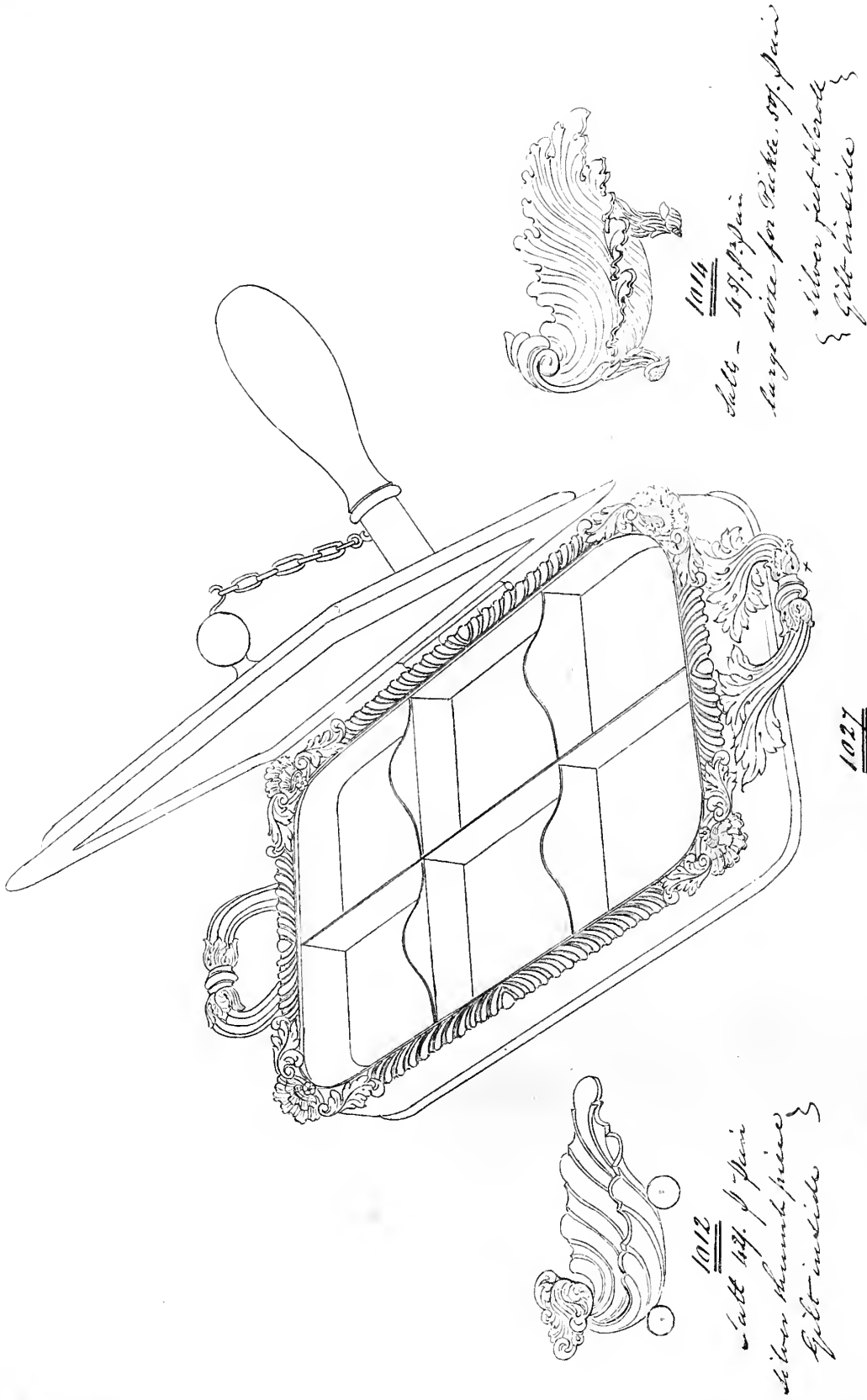

5001



5002

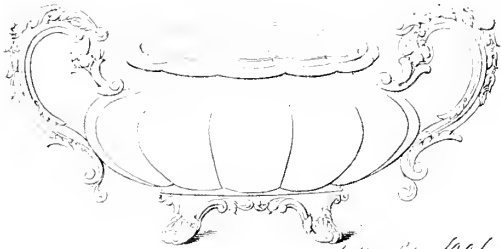

Coffee Pot	100/	Silver Knobs, Feet
Tea Pot	94/6	Mountings & Shield
Sugar Basin	83/	& Plain-plated Handles
Cream Jug	45/	Silver Handles
		Mountings, Feet
		& Shield

Illustrated Design from Catalogue of T. Bradbury & Sons (The Melon pattern Tea Service), about 1830. One of the latest designs before the introduction of German silver.



Illustrated Designs of Sauce Tureens, from Catalogue of T. Bradbury & Sons, about 1835, early transitional from copper to German silver, with filled silver mounts.

No 4478

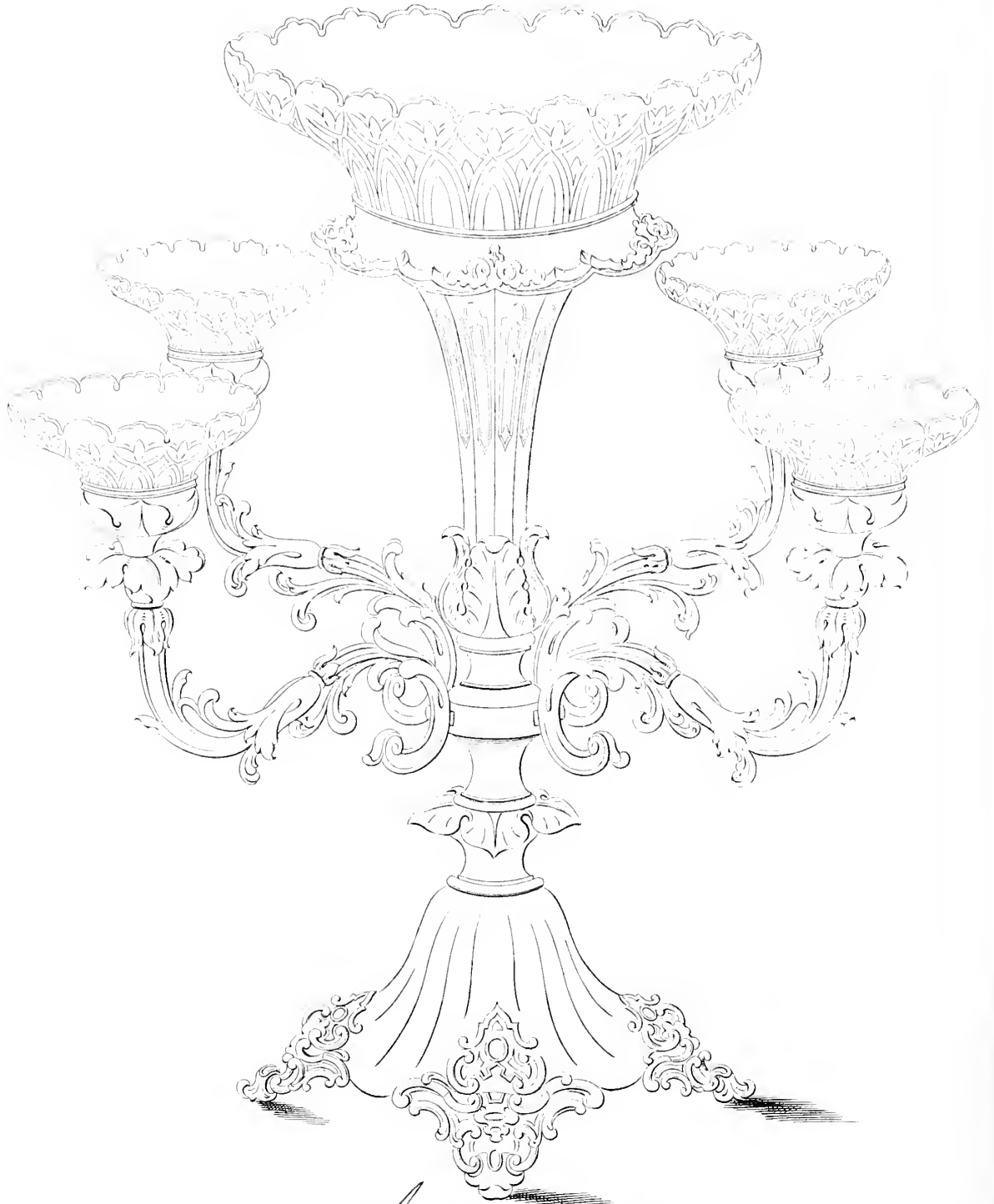

A. B. B.

Illustrated Design of Epergne, from Catalogue of T. Bradbury & Sons, about 1839, early transitional from copper to German silver, with filled silver mounts.

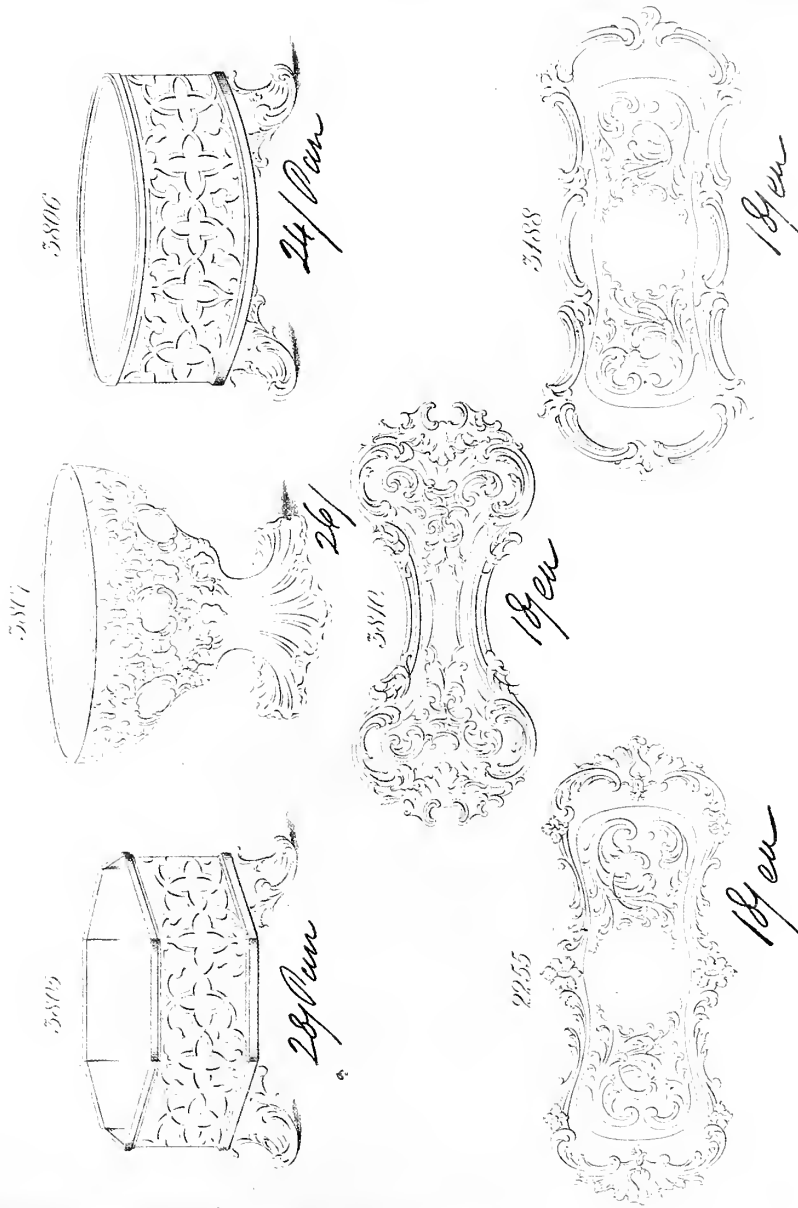

Illustrated Designs of Salt Cellars and Snuffer Trays, from Catalogue of T. Bradbury & Sons, about 1840, early transitional from copper to German silver, with filled silver mounts.

248

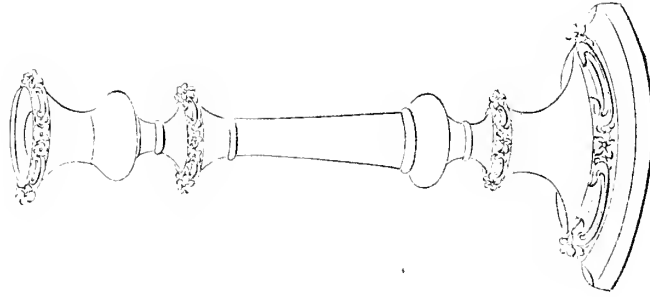

1584

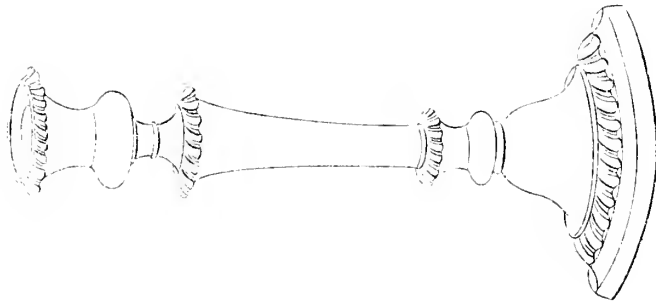

237

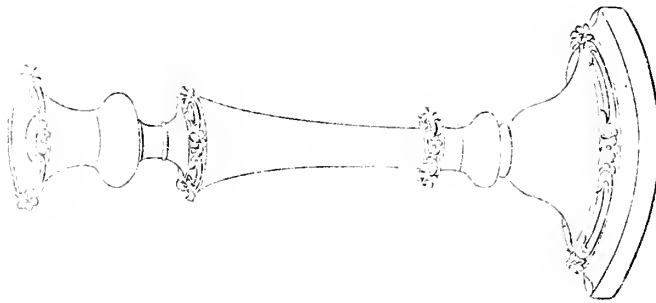

8 7/8 Inch each pattern

9 34/

10 42/

11 45/

12 52/6

Illustrated Designs of Candlesticks, from Catalogue of T. Bradbury & Sons, about 1844, late transitional from copper to German silver, and fused plate to electro plate, with filled silver mounts.

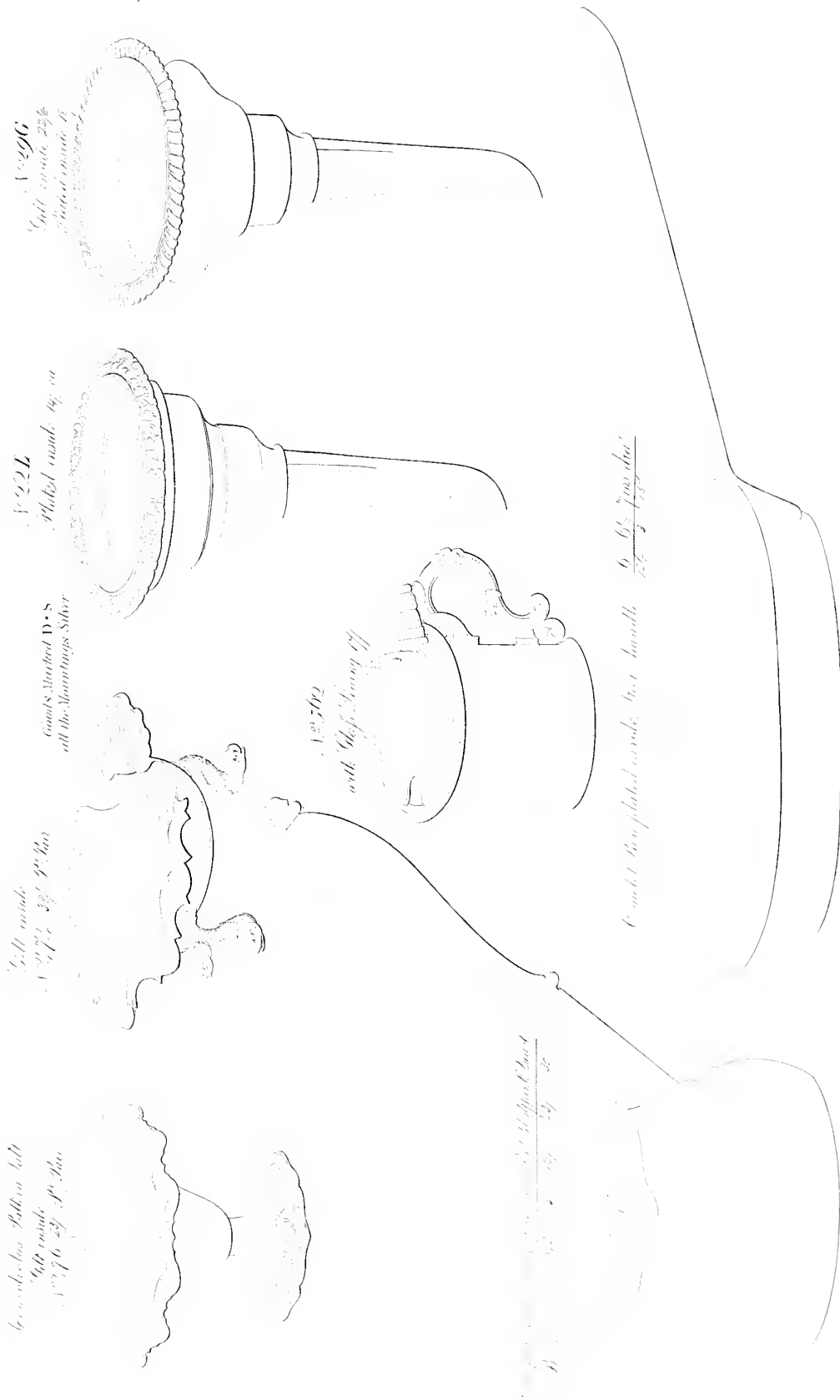

Illustrated Designs of various articles from Catalogue of J. Dixon & Sons, about 1848, late transitional from copper to German silver, and fused plate to electro-plate with filled silver mounts.



Illustrated Design from Catalogue of T. Bradbury & Sons, about 1850. Coffee Service, made entirely from German silver and electro plated. A few only of the mounts—those on the handles—are silver filled.

PART X.

LIST OF MAKERS AND THEIR MARKS.

AN EXPLANATION OF THE MARKS TO BE FOUND ON OLD SHEFFIELD PLATE,
WITH A FEW PARTICULARS CONCERNING THE FIRMS WHO USED THEM.

The marks on Old Sheffield Plate are of far greater interest and importance than the public have hitherto been led to suppose. No doubt the Sheffield plate manufacturers' idea of marking their goods owed its origin to the fact that so many of the earlier makers were cutlers, and therefore had become accustomed to using properly registered marks on their wares. Hence we find that Thomas Law (who was one of the earliest to embark in the new industry) immediately commenced putting marks on his plated articles. He was one of the first to do this. In some instances, too, his name is to be found in full, **TL LAW TL** stamped on various patterns of plated candlesticks, which were probably the first articles to be manufactured by him after he introduced the production of plated wares into his workshops. These candlesticks are, to this day, frequently to be met with by collectors.

The practice above described was general in the trade for twenty years or more, and during this period it is evident that the makers adroitly contrived so to stamp their wares as to give a colourable suggestion of the assay marks on sterling silver—a superficial resemblance, indeed, but sufficient to mislead non-technical purchasers. The usual method appears to have been to put on their own initials, repeated sometimes three or four times and so contrived that they greatly resembled the mark of origin, date letter, lion, and maker's mark, in use on silver goods of the same period. "**TL TH^o LAW TL**" The tankard shown is so well made, and the marks so cleverly punched on both lid and body, that without a close examination it would naturally be supposed that the article was a solid silver one.*



1-quart Sheffield Plated Tankard, with marks on lid and side, much resembling silver assay marks when seen at a distance.

Date 1768-73.

Author.

* For further information concerning Law see pages 19 and 34.

This was the state of things up to 1773. In that year the silversmiths of Sheffield and Birmingham petitioned Parliament for the establishment of Assay Offices in the two towns, on the ground of the cost and delay involved in sending goods for assay to London or Chester. The Goldsmiths' Hall stoutly opposed this application, boldly charging their provincial rivals with fraudulent practices, and a Parliamentary Committee, after taking evidence on both sides, reported as follows to the House of Commons :—

“That the Artificers are now arrived at so great a perfection in plating with Silver the Goods made of base Metal that they very much resemble solid Silver ; and if the Practice which has been introduced, of putting Marks upon them somewhat resembling those used at the assay offices, shall not be restrained, many Frauds and Impositions may be committed upon the Public.”*

The result was that, although the silversmiths of the two towns got their local assay offices, this was at the cost of the silver platers ; for a clause was inserted prohibiting the striking of any letter, or letters, on articles “made of metal, plated or covered with silver, or upon any metal vessel or other thing made to look like silver.” The penalty for infraction of this was a fine of £100.

In 1784, Sheffield obtained another Act. This, reciting the above provisions and setting forth that “doubt, detrimental to the industry, having arisen as to whether a manufacturer of goods, plated with silver, might strike on them his name,” enacted that such wares, “made in Sheffield or within one hundred miles thereof, might bear the surname or partnership name of the maker, together with any mark, figure, or device at the end of the name, such figure not being an assay office device for sterling silver, or in imitation thereof.” And, subject to £100 penalty, such name and device might only be struck after approval and registration by the guardians of the Sheffield Assay Office.

It will thus be seen that a maker of plate need not stamp his goods at all ; but if he did, it must be with a duly registered mark only. And Birmingham, as coming within the hundred miles' limit, was subjected to the Sheffield jurisdiction.

The Birmingham manufacturers naturally objected strongly to these regulations, but all to no purpose ; many attempts were made to evade the Act, but the delinquents were promptly fined by the Sheffield Guardians.

* B. W. Watson's “Old Silver Platers and their Marks.” See also Arnold T. Watson's “Sheffield Assay Office,” pp. 9—13, for the whole controversy.

The following table shows the extent to which the manufacturers of Sheffield and Birmingham availed themselves of the privilege of registration:—

Year.	Sheffield.	Birmingham.	Year.	Sheffield.	Birmingham.
1784	.. 11	.. 5	1810	.. 3	.. 3
1785	.. 7	.. —	1811	.. 3	.. 4
1786	.. 2	.. —	1812	.. 1	.. 6
1787	.. —	.. 1	1813	.. 1	.. 3
1788	.. 1	.. —	1814	.. —	.. 4
1789	.. 1	.. —	1815	.. —	.. 1
1794	.. 1	.. —	1816	.. 1	.. 6
1795	.. 1	.. —	1817	.. —	.. 3
1797	.. 1	.. —	1818	.. —	.. 1
1799	.. 1	.. —	1819	.. —	.. 2
1800	.. 1	.. —	1820	.. —	.. 3
1803	.. 1	.. —	1821	.. 1	.. 3
1804	.. 2	.. —	1822	.. 1	.. 1
1805	.. 1	.. —	1824	.. —	.. 3
1806	.. 1	.. 1	1833	.. 1	.. —
1807	.. 1	.. 18	1835	.. 1	.. —
1808	.. 2	.. 7	1836	.. 2	.. —
1809	.. 2	.. 5			

It will be seen that 16 marks were registered in the first year, after which there was a steady falling off; some years—1790 to 1793—being a complete blank.

In the year 1807 the registrations suddenly jumped to 19—the largest number on record—18 of the proprietors of these marks being resident in Birmingham. Previously to this year, from the commencement of the registrations, only seven marks had been entered from that town during the twenty-three years the Act had been in operation. From this time Birmingham registrations preponderated, and in the year 1824 the Guardians of that town endeavoured to induce Parliament to grant them powers of registration in their own office. But it was of no avail, and shortly after this date the custom appears to have sunk into disuse, as no further registrations from Birmingham took place, whilst only four marks by Sheffield manufacturers were recorded afterwards until the year 1836. After the 20th of June in that year no plate marks were entered at the Sheffield Assay Office, though there is no trace of the Act ever having been repealed. Thus the registration of marks at the Sheffield Assay Office died out gradually. The

total number of registered marks altogether is 134, 80 of them being from Birmingham, 52 from Sheffield (one unidentified), and one from London,* namely that of "Stanley and Thomas Howard, St. Paul's Churchyard" (registered in 1809). This firm would, however, be more than fifty miles outside the prescribed area of 100 miles around Sheffield laid down by the Act of 1784. They were makers of close plated articles.

Since the publication of "Old Sheffield Platers and Their Marks" in 1908, it would be fairly safe to attribute to manufacturers in Sheffield at least 75 % of the old fused plated articles in existence to-day, notwithstanding that the Birmingham manufacturers who registered marks under the 1784 Act considerably outnumbered those of Sheffield.

It is well to explain that the Acts of 1773 and 1784 had very far reaching results, and apparently affected more classes of manufacturers than their framers had foreseen or intended.†



A glance at the descriptions given of these Birmingham platers in the local directories of that city, embracing the period under review, show that those who eventually registered their marks in Sheffield were for the most part a miscellaneous aggregation of harness, button, buckle, cutlery, jewellery, etc., makers and platers, and that only quite an insignificant number could be legitimately described as manufacturers of "Old Sheffield Plate."



The majority of Birmingham manufacturers would, no doubt, previous to the year 1773, be in the habit of putting on the small trifles that they made their initials, marks, or perhaps, names in full, as articles so marked are still to be met with, and these marks in no way resembled the close mimicries that were at that time being adopted on large goods. Thus the clause against such platers as should imitate the silver mark, which the Birmingham silversmiths, in 1773, had to accept as the price of obtaining a local Assay Office, bore hardly on some minor industries of their town. But the grievance was greatly extended when, in 1784, all Birmingham makers of "goods made to look like silver" were subjected to Sheffield's registration jurisdiction. For this reason, therefore, before the year 1807, at which date there appears to have been a general reintroduction of close plating, the number of Birmingham registrations was insignificant.



An instance has been found where G. Ashforth & Co., of Sheffield, stamped on the covers of a pair of plated entrée dishes their registered silver punch  whilst on the base of the warmers was a device resembling a

* B. W. Watson's "Old Silver Platers and their Marks."

† See "Old Silver Platers and Their Marks," pages 2 and 3 of Introduction, sections 2, 3, and 4.



spool  (probably a workman's mark) about the year 1787, though their registered plated mark at that time was . Whether the irregularity ever came under the notice of the Sheffield Guardians cannot be stated. Possibly it may have been due to a mistake on the part of a workman which had escaped notice. Many subsequent instances have been found of irregularities in marking by Sheffield platers; but one occurring so soon after the passing of the Act (1784) is unusual.

It is doubtless a puzzle to collectors of Old Sheffield Plate why so comparatively few specimens bear any marks whatever, and how it was that although nearly every manufacturer registered a mark of some kind under the new Act of 1784, these were seldom used. A probable solution of this question is that the pieces made for sale in the country would usually bear a mark of some sort calculated to enhance their value, but articles intended for the London market, when marked at all, would most likely bear the name of the retailer, and not of the actual maker. As an instance, the mark shown here, from the bottom of an Old  Sheffield beaker, although it bears the impression of a hand, clearly showing it to have been made by a Sheffield manufacturer, bears also, in large letters, the name of Thomas & Co., New Bond Street, a very old firm of London jewellers, and again,  from the bottom of an old Sheffield vegetable dish. The Sheffield manufacturer of his day (in 1784) must have been somewhat disappointed to find that at length, having with much difficulty obtained an Act to allow him to mark his wares, he had to again sink his identity because the London retailers, when any marking was undertaken at all, preferred to see their own names on the goods they sold rather than those of the actual makers. For this reason the practice of marking never became universal.

Again, the three marks illustrated, although of different Sheffield makers, bear the same initials underneath them.    Unless the initials are those of some workman, they must have been struck by the manufacturer, either for some merchant or retailer, albeit all these forms of marking were a distinct contravention of the wording of the Act. It would seem, therefore, that unless the plated marks resembled in their outlines the silver Hall marks, no one considered it his duty to set the law in motion again with respect to these misleading methods of marking.

The size of some of these marks, too, may very likely have been objected to. For instance, the firm of Watson, Fenton & Bradbury* registered their punch at the Sheffield Assay Office on October 7th in the year 1795, but it is seldom that this mark is to be met with. We must conclude that, being a ship in full sail,  it was too big a device to reproduce legibly,—together with the firm's name—on anything but the very largest articles. We also find other well-known manufacturers using their mark very sparingly or omitting their name altogether and stamping the device only. This latter procedure was, however, according to the Act, strictly illegal, and the makers appear to have been pretty evenly divided between those who preferred to run the risks of a prosecution by adopting the stamping of a device only, and those who decided to abjure the marking of their goods altogether sooner than affix their names in full, together with the device, thereby completely spoiling the appearance of the articles when finished.

Then again the chief object of a purchaser would be to obtain goods that bore the greatest resemblance possible to solid silver. Any articles therefore that displayed obtrusive looking marks would consequently be avoided by him.

The most persistent markers of their wares were Matthew Boulton & Co.,† of Birmingham, who registered the sun  and Roberts, Cadman & Co.,‡ of Sheffield, whose mark was a bell.  These two firms seem to have used their marks on plated articles with  great consistency, as also at the present time do the latter firm's successors, Messrs. W. & G. Sissons, who with Messrs. Roberts & Belk§ (who mark a lamp), and Messrs. J. Dixon & Sons (a trumpet with banner), are to-day among the few Sheffield firms using trade marks on modern electro goods to any great extent.

Although Matthew Boulton & Co.'s mark is so frequently met with in England (for some unexplained reason being generally found struck in duplicate) and registered as far back as the year 1784, it is exceptional to find it on articles manufactured late in the 18th century. A quantity of articles bearing this mark, and ornamented particularly with gadroon and shell borders, will readily be found, but they are of subsequent date—from 1805 onwards. Their workmanship is exquisite. They comprise snuffer trays, round salvers, coasters, tea trays, coffee biggins, candelabra, and a whole host of other general table ware. No collector need be long without

* Further information concerning this firm is given on page 37.

† For further information concerning this firm see page 47.

‡ For further information concerning this firm see page 38.

§ In the latter days of the fused plated industry this firm were in existence under the name of William Briggs, about 1823, later of Roberts & Slater, and to-day as described above, but they never registered a mark for plated goods at the Sheffield Assay Office.

specimens of Boulton's latter day productions, as at the date of writing they are extremely common. Being made by the best class of workmen, they have suffered but little during the century's hard wear to which they have been subjected.

Next to Boulton's mark, in England, "the bell" (referred to previously) used by Samuel Roberts & Cadman will be most noticeable; but here again, although registered in the year 1785, it is not very generally to be found marked on articles that were made by them until 25 years subsequently. The *épergne* illustrated on page 292 (having the bell marked on its various parts nine times) is an exception. Probably the earlier pieces bearing this mark have, by constant use, been destroyed. Many of the early goods made by Roberts & Cadman were of an extremely light and delicate description, and of a character of which the *épergne* is an apt illustration. Patent folding toast racks, telescopic candlesticks, innumerable combinations of egg frames, plain kettles and teapots, trays, and salvers with reed and floral decoration, however, are still plentiful, bearing the firm's registered punch.

Richard Morton & Co., one of the earliest firms of silversmiths and platers, registered the mark, a cock,  in 1785. Mortons were extensive manufacturers of all classes of goods in Sheffield Plate. In the year 1780 the name of the firm was changed to Morton, Warris & Co., but the ramifications of the subsequent Morton partnerships (and the use of this mark) have not been satisfactorily elucidated. Articles in which they specialised were pierced salt and mustard pots, wirework baskets, large jugs and snuffer trays with figured subjects thereon, tea urns of a classical style, and candlesticks in keeping with them.

 More than passing notice should be taken of the mark, an open hand, as it has now been in constant use for considerably over a century. It was most consistently used, and to-day is very commonly to be found on Old Sheffield plated articles.





Nathaniel Smith first registered the hand as a mark in the year 1784, and it is at this period often met with in conjunction with his name,  In the year 1810 it was re-registered in the same form by "George Smith, Tate, William Nicholson & Hoult"  (thus described in the Directory of 1817), the firm being mentioned as situated in "Arundel Street." And again in the 1828 Directory it is described as Smith, Tate, Hoult & Tate, of "16, Arundel Street." Now this firm was presumably bought up or taken over by John Watson & Son, of Barker Pool, between the years 1828 and 1837. We find this latter firm described as silver and

plate manufacturers of "16, Arundel Street," in the Directory for the year 1837, whilst the names of the former firm have disappeared. We are also told that John Watson & Son were using the hand mark at this period, 1828-1837. In the year 1845 this firm's address is given as "51, Arundel Street."* In 1849 they had ceased to exist, the firm, Padley, Parkin & Co., of Watson Walk, having purchased their mark, "the hand," which has been very generally used by them and their successors on electro-plated goods ever since.† The firm of John Watson & Son originated with John Watson, of Furnace Hill, who in 1795 registered a mark for silver goods . He became senior partner in the firm of Watson, Pass & Co., Watson Walk, registering the mark for plate  in 1811. Afterwards he traded with his son as J. Watson & Son, at first in Barker Pool or Fargate, later in Arundel Street, until his death in 1835. John Watson, Junr., discontinued the business about 1849. In 1854 the latter was appointed Assay Master, an office held in succession by his two sons, now by his grandson.



Breakfast Dish, the upper part of silver, made by B. SMITH,
LONDON. It contains a loose silver division to serve for vegetables. The warmer—the lower part—is of Old Sheffield Plate, and bears the "hand" mark. Formerly the property of the late Col. Burnaby (killed in the Soudan).





Date 1828.

Mr. J. Tearoe, Sanderstead.

* The changed No. 51 instead of 16 was probably only a renumbering of the street, and not a change of works.

† This mark is now the property of T. Bradbury and Sons.



The hand mark has been noted previously as occurring on a beaker with the name of Thomas & Co., London. It has also been found on the bases of dish warmers and various other adjuncts of solid silver articles, such as candlestick branches, dish stands, etc., these being made from fused plate, whilst the articles themselves are silver, and made by London silver-smiths, notably Paul Storr in the early 19th century. The initials * also occur frequently, with the London date letters, in one instance as late as the year 1828 (see illustration of dish on previous page).

The various Holy combinations furnish another complication of marks. The firm D. Holy & Co. was established in 1776, in which year Daniel Holy, the son of a button maker, succeeded to part of the premises at the Norfolk Street end of Mulberry Street (then recently built), which from 1774 had been occupied as a silver plate works by John Rowbotham & Co.† Rowbotham's associates included, as was so often the case, several men, as Benjamin and Joseph Withers, engaged elsewhere in the cutlery trade, the active silver-smith partners being, apparently, Rowbotham, William Birks and Roger Wilson. It was probably the death of the latter that caused a curtailment of operations, and Rowbotham himself seems to have been dead in 1781, when his widow, Birks, and Withers separated and set up independently. Among the rooms transferred to Holy were the Bitt Shop, the Burnishing Garret, the Braziers' Shop, the Boil Shop, the Stamp Shop, and so on. In 1784 Holy's firm, then known as Danl. Holy, Wilkinson & Co., registered as their silver plate mark a pipe . There was evidently a dissolution of partnership in 1804, Danl. Holy continuing in Mulberry Street, with one Parker, and on the 3rd October registering a new mark, "Danl. Holy, Parker & Co., with a pine-apple . Robert Frederick Wilkinson and James Drabble went off with four others to Eyre Street, carrying with them the pipe mark which, with the name I. Drabble & Co., was registered January 2nd, 1805 . It will be a useful guide to the collector in fixing the date of an article bearing the first device, to know that it must of necessity have been made between the years 1784-1804, and that articles bearing the second and third devices would be made subsequent to the year 1804. Articles which may be met with marked  are of a later date, circ. 1817-1830, and may signify either Daniel Holy and his son George, or his two sons, George and Daniel. The father died in 1831, and in 1833 the sons had relinquished the silver trade for cutlery and steel making.

* B. Smith, Duke Street, Lincoln's Inn Fields.

† Rowbotham and William Hancock (both entered at the London Assay Office) registered as silversmiths at the Sheffield Assay Office in 1773, and John Rowbotham & Co. in 1774. Although they did not register a mark for plated goods, no doubt they made Sheffield plated ware. Their name punch,  for silver goods, is very frequently to be met with to-day. They are also found registered as silversmiths at the London Goldsmiths' Hall, December 14th, 1768.

Nearly all the goods found stamped with the first mark have soldered-in heavily plated shields (see page 89). In Ireland the pieces found with Holy's mark far outnumber those bearing any other. Ireland was evidently the greatest outlet that this firm had for their goods, and no doubt in that country the mark was well known as being struck on goods made in the most excellent taste; articles bearing this name and device would therefore be more readily purchased by the public.

The Crossed Keys was a mark used by three distinct firms.  Firstly by J. Parsons & Co. (the successors of Winter, Parsons & Hall), in 1784; secondly, but placed in a reversed position, in 1799  by John Green & Co.;* and thirdly in 1836 by Henry Wilkinson & Co., who adopted John Green & Co.'s device of crossed keys.  Presumably H. Wilkinson & Co. were commercially descended from John Winter. They succeeded J. & T. Settle about 1831, who were the successors of J. Green & Co. about 1815; their predecessors were in 1787 J. Parsons & Co.; in 1773 Winter, Parsons & Hall; originally, about 1760, John Winter.

Considerable mystery attaches to the use of the mark  so often met with on Sheffield Plate made about the date of the accession of George IV. Specimens by almost all the well known makers have at times been found bearing this device—probably struck, as with silver, to denote Sheffield origin. The standard of goods on which this mark is found is a high one, possibly, therefore, it may have been used to distinguish them from articles of inferior quality made in Birmingham and abroad that were put on the market about the year 1820. It does not appear to have been realized until recent times that the crown as a device was the exclusive property of the Sheffield Assay Office. At the instigation of the Guardians the stamping by manufacturers of a crown on plated articles has to-day entirely ceased.

It has also been stated that the makers struck this device on goods they supplied to Joseph Rodgers & Sons, of Sheffield, who at one time were large factors of Old Sheffield goods.† Rodgers might perhaps be entitled to use the crown by the grant of a Royal Warrant in 1822. Their own mark  registered in the same year, was struck by them on close plated articles of their own manufacture.







* John Green was one of the five partners in the firm of J. Parsons & Co. up to about 1792. For further information, see page 42.



† In Sheffield Directories as late as the years 1845 and 1849, Joseph Rodgers & Sons are classified as "Dealers" under the heading "silver and plated ware manufacturers," whilst in the same directories they are given as manufacturers of "silver fruit and dessert knives."





2-pint Coffee Pot, probably by
J. Winter & Co.

Date 1768. Green & Hatfield.
Ipswich.





The following marks are occasionally met with on articles made between the years 1765-1773,   in all probability attributable to John Winter. There is no other maker of plated goods of this date whose initials at all correspond with the above. We have it also on S. Roberts' testimony (see page 40) that in 1765 J. Winter, with other partners, began to manufacture plated goods, whilst the production of Candlesticks was reserved for himself alone. I. & I. Waterhouse & Co. stamped the gothic crown with many different initials (doubtless workmen's marks), such as   and other devices  . The pieces on which this crown mark was stamped, however, were usually made before the registration of Waterhouse's mark in the year 1833. The same form of crown has been met with associated with









Creswick's mark, "the cross arrows." Thomasons, of Birmingham, can also be traced as sometimes using the crown as a mark on plated goods early in the 19th  century; also J. Willmore, of Birmingham, on close plated snuffers. 

We find that as far back as the year 1807 a mark, * with an acorn, was registered in Sheffield, for plated goods, by a firm of Birmingham manufacturers. George Waterhouse (father of the late S. S. Waterhouse, of Dublin) registered himself as a silversmith at the Birmingham Assay Office, together with Thomas Waterhouse (presumably his brother), in 1830. We also find in 1793 a firm, Kirkby, Waterhouse & Co., registering as "silversmiths" at the Sheffield Assay Office. The mark, the Fleur-de-lis,  sometimes represented in this form, which is often to be found on large (or, to use a trade term, "important") pieces of Old Sheffield Plate of the late period, was used by I. & I. Waterhouse & Co., being registered in the year 1833. The mark, the Phoenix  was used by Waterhouse & Co., of Portobello Place, Sheffield, and registered in the year 1836. This latter mark is extensively to be met with on wine coolers, tea urns, candelabra, and many other fine articles of plated ware of the later period.

* So far no article has come to light which bears this registered mark, though frequent instances occur in which the acorn associated with the crown has been found on Sheffield Plate made between the years 1820-1830.



John Waterhouse, of the latter firm, was son of Joseph Waterhouse, of I. & I. Waterhouse & Co., marrying a daughter of Dr. Hodgson, of Sheffield, in the year 1822. (Dr. Hodgson was in partnership with John's father, Joseph, and registered his name with Waterhouse, Senr., as Waterhouse, Hodgson & Co., silver manufacturers, at the Sheffield Assay Office in the year 1822.) The late Samuel Waterhouse, of Dublin, always used to speak of John Waterhouse, of Sheffield, as his uncle, evidently showing that there was a close relationship between the Birmingham and Sheffield branches of this family.



The Fleur-de-lis seems also to have been a mark much sought after by the manufacturers, and we find it registered in Sheffield no less than four times. Firstly in 1808 by Aaron Hatfield, of Birmingham ; and again by him in 1810 ; then by Thomas Small, of Birmingham, in 1812 ; and lastly (as mentioned before) in 1833 by I. & I. Waterhouse & Co., of Sheffield .

The mark, a globe and cross, was very common on Old Sheffield Plate, being apparently used contemporaneously by several firms, with but slight variations. In 1786 it was registered by Samuel Roberts & Co. ; a similar device, a full moon and cross, being registered in 1810 by a Birmingham firm of close platers, George Bott Dunn . Blagden, Hodgson & Co., of Sheffield, used this mark  very extensively in the latter days of the industry. Mr. T. A. Scott, of  the firm of Hawksworth, Eyre & Co., their successors, has kindly furnished this impression from one of the old punches which he still possesses, and which corresponds exactly with the marks found to-day on the Old Sheffield plated articles themselves. Walker, Knowles & Co. also marked a very "similar" globe and cross to this on their goods,*  but whether they acquired this mark or not from Blagden, Hodgson & Co. is not very clear, though they were certainly using it in the year 1845 (Blagden, Hodgson & Co. having been absorbed by Hawksworth, Eyre & Co. in the year 1833). The globe and cross mark is mostly to be met with on plain gadroon entrée dishes, plain dish covers and venison dishes, and often conjointly with the initials  and also  (workmen's marks). The initials  stand for John Burdekin, one of the old hands employed by Walker, Knowles & Co., and it is interesting to state that this information was supplied by his son, who is still living, aged 85 (see page 133), he himself having worked for many years with this same firm. The initials  Burdekin states, stand for John Brown, a contemporary workman with his father.

* Neither Blagden, Hodgson & Co. nor Walker, Knowles & Co. ever registered these marks at the Sheffield Assay Office.

Although Blagden, Hodgson & Co. used a mark that was not registered by them as a platers' mark at the Sheffield Assay Office, they twice registered a mark there as silversmiths, viz., in 1798 as Thomas Blagden, and again in the year 1808 as Blagden, Hodgson & Co.*



Particular mention should be made of the mark, the cross arrows, registered by T. & J. Creswick in the year 1811.  It is most often to be met with on the larger articles of plate of the later period. The mark itself is not as a rule displayed in a very conspicuous place. On removing the nozzle from a candlestick, the centre light from a candelabra, or on the cap inside a dish cover, it very frequently meets the eye of the observer. The old plated goods bearing this mark are invariably of excellent workmanship, as is the case with the hand, bell, sun, etc., etc. previously noted. Creswick's mark has also been found on articles in conjunction with unauthorised impressions from other punches   (This mark which seems almost too large for a workman's mark was taken from a candelabra of a very late period.)



Creswick is a name associated with the silver and plated trade of Sheffield from the earliest times until comparatively recently. A Richard Creswick was formerly connected with the writer's firm, being in partnership with Matthew Fenton before the year 1773 (see page 37). The family of Creswick is one of the oldest in Sheffield, being resident in the district for nearly six centuries. T. J. & N. Creswick were continuing the old process of plating as late as 1851, when the excellence of their wares won a prize medal at the great Exhibition (see page 141). But in course of time their valuable dies were dispersed, and the mark  is now used by W. Hutton & Sons, its present owners, on electro plate. J. Love & Co.'s mark is often found on plated tankards made between the years 1785 and 1805. The mark was also very regularly used by this firm when making all kinds of hollow-ware.  Gainsford's elephant's head is a very striking looking mark, often to be found on communion plate, heavily mounted waiters and close plated goods made in the early part of the 19th century. It was registered in the year 1808. 

Robert Gainsford was a member of the firm "A. Goodman & Co." who registered the mark  in the year 1800, Fairbairn being also a partner. But it would appear that in 1808 Gainsford commenced business on his own

* The early partners in the firm of Blagden, Hodgson & Co. were Thomas Blagden, Thomas Hodgson, Samuel Kirkby, Joseph Elliott, and John Woollen—names suggestive in respect to the subsequent combinations described above.

account with T. Nicholson as a partner (see pages 45—47). Alex. Goodman dying early in the following year, the trumpet mark was re-registered by George Fairbairn, with John Wright as his partner.  The former mark is very frequently to be met with on old plate, but the latter one is by no means so common.*

A particularly good class of tankards and measures were manufactured by  sometimes marked with his name in full on the sides of the articles, and at others on the bottom, with initials "S.S.", and in the later days the full address is given as "141, Moor, Sheffield." These tankards are mostly to be found locally (in Sheffield), Smith evidently dealing direct with the taverns, as also did Askew, of Nottingham. The excellent finish of Smith's tankards shows how a manufacturer could excel by confining his attention to one class of goods. His measures have been met with in the south of England and as far north as Preston. Smith's name ceases to be recorded in Sheffield Directories after the year 1856; evidently his firm did not long survive the introduction of the electro-plating process.  (of 15, Arundel Street) is a name also found on plated tankards circa 1833.

A very rare mark is Samuel Kirkby's troy weight,  and the excellence of his workmanship was perhaps unsurpassed by any other Sheffield manufacturer. But we must look upon the Kirkbys more in the light of silversmiths than platers, and although different members of the Kirkby family were registered as silversmiths at the Sheffield Assay Office in the latter part of the 18th century, it was not until the year 1812 that Samuel Kirkby registered a plater's mark, and this was but little used by him. It would be safe to attribute some of the most pleasing articles made in plated wire work that are to be met with to-day to the firm of Samuel Kirkby & Co., as they exactly correspond with many hall-marked silver cake baskets, fruit dishes and other smaller articles to be found stamped with the initials .

Messrs. W. Hutton & Sons may aptly be described as one of the earliest manufacturing firms of close plated articles. The existence of their business, as far as we can trace it to-day in Sheffield and Birmingham, has lasted for considerably over 100 years.

The name of Hutton is an old and distinguished one in the Midlands. Dr. Hutton, of Birmingham, wrote a history of that most interesting town late in the 18th century, which to-day is regarded by the inhabitants as the most authentic they possess of the early history and topography of the neighbourhood.

* J. Dixon & Sons' Trade Mark (registered in 1881) is of a somewhat similar character.

We find that in the year 1807 William Hutton, the great-grandfather of Mr. Herbert Hutton, of the firm William Hutton & Sons, West Street, Sheffield, registered a mark at the Sheffield Assay Office in the year 1807, November 19th, *Hutton* 23. At that time Hutton was a close plater. In the year 1830 or 1831 he sent his son, W. C. Hutton, to Sheffield, with the object, which was successfully accomplished, of starting a close plating industry in Sheffield, whilst the original firm conducted their business in Birmingham until the year 1842. Most probably, therefore, the firm of Hutton would be amongst the first, if not "the" first, to establish a plating factory on an extensive scale for the manufacture of close plated cutlery wares in Sheffield. This mark, "the triangle with two curls or ears," is most frequently to be met with on old close plated dessert knives and forks, nut crackers, skewers, spoons and forks, snuffers, lobster picks, and many other articles of close plated ware in use during the period under review.

The firm appear in the Sheffield Directory for the year 1833, described as follows: "William Carr Hutton, 35, Pinstone Street, plater on steel and manufacturer of dessert and fruit knives, spoons, snuffers, etc., in British plate (a form of the newly invented German silver), 58, Eyre Street."

In the Sheffield Directory for 1833 is the following advertisement:—

W. C. HUTTON, Plater on steel and general manufacturer, in Silver & British Plate,
35½, Pinstone Street, Sheffield.

Plated on steel:—Table and dessert forks; table, dessert and tea spoons; ladles, etc., with or without the improved silver edges and points; dessert knives and forks, and butter knives with or without handles; fish slicers, skewers, knife rests, nut crackers, toast racks, snuffers, spurs, and various other articles.

THE BRITISH PLATE OR IMPROVED GERMAN SILVER

is manufactured into every article enumerated above, as also into patent pencils, pen and pencil cases, &c., the whole of which are wrought and warranted to be solid and serviceable.

SILVER dessert knives and forks, butter knives, pickle forks, fruit knives, sugar scopes, tea shells, pen and pencil cases, patent pencils, guard chains, snuff and scent boxes, eye glasses, thimbles, stiletos, bodkins, scissors, desk scales, etc., etc.

Also plated copper spoons, sugar tongs and crushers, decanter-corks and labels, knife rests, toast racks, etc., etc.

N.B.—Scissors, surgical instruments, or any other articles in steel, iron, brass or copper, may be plated with silver at the above establishment, on the shortest notice.

By the year 1845 W. C. Hutton had moved to 27, High Street, and in addition to the goods enumerated above he advertised the making of German silver nut crackers and Britannia metal spoons. To-day this firm, trading as "William Hutton & Sons Ltd.," has extensive premises in West Street, Sheffield, for the production of all kinds of silver and plated goods.



In the latter period of the industry, and about the date of the introduction of German silver (1830-1840), there was a tendency to revert to the earlier practices of striking on plated articles marks bearing close resemblance to those used on sterling silver. The use of a crown (see page 434), which began about the year 1820, eventually became so common a form of device that manufacturers apparently considered themselves entitled to strike it indiscriminately on plated articles. Why, until the year 1896, no official notice was taken by the Sheffield Assay Office Guardians of this transgression is somewhat of a puzzle. Animals were also at times struck in separate shields closely resembling in their outlines the Lion and with makers' initials attached. The deception—for so it must be described—was most complete. * Such counterfeiting far more closely resembled Hall marking than the crude representations that caused the passing of the first Marks Act of 1773.

The marks reproduced  were taken from an electro-plated German silver chalice purchased in Dublin, most probably made by J. Smith & Sons, of Sheffield, about sixty years ago. Other articles bearing these devices have been met with in England, though for many years past their manufacture has entirely ceased.

WORKMEN'S MARKS AND MANUFACTURERS' NUMBERS.

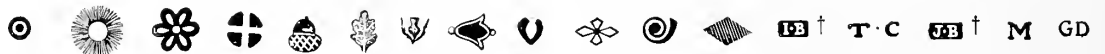
Separate marks struck by workmen on Old Sheffield Plate are not very generally to be found before the year 1785. These marks, initials or small devices, were struck for the purpose of identification. The practice of marking still survives in Sheffield amongst the men who make articles both silver and plated. The following are a few specimens that have been found on Old Sheffield goods, and which it is presumed were used by the workmen.













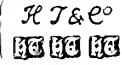



These marks are most frequently found on the bottom of bizzles of candlesticks, as also at times the makers' stock numbers, **1583**, **1716**, **1815**, occasionally associated with their trade mark **1262**  The public sometimes misinterpret these numbers to denote the year in which the article was made, whilst the workmen's marks are constantly mistaken for those used by the manufacturers, the confusion in some cases being due to the fact that these marks were struck in close proximity to the maker's device. On teapots, coffee pots and jugs of a late period, marks are occasionally found indicating their holding capacity.  In this instance, the mark of the makers, Walker, Knowles & Co., is also shown.

* These devices are most frequently found on close plated cutlery. The initials "ps" stand for plated steel.

† See page 436.

APPROXIMATE DATES OF THE MANUFACTURERS' EARLIEST CONNECTION WITH THE FUSED PLATE INDUSTRY PREVIOUS TO 1773.

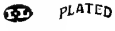
Name of Firm.	Maker's Marks.	Date.	Location.	Trade Description.
Boulsover Thomas...	No Mark Traced.	1743	Sheffield, Norfolk Street	Cutler, Button and Box maker.
Hancock Joseph ...		1755	Sheffield, Union Street-- High Street	Cutler, and maker of Plated Hollow-ware.
Smith Nathaniel ...		* 1756	Sheffield, Waingate ...	Cutler.
Law Thomas ...		1758	Sheffield, Baker's Hill ...	Silver Cutler & makers of Plated Hollow-ware and Candlesticks.
Tudor & Leader ...		1760	Sheffield, Sycamore Works	Silver and Plate manufacturers.
Fenton Matthew & Co		† 1760	Sheffield, Mulberry St....	Do.
Unidentified ...		1760	Sheffield	Plate manufacturers
Unidentified ...		1760	Sheffield	Do.
Unidentified ...		1760	Sheffield	Do.
Hoyland John & Co.		1764	Sheffield, Union Street...	Silver and Plate manufacturers.
Boulton & Fothergill		1764	Birmingham	Do.
Roberts Jacob & Samuel		* 1765	Sheffield, Pond Hill ...	Silver and Plated Cutlery manufacturers.
Winter John & Co.		† 1765	Sheffield	Silver and Plate manufacturers.
Morton Richard ...		1765	Sheffield, Brinsworth Orchard	Do.
Rowbotham J. & Co.		* 1768	Sheffield, Norfolk Street	Do.
Ashforth, Ellis & Co		1770	Sheffield, Holy Croft ...	Cutlers and Plate manufacturers.
Ryland William ...	No Mark Traced.	1770	Birmingham	Plater.
Littlewood J. ...		1772	Sheffield, Westbar Green	Plater and Silversmith.

* Marks used on plated and silver cutlery.

† It is only presumed that these marks were used by this firm.

EXTRACTS FROM LISTS OF MANUFACTURERS FROM "SKETCHLEY'S SHEFFIELD DIRECTORY,"
1774.

NO MARKS LEGALISED ON PLATED ARTICLES, ACCORDING TO THE ACT 1773.

Name of Firm.	No Maker's Marks Used.	Location.	Trade Description.
Bunbury Thomas	Sheffield, Norfolk Lane ...	Silversmith.
Elliott Thomas	Do. John Lane	Silversmith.
Ellis Thomas	Do. Norfolk Street ...	Silver Plater.
Fenton, Creswick & Co.	Do. Mulberry Street ...	Silver & Plated manufacturers.
Greaves Johanadab	Do. Church Lane ...	Plated Snuff Box maker.
Hoyland John & Co.	Do. Union Street ...	Platers, Refiners, Button and Box makers.
Kirk Joseph	Do. at the Wheat Sheaf, Waingate	Silversmith.
Margreave, Marsden & Brocklesby	Do. above the Town Head Crofts	Silver and Bristol Stone Sleeve Button makers.
Marsden William	Do. White Croft... ..	Plater.
Morton Thomas	Do. New Church Street	Plater.
Morton Richard & Co.	Do. Fargate	Platers & Silver Manufacturers.
Rowbotham John & Co.	Do. Norfolk Street ...	Silversmiths and Platers.
Tonks William	Do. West Bar Green ...	Plated Buckle and Spur maker.
Tudor & Leader	Do. Sycamore Hill ...	Silver & Plated manufacturers of Pitchers, Coffee Pots, Candlesticks, Tureens, Waiters, &c.
Wilson Joseph	Do. Highfield	Silversmith, Plater, Saw maker, Tobacco and Snuff manufacturer.
Winter, Parsons & Hall	Do. High Street	Silversmiths and Platers.
Boulton Matthew	Birmingham, Soho Works ...	Silversmith and Plater.
Ryland Wm.	Birmingham	Plater.



(FROM BIRMINGHAM DIRECTORY FOR THE YEAR 1777.)















Name of Firm.	No Maker's Marks Used.	Location.	Trade Description.
Boulton Matthew	Birmingham, Soho Works ...	Silver and Plate manufacturer.
Ryland William	Birmingham	Plater.

EXTRACTS FROM LISTS OF MANUFACTURERS FROM "BAILEY'S NORTHERN DIRECTORY,"
AND OTHER SOURCES, 1781.



Name of Firm.	No Maker's Marks Used.	Location	Trade Description.
Allen Thomas	Sheffield, Bailey Street ...	Snuffer maker.
Ashforth, Ellis & Co.		Platers.
Burdett John	Do Pea Croft	Brass Dog Collar. Silver Sleeve Button, Silver-plated & Metal Seal Maker.
Henfrey John		Fine Scissor & Snuffer maker.
Henfrey Samuel	Do. Spring Street ...	Steel Spring Snuffer, Scissor and Steel Cat maker.
Holy Daniel & Co....	Do. Norfolk Street ...	Platers.
Kippax & Nowill	Sheffield, (Nowill & Kippax, High Street in 1787)	Wholesale Cutlers and Silversmiths.
Law Thomas & Co....	Sheffield, Norfolk Street ...	Platers and Silver Cutlers.
Littlewood John	Do. Westbar Green ...	Manufacturer of Silver-handled Knives and Forks.
Madin & Trickett	Do. Farfield, near ...	Cutlers and Platers.
Mappin Jonathan	Do. Fargate	Plater and Cup Maker.
Roberts, Eyre & Co.	Do. Union Street... ..	Silversmiths and Platers.
Rowbotham John	Do. Norfolk Street ...	Silversmith and Cutler.
Sykes John & Dennis	Do. (Pinstone Lane in 1787)	Manufacturers of Wood, Ivory, Silver & Plated Table Knives and Forks.
Tudor & Leader	Do. Sycamore Hill ...	Silversmiths and Platers.
Winter, Parsons & Hall	Do. Market Place ...	Platers.
Withers Benjamin & Co.	Do. Pinstone Cross Lane	Manufacturers of Silver, Ivory, Plated and Wood Handled Knives & Forks, and Stamped Pen Knives.
Younge, Greaves & Hoyland	Do. Union Street... ..	Silversmiths and manufacturers of Plated Wares and Buttons.
Fenton, Creswick & Co.	Do. Mulberry Street ...	Silversmiths and Platers.
Boulton & Fothergill	Birmingham, Soho Works and Green Lettice Lane, Cannon Street London	Manufacturers of Hardware.
Ryland William	Birmingham	Plater.

LIST OF MAKERS AND MARKS USED BY MANUFACTURERS OF FUSED PLATED AND CLOSE PLATED ARTICLES AFTER THE PASSING OF THE ACT OF 1784.

The words "close plater," given in this list, signify that the makers so described made articles plated on iron or steel. An account of the methods of manufacture by this process and illustrations are given on pages 6, 7 and 8 of this work. Marks struck on close plated articles can usually be identified by the splitting up or duplicating in various ways of the makers' names, initials, and devices, forming separate shields as  and . Different forms of the letters s and p.s. were used to denote steel, or plated steel. The dates recorded are the earliest that can be traced of firms using their marks. The trade descriptions are taken from old manuscripts, ledgers and directories. Where a § is fixed against a device it signifies that this mark was not registered at the Sheffield Assay Office. The abbreviation "B.M." (in trade description) signifies Britannia Metal.

















Name of Firm.	Maker's Marks.	Date.	Location.	Trade Description.
Ashforth G. & Co. ...		1784	Sheffield, Angel Street ...	Platers and Silversmiths
Fox T. & Co. ...		1784	Do. ...	Do. do.
Green W. & Co. ...		1784	Do. Eyre Street ...	Do. do.
Holy D., Wilkinson & Co.		1784	Do. Mulberry Street	Do. do.
Law T. & Co. ...		1784	Do. Norfolk Street ...	Do. do.
Parsons J. & Co. ...		1784	Do. Market Place ...	Do. do.
Smith N. & Co. ...		1784	Do. Waingate ...	Do. do.
Staniforth, Parkin & Co.		1784	Do. ...	Platers and Cutlers
Sykes & Co. ...		1784	Do. Pinstone Lane ...	Platers and Silver Cutlers
Tudor, Leader & Nicholson		1784	Do. Sycamore Hill ...	Platers and Silversmiths
Boulton M. & Co. ...		1784	Birmingham, Soho Works	Do. do.
Dixon T. & Co. ...		1784	Birmingham ...	Platers
Holland H. & Co. ...		1784	Do. ...	Platers and Silversmiths
Moore J. ...		§ 1784	Do. ...	Plater and Silversmith
Smith & Co. ...		1784	Do. ...	Platers

§ Unregistered marks.

Name of Firm.	Maker's Marks.	Date.	Location.	Trade Description.
Beldon, Hoyland & Co...		1785	Sheffield	Platers and Silversmiths
Brittain, Wilkinson & Brownill		1785	Do.	Do. do.
Deakin, Smith & Co. ...		1785	Do. Hawley Croft ...	Do. do.
Love J. & Co. ... (Love, Silverside, Darby & Co.)		1785	Do. Pea Croft ...	Do. do.
Morton R. & Co. ...		1785	Do. Brinsworth Orchard ...	Do. do.
Roberts, Cadman & Co.		1785	Do. Eyre Street ...	Do. do.
Roberts J. & S. ...		1786	Do. Union Street	Do. do.
Sutcliffe R. & Co. ...		1786	Do. King Street	Do. do.
Bingley W. ...		1787	Birmingham	Plater
Madin F. & Co. ...		1788	Sheffield, Far Field ...	Platers and Silversmiths
Jervis W. ...		1789	Do. White Croft ...	Plater and Silversmith
Colmore S. ...		§ 1790	Birmingham	Plater
Goodwin E. ...		1794	Sheffield, The Park ...	Plater and Silversmith
Watson, Fenton & Bradbury		1795	Do. Mulberry Street	Platers and Silversmiths
Froggatt, Coldwell & Lean		1797	Do. Eyre Street ...	Platers, Silversmiths, & B.M. manufactrners
Green J. & Co. ...		* 1799	Do. Market Place ...	Platers and Silversmiths
Goodman, Gainsford & Fairbairn		1800	Do. 18, Hawley Croft	Platers, Silversmiths and Factors
Ellerby W. ...		§ 1803	London	Close Plater
Garnett W. ...		1803	Sheffield, Bridge Houses...	Plater
Holy D., Parker & Co. ...		1804	Do. Mulberry Street	Platers and Silversmiths

* Green, Roberts, Moseley & Co. This firm commenced from this date to use the mark formerly struck by their predecessors J. Parsons & Co.

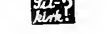
§ Unregistered marks.

Name of Firm.	Maker's Marks.	Date.	Location.	Trade Description.
Newbould W. & Son ...		1804	Sheffield, The Moor ...	Platers
Drabble I. & Co. ...		* 1805	Do. Eyre Street ...	Platers and Silversmiths
Coldwell W. ...		1806	Do. do. ...	Plater, &c.
Hill D. & Co. ...		§ 1806	Birmingham ...	Close Platers
Law J. & Son ...		† 1807	Sheffield ...	Platers
Butts T. ...		1807	Birmingham ...	Close Plater
Green J. ...		1807	Do. ...	Do.
Hutton W. ...		‡ 1807	Do. ...	Do.
Law R. ...		1807	Do. ...	Do.
Linwood J. ...		1807	Do. ...	Do.
Linwood W. ...		1807	Do. ...	Do.
Meredith H. ...		1807	Do. ...	Do.
Peake ...		1807	Do. ...	Do.
Ryland W. & Son ...		§ 1807	Do. ...	Platers, Close Platers and Silversmiths
Scot W. ...		§ 1807	Do. ...	Close Plater
Silkirk W. ...		1807	Do. ...	Do.
Thomason E. & Dowler...		§ 1807	Do. ...	Close Platers, &c.
Tonks Samuel ...		1807	Do. Bromsgrove Rd.	Plater

* Previous to this date this mark was used by D. Holy, Wilkinson & Co.

† Tudor & Co. having retired from business in 1804, this would appear to be a re-registration of their mark by J. Law & Son at the Sheffield Assay Office in 1807. ("See Old Sheffield Platers and their marks, page 7.")

‡ See also 1831, 1837, 1839, 1849.

|| These marks were probably used at a later date.

§ Unregistered marks.

Name of Firm.	Maker's Marks.	Date.	Location.	Trade Description.
Waterhouse & Co. ...		1807	Birmingham	Platers and Silversmiths
Wilmore Joseph ...		§ 1807	Do.	Plater, Worker and Silversmith
Gainsford R. ...		1808	Sheffield	Plater, Close Plater and Silversmith
Hatfield A. ...		1808	Do. Pepper Alley ...	Close Plater and Silversmith
Banister W. ...		1808	Birmingham	Close Plater
Gibbs G. ...		1808	Do.	Do.
Hipkiss J. ...		1808	Do.	Close Plater and Silversmith
Horton D. ...		1808	Do.	Close Plater
Lea A. C. ...		1808	Do.	Close Plater and Silversmith
Linwood M. & Sons ...		1808	Do.	Do. do.
Nicholds J. ...		1808	Do. 13, Foredrough Street	Maker of Plated Liquor and Cruet Stands, Teapots, Curbs, Spoons, etc.
Beldon G. ...		1809	Sheffield	Plater
Wright J. & Fairbairn G.		1809	Do.	Platers and Silversmiths
Cheston T. ...		1809	Birmingham	Plater and Silversmith
Harrison J. ...		1809	Do.	Plater
Hipwood W. ...		1809	Do.	Close Plater
Horton J. ...		1809	Do.	Plater and Silversmith
Silk R. ...		1809	Do.	Close Plater
Howard S. & T. ...		§ 1809	London	Do.
Smith, Tate, Nicholson & Hoult		1810	Sheffield, Arundel Street...	Platers and Silversmiths
Dunn G. B. ...		1810	Birmingham	Close Plater of Dessert Knives and Forks, Spoons, Ladles, Fish Knives, Snuffers, etc.

§ Unregistered marks.

Name of Firm.	Maker's Marks.	Date.	Location.	Trade Description.
Hanson M.		1810	Birmingham	Close Plater
Pimley S.		1810	Do.	Close Plater
Creswick T. & J.		1811	Sheffield, Porter Street	Platers and Silversmiths
Stot B.		1811	Do. Duke St., Park	Close Plater
Watson, Pass & Co. (late J. Watson)		1811	Do. Hartshead	Platers and Silversmiths
Lees G.		1811	Birmingham	Fancy Plater
Pearson R.		1811	Do. Princes Street	Plater in general
White J. (White & Allgood)		1811	Do.	Platers and Military Ornament makers
Kirkby S.		1812	Sheffield, Carver Lane	Plater and Silversmith
Allgood J.		1812	Birmingham, Essex Street	Close Plater
Allport E.		1812	Do. Cannon Street	Do.
Gilbert J.		1812	Do. Legge Street	Do.
Hinks J.		1812	Do.	Plater and maker of Plated articles
Johnson J.		1812	Do. New Inkleys	Sword Hilt maker and Steel worker
Small T.		1812	Do.	Plater in general and Japanner
Smith W.		1812	Do.	Jeweller and Button maker
Younge S. & C. & Co.		1813	Sheffield, Union Street	Platers and Silversmiths
Thomas S.		1813	Birmingham, 45, Thorp-st.	Close Plater
Tyndall J.		1813	Do. Moseley St.	Do.
Best H.		1814	Do. Great Charles-st.	Do.
Cracknall J.		1814	Do.	Plate maker, Table and Tea Spoons, Sugar Tongs, Caddie Shells, &c.
Jordan T.		1814	Do.	Close Plater

* Found on close plated goods, the initials are also found on silver goods.

† Found on close plated goods. § Unregistered marks.

Name of Firm.	Maker's Marks.	Date.	Location.	Trade Description.
Woodward W. ...		1814	Birmingham, Bishopgate Street	Close Plater
Lilly John ...		1815	Birmingham, St. Paul's Square	Close Plater and Military Ornament maker
Best & Wastidge ...		1816	Sheffield ...	Platers
Ashley ...		1816	Birmingham ...	Do.
Davis J. ...		1816	Do. ...	Japanner
Evans S. ...		1816	Do. ...	Maker of Plated articles
Freeth H. ...		1816	Do. Upper Priory ...	Plater
Harwood T. ...		1816	Do. ...	Close Plater
Lilly Joseph ...		1816	Do. ...	Plater and maker of Curbs, Spoons, &c.
Turley S. ...		1816	Do. ...	Plater and maker of plated articles
Cope C. G. ...		1817	Do. Edmond Street	Do. do.
Pemberton & Mitchell ...		1817	Do. ...	Jewellers, Silversmiths, Watch and Clock makers
Shephard J. ...		1817	Do. ...	Maker of Plated Coach Harness, Furniture, Bits, Stirrups, Knives and Snuffers
Markland W. ...		1818	Do. ...	Maker of Plated Spoons, Tongs, Caddie Shells, Tea Canisters, Soup, Toddy, and Punch Ladles, Teapots, Sugar Basins, Cake, Fruit and Bread Baskets, Plated Saddle Nails, &c.
Corn J. & J. Sheppard...		1819	Do. Exeter Row ...	Close Platers
Rogers J. ...		1819	Do. New Street ...	Harness Plater
Hall W. ...		1820	Do. ...	Close Plater
Moore F. ...		1820	Do. William Street ...	Fancy Plater
Turton J. ...		1820	Do. 8, Church Street	Close Plater and maker of fused Plated Tea Spoons and Tongs

* These marks were probably used at a later date. § Unregistered marks.

Name of Firm.	Maker's Marks.	Date.	Location.	Trade Description.
Blagden, Hodgson & Co.		§ 1821	Sheffield, Nursery Street...	Platers and Silversmiths
Holy D. & G. ...	 HOLY D. & G. SHEFFIELD	* 1821	Do. Mulberry Street	Do. do.
Needham C. ...	 NEEDHAM SHEFFIELD	§ 1821	Sheffield, Willey Street ...	Maker of Plated Tankards and Measures
Sansom T. & Sons ...	 SANSON	1821	Do. ...	Maker of Plated goods
Child T. ...	 CHILD	1821	Birmingham ...	Plater and Pawnbroker
Smith I. ...	 SMITH	1821	Do. ...	Close Plater and Harness Buckle maker
Worton S. ...	 S. WORTON	1821	Do. Near the Five Ways	Close Plater
Rodgers J. & Sons ...	 J. R. G. R. RODGERS	1822	Sheffield, Norfolk Street...	Cutlers, Silver Cutlers and Factors
Bradshaw J. ...	 BRADSHAW	1822	Birmingham, 3, Goff St...	Close Plater
Briggs W. ...	 BRIGGS	§ 1823	Sheffield, Carver Street ...	Silversmith and Plater
Harrison G. ...	 GH	§ 1823	Birmingham ...	Close Plater
Smallwood J. ...	 SMALLWOOD	§ 1823	Do. ...	Do.
Causer J. F. ...	 CAUSER	1824	Do. 4, Nicholson St.	Merchant and Factor
Jones ...	 JONES	1824	Do. Show room, New Street	Gold and Silversmith, Medallist, &c.
Tonks & Co. ...	 TONKS	1824	Birmingham ...	Close Platers
Roberts, Smith & Co. ...	 ROBERTS	1828	Sheffield, 5, Eyre Street ...	Platers and Silversmiths
Smith J. & Son ...	 SMITH	§ 1828	Do. Arundel Street...	Cutlers and Silversmiths
Askew ...	 A SKEW MAKER NOTTINGHAM	§ 1828	Nottingham ...	Maker of Plated Tankards and Measures
Hall Henry ...	 HALL	§ 1829	Birmingham, 51, Shadwell Street	Close Plater
Hobday J. ...	 HOBDAY	§ 1829	Birmingham ...	Do.
Watson J. & Son ...	 WATSON	1830	Sheffield ...	Platers and Silversmiths

* Mark used on plated handled cutlery on steel blade is stamped "D. & G. HOLY, SHEFFIELD."

§ Unregistered marks.

Name of Firm.	Maker's Marks.	Date.	Location.	Trade Description.
Bishop Thomas...		§ 1830	Birmingham, 24, St. Paul's Square	Goldsmith and Jeweller
Hutton W. ...		* 1831	Sheffield	Close Plater
Atkin Henry ...		§ 1833	Do. 32, Howard St....	Gold, Silver and Plated Cutlery manufacturer
Waterhouse I. & I. & Co.		§ 1833	Sheffield	Platers and Silversmiths
Watson W. ...	W WATSON MAKER SHEFFIELD	§ 1833	Do. 15, Arundel Street (until 1812 partner in firm of Watson & Bradbury)	Plater and Silversmith
Dixon J. & Sons		§	Do. Cornish Place ...	Makers of Plated Silver and B.M. goods
		§		
		§		
		§ 1835		
		§		
Smith J. ...		§ 1836	Do. 48, South Street	Maker of Plated Tankards and Measures
Waterhouse, Hatfield & Co.		§ 1836	Do. Portobello Place	Platers and Silversmiths
Wilkinson H. & Co. ...		† 1836	Do. Norfolk Street ...	Do. do.
Hutton W. ...		‡ 1837	Do.	Close Plater
Hutton W. ...		1839	Do.	Do
Prime J. ...		§	Birmingham	Close Plater
		§		
		§		
		§		
Walker, Knowles & Co.		§ 1840	Sheffield, 47, Burgess St.	Platers and Silversmiths
Waterhouse George & Co.		§ 1842		
Smith, Sissons & Co. ...		§ 1848	Do. 5, Eyre Street ...	Do. do.
Padley, Parkin & Co. ...		§ 1849	Do. Watson Walk	Do. do.





* See also 1807, 1837, 1839, 1849.

† The cross keys mark is registered this year at the Sheffield Assay Office for the third time.

‡ This mark was originally registered by Scot in 1807; for previous marks used by Hutton see 1807, 1831.

|| The same firm as above, and in 1831 but with the 1807 mark reversed.

§ Unregistered marks.

Name of Firm.	Maker's Marks.	Date.	Location.	Trade Description.
Hutton W.	 *	1849	Sheffield	Close Plater
Mappin Bros.	 †	1850	Do. Baker's Hill ...	Silver and Plated Cutlery Manufacturers
Oldham T.	 §	1860	Nottingham	Maker of Plated Tankards and Measures
Roberts & Briggs ...	 † §	1860	Sheffield, 38. Furnival Street	Silver and Plated Ware Manufacturers

















* See note (||) on previous page.

† Possibly this mark was purchased from M. Boulton & Co., of Birmingham, at their dissolution in 1848.

‡ Since 1863 Roberts & Belk.

§ Unregistered marks.

MISCELLANEOUS MARKS WHICH HAVE NOT BEEN TRACED.

Maker's Marks.	Description of article from which marks are taken.	Approximate date of manufacture.
	Fused Plated 1-pint Tankard	1780-1790
	Do. Sugar Tongs	1790
	Do. Sauce Boat	1790
	Do. Pierced Fish Slice, with Plated Handle...	1790-1800
Do.	Do. Wine Coolers, with Lion Mask Handles ...	1790-1800
 *	Do. Tankard	1800-1810
	Do. Folding Ear Trumpet, with Silver Filled Floral Mounts (see page 390.)	1815-1825
	Do. Salt Cellar, with Wire Supports for Glass ...	1815-1825
	Fused Plated 5-light Candelabra, 29 in. high.	1815-1825
	Fused Plated small Telescope (see page 390)	1840
	Fused Plated pointed end Snuffer Tray (see page 328.) ...	1840
	Close Plated Dessert Knife... ..	1840
	Close Plated Article	1840
	Snuffers, made of Argentine Metal, with Filled Silver Mounts...	1850
	Close Plated Dessert Knife	1850
	Do. Marrow Scoop	1850
	Ivory Handled Dessert Knife, Close Plated Blade	1850

* T. Middleton, Rd. Jewesson, G. Ashford and G. Frost are registered, as a firm of silver plate workers, at the Sheffield Assay Office, 2/4/1798.

PART XI.

OTHER INDUSTRIES CONNECTED WITH OLD SHEFFIELD PLATE.

THE MANUFACTURE OF SILVER.

OLD SHEFFIELD AND SILVER-HANDLED CUTLERY.

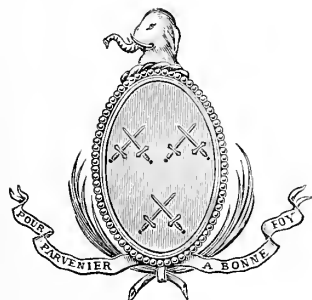

It would be impossible to write exhaustively about Old Sheffield Plate without touching lightly on the subject of cutlery made in Sheffield, since, as before stated, the plated industry grew out of the cutlery trade. It will readily be understood that very little time elapsed after the invention of the new process before table knives, with good serviceable metal handles, were produced in the cutlers' workshops.

The earliest date of the introduction of cutlery with both silver and plated handles can only be conjectured, but by the year 1773 (the date of the establishment of the local Assay Office) this branch of the trade was considerable, as silver-handled cutlery assayed in Sheffield in that year is frequently met with.

The plated handles, though made from stronger metal and more durable, are less frequently found than silver ones. The latter would naturally be preferred if not too expensive. Very thin silver was used in their construction, consequently the extra cost was but trifling. Both plated and silver handles were struck from dies and soldered together in halves, afterwards being filled with shellac poured into them in a molten state. The tangs of the blades and forks were then secured and cemented inside the handles before the composition had set hard.

Formerly the handles do not appear to have been soldered on to the bolsters, the method frequently adopted to-day. No doubt this was because the extra strength of metal required would have more than doubled the cost of production.

For many years past it has puzzled both collectors and antique silver experts to discover the reason why silver handled cutlery made towards the latter end of the 18th century so often bears the word **STP** stamped on the handles, the only other device being usually a maker's mark. Also, if of sterling or 925* silver, then why no hall mark? And again,

* The proportions of English "Standard" silver are 925 parts pure silver to 75 of alloy (per 1,000).

whose are the initials that are to be found thereon? The answer to these queries is that under Act 30, Geo. III., cap. 31, articles of less than 5 dwts. in weight had not of necessity to be hall marked unless particularly specified in the Act and knife and fork handles did not come under any particular specification. Now in almost all cases the weight of these handles did not exceed 15 to 20 dwts. per dozen, therefore they were exempted under the enactment. It will be found on carefully removing these handles from the blades and forks that in the majority of instances where they have been stamped with the word **STER** the weight of silver is not much in excess of 1 dwt. per handle. It is not uncommon to find the word **STERLING** stamped on silver plate manufactured in other towns of Great Britain and Ireland, though it occurs chiefly on silver manufactured in Cork and Limerick. An unusual instance of the use of this word has been taken from the bases and nozzles of a pair of silver candlesticks found in Ireland:—on bases,

TL **STER** **TL**; on nozzles, **LAW** **STER** **LING**. No similar instance has hitherto been met with.

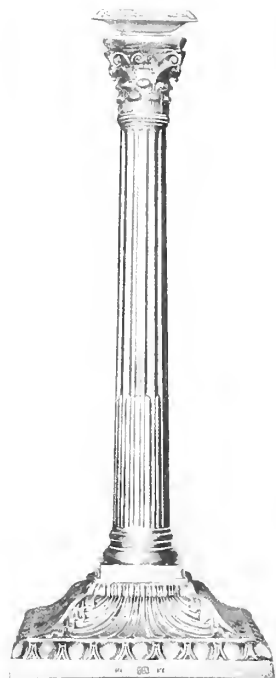

12 in. Silver Corinthian Candlestick,
by T. Law, Sheffield.
Date 1765. E. Johnson, Dublin.

There need be no hesitation in assigning these candlesticks to a Sheffield manufacturer. There was, it is true, a Dublin silversmith, "William Law" referred to on pages 148 and 153), but an examination of dates shows that the articles here described cannot be his, for in the year of their manufacture, 1765, he was only commencing his apprenticeship, and not until 1774 did he take out his freedom. Further, excepting the word "sterling," the marks above given have all been met with previously on plated candlesticks made by Thomas Law, of Sheffield (see page 34), before the year 1773. The initials "**TL**" it will be observed correspond exactly with those found on the lid and at the side of an old Sheffield plated tankard illustrated on page 425 of Part X., manufactured by Law, of Sheffield, a few years later than the date ascribed to the candlesticks, whilst the name "Law" is also to be seen on the base of a candelabrum shown on page 232.

The initials frequently met with on thin silver-handled cutlery are usually those of some Sheffield silversmith, who stamped his silver punch

on the handles with the word **STERLING**, or occasionally put on the mark of the customer for whom he made the goods. The heavier silver handles formerly supplied by the London cutlers were fashioned partly by hand and partly by means of cast metal dies; they were almost entirely superseded by the far less costly Sheffield productions.

Having so far found that the majority of the punches tally exactly with those registered by the Sheffield manufacturers, we must conclude that the silver handled and plated cutlery was made almost exclusively in Sheffield. The manufacture of this class of cutlery would present great difficulties to anyone not conversant with the local industry, being a particular trade that may aptly be described as indigenous to the district. We must also negative the supposition often put forward that these articles were produced in the city of Cork,* though the silversmiths there used a mark **STERLING** for their silver goods resembling that adopted by the Sheffield cutlers.

Amongst the marks met with on the handles of Old Silver cutlery with steel blades and forks, which in most instances correspond with the punches registered by the silver cutlers at the Sheffield Assay Office, mention should be made of

JSR	STERLING	J. & S. Roberts	..	1765	W.B.S.	STERLING	Madin & Tricket	..	1779
R.T.		„ Robert Tricket	..	1773	R.S.		„ Robert Sutcliffe	..	1781
W.B. & Co.		„ W. Birks & Co.	..	1773†	SYKES & Co.		„ Sykes & Co.	..	1781
IR		„ John Rowbotham	..	1776†	W.B.S.		„ W. Birks & Son	..	1781‡

The mark **CS**, often found on silver handled cutlery of the pistol pattern, may perhaps be attributed to J. Parsons & Co., in which firm there were at one time five partners.§ Another mark, **CS** **STERLING** frequently found on cutlery made in Sheffield has so far not been traced.



Steel-bladed Table Knife, 10 3/4 in. long, blade marked "MADIN." handle of filled silver bearing marks **M.T.** **S** **CS**
 Date 1779. Author.

* See Journal of the Cork Historical and Archeological Society, vol. xii., second series, 1906. "The Goldsmiths of Cork," by M. S. D. Westropp.

† Birks & Rowbotham were associated in business in 1774-1781.

‡ In the Assay Office Register of this date this mark is given as in 1773, probably in error, as the one here reproduced has been taken from a silver handled table knife of Birks' manufacture.

§ Further particulars concerning the firm are given on page 42.

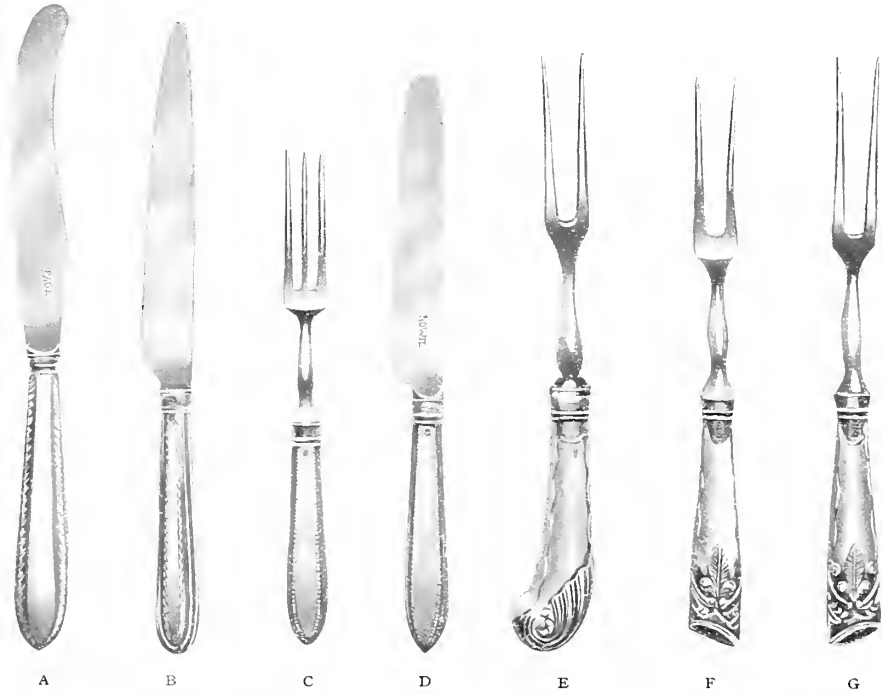

A—Old Sheffield Plated Knife Handle, with Steel Blade, marked PAGE—Date 1780. B—Steel Bladed Knife, with Silver-filled Handle, by Robert Trickett.—Date 1779. C & D—Steel Bladed Knife and 3-prong Fork, with Silver-filled Handles, by W. Hoyland, and Blade by T. Nowill.—Date 1786 (see page 460). E—2-prong Steel Fork, with Silver-filled Pistol Handle, by Thomas Warris—Date 1796. F & G—Obverse and reverse of 2-prong Steel Fork, by Madin & Trickett,  Date 1780.

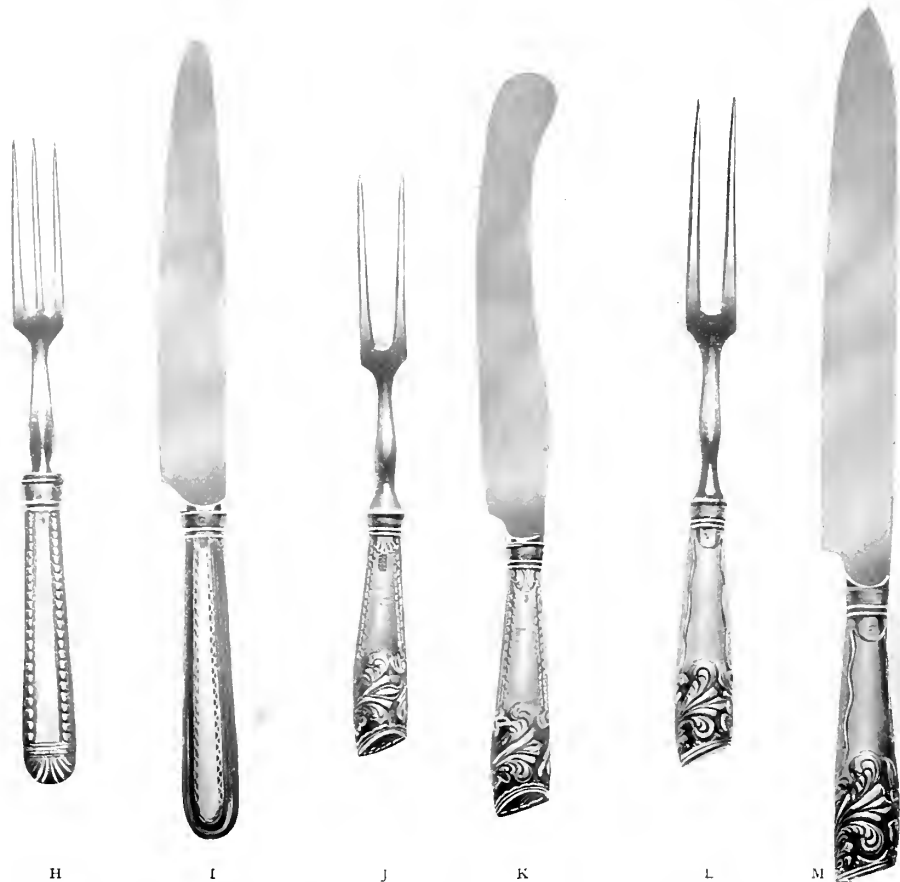

H—Steel 3-prong Fork, with Silver-filled Handle, by Robert Trickett.—Date 1776. I—Steel Bladed Knife, with Silver-filled Handle, by Robert Trickett.—Date 1778. J & K.—Knife and Fork, with Silver-filled Handles, marked  Date 1785. L & M.—Steel Bladed Knife and 2-prong Fork, with Silver-filled Handles, by Sykes & Co.—Date 1792.





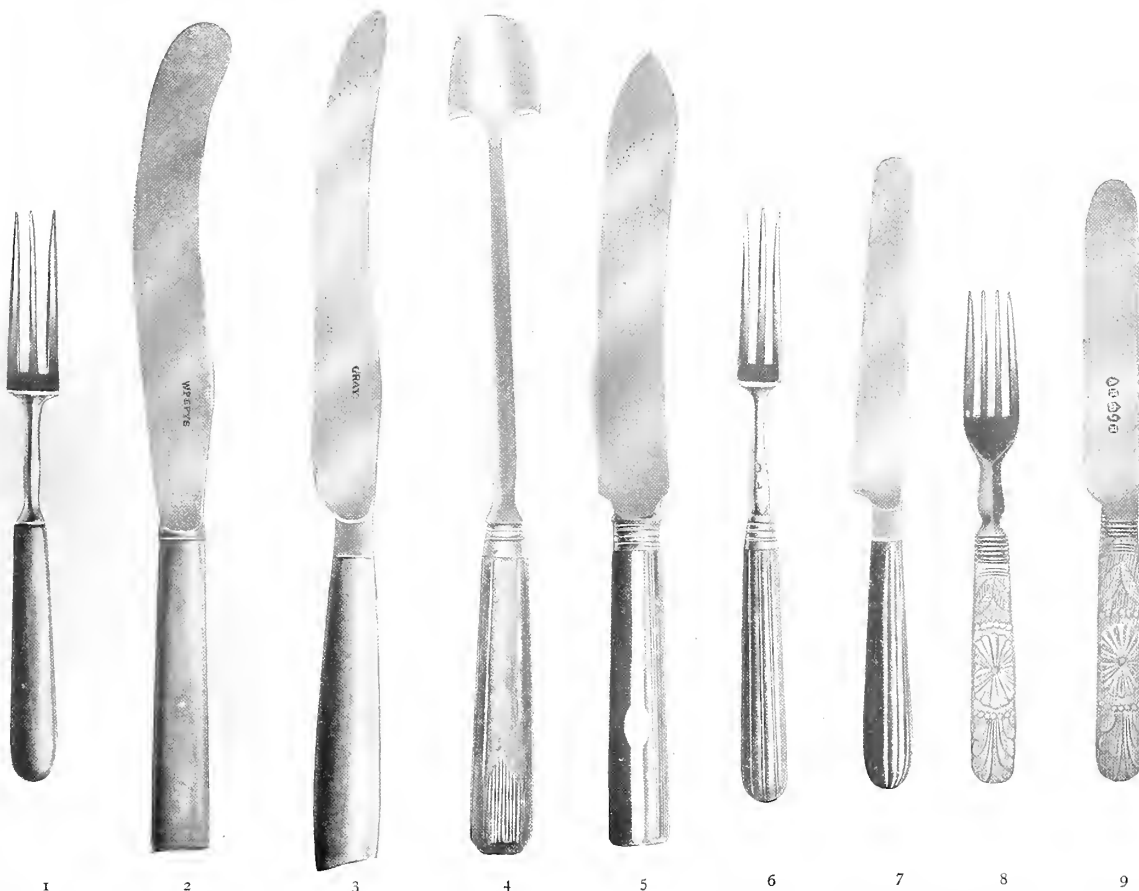

IVORY STAINED GREEN FOR KNIFE HANDLES AND OTHER PURPOSES.

A few examples of the well-known Sheffield-made old green stained ivory handled cutlery are shown for the reason that these articles were usually manufactured by the "silver cutlers," and are often met with stamped with their name. They are sometimes also found with silver, and silver-plated ferrules to the bolsters and occasionally with solid silver forks. The idea of this green stained ivory cutlery does not appear to have originated (as is generally supposed) from the fact that ivory was so cheap in the middle and latter part of the 18th century that people grew tired of seeing it in use, but probably because when stained it showed no dirty or greasy marks. Another reason for it was also an attempted resemblance to the mineral malachite, the vivid green colour of which it was the primary object of the cutlers to attain. In fact, when the ivory was thoroughly and carefully stained and polished, the likeness was complete. Moreover the use of stained green ivory made a pleasing departure from the black and brown wood and horn used for teapot and kettle handles and knobs, etc., on pieces of Old Sheffield Plate.

















1 2 & 3—Stained Green Ivory Knives and Fork, with Steel Blades.—Date 1780-1790. 4—Carved and Stained Green Ivory, Close-plated Cheese Scoop.—Date 1805. 5—Steel Bladed Knife, with Stained Green Ivory Handle and Inlaid Silver Ornamentation.—Date 1800-1810. 6 & 7—Silver Fork, with Stained Green Ivory Handle.—Date 1805, also Knife with Steel Blade. 8 & 9—Carved White Ivory Handled Close-plated Dessert Knife and Fork, by A. Hatfield.—Date 1809.

Though not classified under the heading of "Silver and plated manufacturers," the following list of names and marks of cutlers, etc. (connected with the silver and Sheffield plated industry), are found on the pages of Sketchley's Sheffield Directory, 1774.

Name of Firm.	Corporate Marks granted by the Cutlers' Company for use on blades, &c.	Date.	Location.	Trade description.
Ashforth, Ellis & Co. ..	 L'ESPAGNE	1774	Sheffield, Holy Croft ..	Cutlers and Plated manufacturers.
Birks, Withers & Sykes	 SYKES	1774	Do. Pinston Croft Lane	Wood, Ivory and Silver Handle Table Knife.
Dewsnop Joshua ..		1774	Do. Trinity Street	Silver Cutler.
Lambert William ..		1774	Do. Pond Lane ..	Silver Cutler and Ornament maker.
Law Thomas	LAW	1774	Do. Norfolk Street	Silver Cutler, Silversmith and Plater.
Laycock Thomas ..		1774	Do. Pond Lane ..	Gilt, Plated and Metal Button maker.
Littlewood John ..	 MADIN & OPUS	1774	Do. Westbar Green	Silver Cutler.
Madin & Trickett ..		1774	Do. Farfield ..	Cutlers and Platers.
Nowill Joseph	GENEVA	1774	Do. Pea Croft ..	Cutler.
Roberts Jacob & Samuel	 ABBA	1774	Do. Pond Hill ..	Table Knife Cutlers.
Roberts Sam		1774	Do. New Church Street	Cutler, Silversmith and Plater.
Roberts, Elam, Winter & Co.		1774	Do. near Fargate ..	Silver Cutlers.

This list of marks must not be confounded with those illustrated in Part X. and which were used by the manufacturers solely on fused plated and close plated goods. The marks reproduced above and on next page are to be met with only on the blades, etc., of steel cutlery, with ivory, bone, horn, stag, or wood handles. Those given on subsequent pages (chiefly in form of initials) were exclusively for use on articles of sterling silver. From these various lists the inference is drawn that the majority of early Sheffield manufacturers were at the same time cutlers, platers, and silversmiths. While the marks used on steel cutlery had to be registered with the Sheffield Cutlers' Company, those for plated and silver wares had to be recorded at the Sheffield Assay Office. The miscellaneous marks at foot of page 460, are typical of a form of unregistered marking that came into vogue more particularly on articles of plated cutlery (see page 440), towards the termination of the Sheffield plate industry.



Gales and Martin, in their Directory of Sheffield, for the year 1787, record the subjoined list of table knife makers, "silver and plated," with the accompanying corporate marks, as granted to them by the Sheffield Cutlers' Company :—

Name of Firm.	Corporate Marks granted by the Cutlers' Company for use on blades, &c.	Date.	Location.	Trade description.
Beldon, Hoyland & Co.	PLUTUS 	1787	Sheffield, Burgess Street	Plated and Silver Table Knife makers.
Birks William and John	 FABRE	1787	Do. Norfolk Street	Do.
Dewsnap John	 SOUND	1787	Do. Queen Street..	Do.
Dewsnap Joshua ..	 SOUND	1787	Do. Trinity Street	Do.
Green William & Co. ..	W. GREEN & Co 	1787	Do. Eyre Street ..	Do.
Hoyland, Clarbour & Barnard	 SUPER z c CLARBOUR + SURIUS	1787	Do. Hillfoot ..	Do.
Hunter & Twigg ..	WATCH HUMBLE	1787	Do. Black Lane ..	Do.
Law Thomas & Co. ..	 LAW L&CO. ARGENT	1787	Do. Norfolk Street	Do.
Littlewood John ..	 +	1787	Do. Silver Street ..	Do.
Roberts Jacob & Samuel	 + PAPA + ABBA	1787	Do. Union Street ..	Do.
Settle Thomas & Co. ..	 SET	1787	Do. Brinsworth's Orchard	Do.
Smith Nathaniel & Co.	N + 	1787	Do. Waingate ..	Do.
Staniforth, Parkin & Co.	 PARKIN SHEMEL	1787	Do. Sycamore St...	Do.
Sutcliffe, Sporle & Co...	S. S. & Co.	1787	Do. King Street ..	Do.
Sykes & Co.	SYKES 	1787	Do. Pinston Lane..	Do.
Tricket, Haslehurst, Whiteley & Pryor	 OVA OPUS	1787	Do. Hillfoot ..	Do.



W. Green & Co., mentioned as using the pistol mark for cutlery, were the first firm to register their mark for plated wares—also the pistol—September 8th, 1784. They were perhaps singular in registering the same mark for two kinds of goods.

T. Settle & Co. had no separately registered mark for plated goods, though there are no less than 12 registrations of silver marks in connection with the name "Settle" or "Sattle" between the years 1773 and 1825 at the Sheffield Assay Office. Their successors, "H. Wilkinson & Co.," re-registered the cross keys mark for plate in 1836.

"Nathaniel Smith & Co." was probably the same firm mentioned before as in Waingate, 1756 (see page 441). Their plate mark—the hand—has been fully dealt with in Part X. Beldon, Hoyland & Co., Staniforth, Parkin & Co., Thomas Law, J. & S. Roberts, Sykes & Co., and Sutcliffe & Co., have all previously been recorded in the lists of makers in Part X., who registered marks for plated goods subsequent to the year 1784.

The firm "Joseph Nowill," is of considerable local interest. As cutlery manufacturers the Nowills are perhaps the oldest makers still existing in Sheffield. More old steel blades bearing their marks are to be found than is the case with any other manufacturer. From 1645 down to the present time "the Nowills" (their name spelt in various ways) are consistently recorded in the lists of apprentices and freemen of the Cutlers' Company. Thomas Nowill was Master Cutler in 1788, having registered the mark  as a silversmith at the Sheffield Assay Office in 1786. Joseph "Nowell" registered the mark  for silver at the Sheffield Assay Office in 1813. Besides the firm mentioned as of Peacroft, there was also "Kippax & Nowill" for many years prominent tradesmen in High Street, Sheffield.

MISCELLANEOUS CUTLERY MARKS (UNREGISTERED).

Name of Firm.	Makers' Marks.	Approximate Date of Manufacture	Location.	Description of Article from which Marks are taken.
J. Smith & Son	 JSMITH EXTRA	1829	Sheffield, Arundel Street	Silver-handled Steel Bladed Table Knife.
James Bradbury	G BRADBURY	1833	Do. 57, Eyre Street	Large Table Knife with stained green ivory handle.
* ?		1840	Do.	Table Knife with close plated blade and silver handle.

* Attention has previously been drawn to this mark on page 440.

ANTIQUe SILVER IN SHEFFIELD.

The earliest piece of silver known to have had any connection with Sheffield was purchased at the Massey Mainwaring sale at Christie's, in the year 1907, and is the watch illustrated. The case bears no hall mark, but an interesting mark, somewhat resembling the crown, is on the inside of the case. The date of the manufacture of the watch would be Queen Anne's time, or rather later. It bears the name on the face "Travis, Sheffield," and also inside, "Josiah Travis, Sheffield,"—notice the quaint spelling of Sheffield at this period (in two different ways). Nathaniel Travis, possibly grandson of the maker—or more probably only vendor—of this watch, was registered as a silver manufacturer at the Sheffield Assay Office in 1789.* Perhaps someone else may be able hereafter to throw further light on this article. Mr. R. E. Leader furnishes a clue to the date of the Josiah Travis' watch, and an interesting glimpse of the maker, contained in an account he recently published of the diary of Richard Carr, a Sheffield attorney, who in 1728-30 was in the office of Mr. Francis Sitwell, clerk to the Sheffield Cutlers' Company. Under date 21st July, 1729, Richard Carr records, "Mr. Travis mended my watch, put in a new spring and glass in, which I have not yet paid him for. He said he must have 6s."



Antique Silver Watch, bearing the name "Travis, Sheffield," manufactured between the years 1710-1725.

* In Sketchley's Sheffield Directory for 1774 occurs "Travis Nathaniel, penknife cutler, Whitecroft, mark ^{IN} _{BILBO.}"

It has not been considered necessary to illustrate articles of hollow-ware made in silver assayed in Sheffield, as the majority nearly resemble those that were made in fused plate, which are fully illustrated and described in Part IX. of this work.

The close resemblance of antique silver articles having the Sheffield Hall Mark to those that are to be found in Old Sheffield Plate has already been dealt with on page 200. Almost every article made in silver between the years 1773 and 1840 assayed in Sheffield has its duplicate in Sheffield plate.

During the flourishing days of the manufacture of Sheffield Plate, the making of solid silver goods, although always an increasing industry in Sheffield, was completely overshadowed by the making of plated wares. Thus it came about that owing to the enormous demand that had sprung up for Sheffield Plate, the models for silver articles were at one period copied from the plated ones, completely reversing the position of affairs that existed in the earliest days of the industry and that exists at present in Sheffield.

Illustrations of detachable parts manufactured in sterling silver, bearing Sheffield Assay Office marks, taken from old Sheffield plated articles.

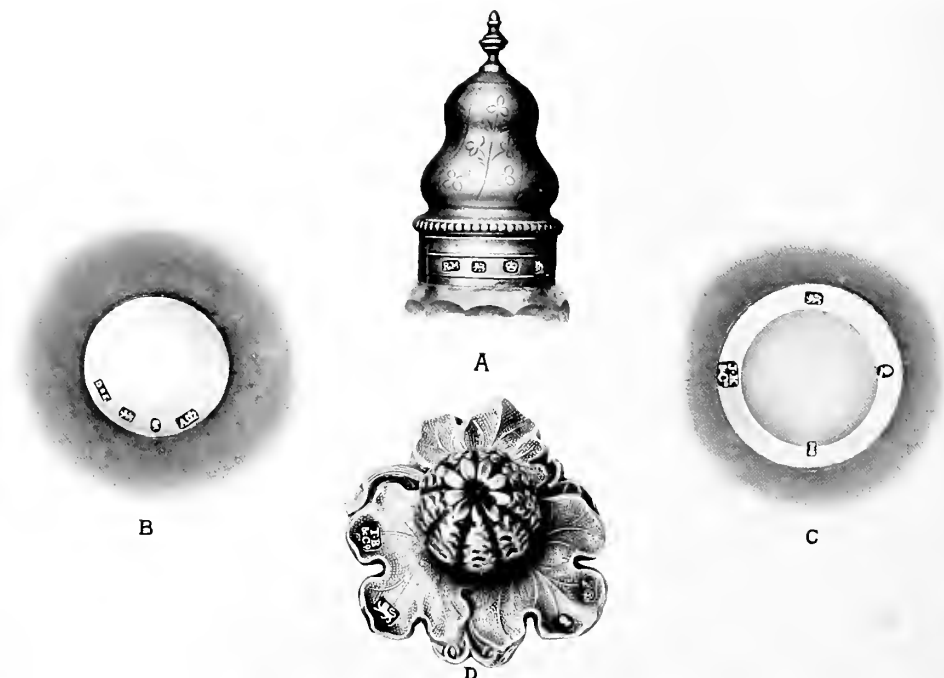

A—Silver top from a plated pierced Cruet, by Richard Morton; date 1777. B and C—Shields from plated coasters. B by J. Dixon & Son, date 1844; C by J. Kirkby & Co., date 1824. D—Knob from plated teapot, by T. Blagden & Co.; date 1830.

Articles of Old Sheffield plate are frequently met with that have in their construction detachable parts fashioned from sterling silver, and hall marked in Sheffield, such as the tops of cruet bottles and the shields for engraving let into the wood bottoms of coasters ; also the knobs of teapots, coffee pots, and kettles. Nozzles for plated candlesticks and various ornaments for plated dessert stands, etc., are also at times to be found made of solid silver and hall marked. Instances can also be given where handles for plated entrée dishes and dish covers have been fashioned in like manner. The centre figure of *épergne* illustrated on page 294, when detached from the upper and lower portions, reveals the Sheffield silver assay mark for the year 1822, with the registered punch of Roberts, Cadman & Co. This hall marking has proved to be invaluable, not alone for fixing the year in which a particular piece was made, but also for definitely ascertaining the name of the manufacturer to whose production an article of Old Sheffield plate may with certainty be ascribed.

THE SHEFFIELD ASSAY OFFICE.*

The office for assaying and marking silver goods in Sheffield was established in the year 1773. For some considerable time previous to this date there had been great agitation on the part of the makers of silver and plated goods for legal sanction to enable them to start an Assay Office in Sheffield. Up to that time the manufacturers were put to the inconvenience, delay, and expense of sending their silver wares almost entirely to London for assaying, and seven of the principal local makers, viz., Matthew Fenton (with Richard Creswick),† William Hancock, John Hirst, John Rowbotham, Henry Tudor, Thomas Tyas, Junr., and John Winter, had found it necessary to register their punches at the London Goldsmiths' Hall.‡ Since the discovery of the process of plating by fusion some thirty years anterior to the commencement of the Sheffield Assay Office, the number of makers of solid silver goods had very greatly increased, and the London Goldsmiths were in consequence quite unable to oppose successfully the very just claims of the local manufacturers in the eventual fulfilment of their wishes.

The marks that were put on Sheffield assayed silver only differed from those in vogue in London in a trifling degree, viz., the crown was substituted as a mark of origin for the leopard's head. The maker's mark, date letter and lion passant were struck with separate punches, as was also customary in London. By the Act 1773 the higher standard, containing 958 parts

* Mr. B. W. Watson, the Sheffield Assay Master, himself a descendant of an Old Sheffield Plate manufacturer and silversmith, has given great assistance in the compilation of the above matter.

† Fenton and Creswick were in partnership (for further particulars, see pages 36 and 37).



‡ For further particulars see Arnold T. Watson's book, "The Sheffield Assay Office," published in 1890.

of pure silver per 1,000 was also authorised to be used in Sheffield, and the figure of Britannia struck as a duty mark. (It has not so far been traced that this mark was ever used in Sheffield during the period under review). The various date letters were, however, stamped somewhat irregularly and did not commence with the first letter of the alphabet, as was the case with the London Hall,  being the first recorded in the year 1773. From the year 1824 the method has been adopted of taking the letters in the order of the alphabet, commencing with the letter a.* The letters i. j. n. o. w. y. were, however, omitted in this first consecutive cycle, and j. q. in the one which followed (commencing with A, in 1844). The next cycle, from 1868 to 1892, omits only one letter, viz., I.

During the 138 years that the Sheffield Assay Office has been in existence the following gentlemen have been appointed to fill the office of Assay Master :



1773. Daniel Bradbury.	1854. John Watson.
1789. George Dickenson.	1878. William Henry Watson.
1807. Samuel Hancock.	1890. Arnold T. Watson.
1809. Matthew Sayles.	1898. Bernard W. Watson, M.A.
1833. Lewis Charles Sayles.	(and at present time).

THE SHEFFIELD ASSAY OFFICE MARKS.







At Assay Offices it is usual to strike various ranges of punches in proportion to the sizes of the articles on which they are to be used. The method adopted is for the manufacturer to strike his initials before sending his goods to be assayed, and afterwards the Assay Master strikes the lion, mark of origin, and date letter as near as possible to the size of the punches he finds on the articles. Many instances can be traced of departure from this custom at our local office in olden times.  The first mark here shown is from the base of a full-sized teapot (date 1817), where not only has the crown been stamped upside down, but the marks used on the teapot are evidently those that should have been struck on the cream jug of the service. The latter, though about one-quarter the size of the teapot, bears a much larger hall mark.  Many similar instances are to be found on Sheffield-made silver of this period. From the year 1815 to 1819 the crown is consistently found stamped upside down.  The most probable explanation of this singular proceeding is that the object in view was to differentiate more clearly between letters that were being used at this period and those struck in earlier years. For example, X is





* The date letter for each succeeding twelve months is changed at the meeting of Guardians held on the first Monday in July, every year.

the date letter for both the years 1797 and 1817, but confusion is avoided by the crown being placed upside down in the latter year. Originally it was the custom for the Assay Master to strike each mark separately, but of late years the method adopted has been to include the lion, mark of origin, and date letter in one punch, though in distinct shields.

The varied sizes and shapes of the crown will be noticed ; but since 1854 these have been uniform. In that year Wyon, who cut the dies for coins at the Mint, undertook the cutting of punches for the crowns used at the Sheffield Assay Office. About 1783 the punches were so carelessly cut that the lion bore great resemblance to a dog,  also they were so casually struck that the local assay mark of this period might easily be mistaken for a forgery. 

An innovation entirely different from the procedures of other offices was the method adopted, dating from the year 1780 and lasting for about 73 years, of stamping the mark of origin and date letter combined in one punch.  Probably originally designed for striking on small articles where space was limited, these punches came eventually to be used at the Sheffield Assay Office on all classes of sterling silver wares.

Another peculiarity not to be found in contemporary articles of silver assayed in London was the frequent omission to strike the assay marks on separate pieces attached to the main bodies by hinges, joints, locks or screws ; as, for instance, on the lids and handles of teapots, jugs and coffee pots,* on handles of sauce tureens, dish covers, entrée dishes, and sugar basins, &c. Although no regulations on this point were definitely laid down by the Act of 1773 these omissions indicate an assay office slackness conspicuously absent to-day. After the death of a Sovereign, the substitution of the succeeding monarch's head as a duty mark was, at the Sheffield Assay Office, considerably delayed. Though Queen Victoria came to the Throne in 1837, the punch bearing the head of William IV. was in use during the whole of the year 1838    and the first six months of 1839   

The duty on silver of 6d. per oz. was imposed in the year 1784, and for about 18 months in Sheffield the sovereign's head, which was added to the other marks, was struck in intaglio instead of low relief      For the greater part of two years this was the usual custom at the Assay Offices in England and Scotland ; whilst from the year 1786 the king's head as a duty mark has always been struck in cameo.†

* The lids of London hall-marked silver coffee pots of the George I., II., and early George III. period are also not unfrequently to be found unassayed.

† In London, King's head in intaglio was struck from December 1st, 1784 to May 29th, 1786. In Sheffield the intaglio head was probably changed in July, 1786.

In Ireland a duty of 6d. per oz. was imposed on silver goods in the year 1730, and the figure of Hibernia  was struck as a duty mark. The king's head (stamped in cameo) was used in Ireland for the first time in 1807 according to Act of Parliament, 47 George III. c. 15, "to regulate the collection of duty on gold and silver plate manufactured in Ireland."

In 1797 the duty on silver was increased to 1s. per oz. From the 13th of July in that year for about nine months, the Sheffield Assay Office stamped the king's head in duplicate,  to denote that this double duty had been paid.

In 1804 the duty was increased to 1s. 3d. per oz., and in 1815 to 1s. 6d. per oz., at which figure it remained until the total abolition in the year 1890.

As, until comparatively recent times, it was not the custom of the Sheffield Assay Office to record an exact replica of the date letter selected for each year, it has been necessary to ascertain the earlier examples from existing specimens of old silver plate.

The list of date letters with the various shields, crowns, etc., have been reproduced mainly from articles in the author's possession. Upwards of twenty years have been spent in collecting and—with the help of the Assay Master—assigning them correctly. Indebtedness has also to be acknowledged to Messrs. Crichton Bros., of London, for allowing access to their record of marks found on antique silver made in Sheffield.

SPECIMENS OF ANTIQUE SILVER ARTICLES MANUFACTURED IN SHEFFIELD, FROM
THE AUTHOR'S COLLECTION.



Salt Cellar, by R. Morton & Co., 1775.



Sugar Basin, by J. Hoyland & Co., 1774.



Salt Cellar, by T. Fox & Co., 1784.

THE DATE LETTERS TO BE FOUND ON SILVER MANUFACTURED IN SHEFFIELD,
ARRANGED IN CHRONOLOGICAL ORDER.

YEAR.	Standard Mark.	Mark of Origin.	Date Letters.	Duty Mark.	Date Letters with Crowns.	YEAR.	Standard Mark.	Mark of Origin.	Date Letters.	Duty Mark.	Date Letters with Crowns.
1773						1798					
1774						1799					
1775						1800					
1776						1801					
1777						1802					
1778						1803					
1779						1804					
* 1780						1805					
1781						1806					
1782						1807					
1783						1808					
† 1784						1809					
1785						1810					
‡ 1786						1811					
1787						1812					
1788						1813					
1789						1814					
1790						1815					
1791						1816					
1792						1817					
1793						1818					
1794						1819					
1795						1820					
1796						1821					
§ 1797						1822					

* First year in which crown and date letter were struck in one shield (for use on small articles).
 † This year a duty of 6d. per oz. was imposed on silver, and an intaglio head was struck. In the earlier part of the year no head is found.
 ‡ The intaglio head is found for the first 6 months of this year also.
 § From July 15th, in this year, the King's Head was duplicated, owing to the duty being doubled. The duplication was continued for about 9 months.
 || In 1815 the crown was stamped upside down under date letter, for the five following years over date letter.

YEAR.	Standard Mark.	Mark of Origin.	Date Letters.	Duty Mark.	Date Letters with Crowns.	YEAR.	Standard Mark.	Mark of Origin.	Date Letters.	Duty Mark.	Date Letters with Crowns.
1823			U			1848			E		
1824			a			1849	''	''	F	''	
1825			b			1850	''	''	G	''	
1826			c			1851	''	''	H	''	
1827			d			1852	''	''	I	''	
1828			e			1853	''	''	K	''	
1829			f			1854	''	''	L	''	
1830			g			1855	''	''	M	''	
1831			h			1856	''	''	N	''	
1832			k			1857	''	''	O	''	
1833			l			1858	''	''	P	''	
1834			m			1859	''	''	R	''	
1835			p			1860	''	''	S	''	
1836			q			1861	''	''	T	''	
1837			r			1862	''	''	U	''	
1838			s			1863	''	''	V	''	
1839			t			1864	''	''	W	''	
1840			u			1865	''	''	X	''	
1841			v			1866	''	''	Y	''	
1842			x			1867	''	''	Z	''	
1843			z			1868	''	''	A	''	
1844			A			1869	''	''	B	''	
1845			B			1870	''	''	C	''	
1846			C			1871	''	''	D	''	
1847			D			1872	''	''	E	''	

YEAR.	Standard Mark.	Mark of Origin.	Date Letters.	Duty Mark.	YEAR.	Mark of Origin.	Standard Mark.	Date Letters.
1873			F		1891			Y
1874	''	''	G	''	1892	''	''	Z
1875	''	''	H	''	1893	''	''	a
1876	''	''	J	''	1894	''	''	b
1877	''	''	K	''	1895	''	''	c
1878	''	''	L	''	1896	''	''	d
1879	''	''	M	''	1897	''	''	e
1880	''	''	N	''	1898	''	''	f
1881	''	''	O	''	1899	''	''	g
1882	''	''	P	''	1900	''	''	h
1883	''	''	Q	''	1901	''	''	i
1884	''	''	R	''	1902	''	''	k
1885	''	''	S	''	1903	''	''	l
1886	''	''	T	''	1904	''	''	m
1887	''	''	U	''	1905	''	''	n
1888	''	''	V	''	1906	''	''	o
1889	''	''	W	''	1907	''	''	p
* 1890	''	''	X	''	1908	''	''	q
					1909	''	''	r
					1910	''	''	s
					1911	''	''	t
					1912	''	''	u

* The duty was taken off silver in this year. For about the first 4 months the Queen's head is found.





THE SHEFFIELD SILVERSMITHS' MARKS.

The main difference to be observed between the marks that the Old Sheffield manufacturers registered for plated articles and those for sterling silver goods, is that in the former case the full name with a device was struck, whilst in the latter initials (and occasionally only names) were used.



In the earliest days of the London silver industry the initial marks used by the makers were almost invariably accompanied by some form of device.



Possibly the passing of the Sheffield Assay Office Acts of 1773 and 1784 may have influenced in some degree the London silversmiths, as later than the year 1773 we find that the using of a device by them on silver goods had almost entirely ceased. From 1773 until 1854, manufacturers of silver within a radius of 20 miles of Sheffield were not allowed to assay their goods outside the town under pain of punishment. All this was altered in the year 1854 under 17 and 18 Vict., cap. 96.

A noticeable feature concerning the marks used by the Sheffield silversmiths is the variety of forms of punches they used without registration. In some cases these are quite untraceable at the Sheffield Assay Office.

John Younge & Co., who registered in 1779, struck at this period   and . In 1788 the same firm, the name changed to John Younge & Sons, re-register  and again in 1811, then described as S. & C. Younge .

All these punches are duly recorded, but lead to some confusion when attempting to trace the name of the firm by these initials.

John and Thomas Settle, who register in 1815, sometimes marked goods with the punch  and at other times , the same firm registering twice in the one year. This form of registration was of frequent occurrence in Sheffield, and so far cannot be satisfactorily explained. A suggestion that various classes of goods were reserved for the different marks has had to be negatived by the finding of duplicate silver articles made by the same firm but with their different devices thereon.

The firm of Battie, Howard & Hawksworth, who register the mark  in 1815, also used the punch .

To account for some of the irregularities in marking it seems probable that, when in the olden days there was a change of partnership, firms did not always consider it incumbent on them to notify the Assay Master to this effect or advise him that a new member of a firm had been admitted as a silversmith, and that the initials would in future be altered. Or more

probably if this was done, the Assay Master neglected to record this alteration in his books. In cases where firms were well known, he might perhaps have thought that any modification or fresh mark was unnecessary.

It is possible that some of these mistakes were due to the carelessness of the mark cutter and having for a time escaped the notice of both the firm and the Assay Master it was not thought advisable to alter the punches. In other cases where there is a total absence of anything recorded at the Assay Office corresponding with the initials found, we must look to over-marking by London silversmiths as an explanation. The following initials are not unfrequently to be found on Sheffield hall marked silver candlesticks manufactured towards the end of the 18th century  These marks were never registered at the local assay office. The first two punches would probably be used by "Daniel Smith and Robert Sharp," of London (an instance of whose over-marking of a Sheffield-made silver candlestick has previously been referred to on page 190). The latter mark may in all probability be attributed to "Thomas Daniell," also a London silversmith.

It must be admitted, however, that none of the foregoing suggestions seems to be entirely satisfactory, nor do they do very much to clear up the mystery associated with this marking. As with other irregularities that have previously been pointed out there is no doubt that a century or more ago it was not found necessary to keep as strict a supervision over matters concerning the assaying of silver as it is to-day. The great influx of registrations at the local office and the resulting necessity for stricter supervision have perhaps been the means of bringing about the greatly increased attention to minor details that is now customary at the Sheffield Assay Office.

Although absolute accuracy may not have been attained in assigning the initial punches to the several makers, great care has been taken to identify them correctly.

The following list of makers of silver goods who registered a mark in Sheffield commences with the year 1773 and terminates in 1869.



























To reproduce any later registrations is unnecessary, because silversmiths established in Sheffield subsequent to the year 1869 do not come within the scope of this volume. It would moreover be misleading, because the names registered during recent years are no indication of actual manufacturers. Retailers have become insistent on having their own initials—

not those of the makers—punched on the articles they sell. Hence the names of many individuals resident in Scotland, Ireland and Wales, as well as in most of the larger cities of England, are mingled in the registrations at the Sheffield Assay Office with those of local silversmiths.

LIST OF MAKERS OF ANTIQUE SILVER WHO REGISTERED AT THE SHEFFIELD ASSAY OFFICE, WITH MARKS TAKEN FROM ARTICLES THEY MADE.

Name of Firm.	Makers' Marks.	Date.	Location.
Ashforth G. & Co.		1773	Sheffield, Holy Street
Birks W. & Co.		1773	Do. Pincin Lane
Fenton M., R. Creswick & Co.	 	1773	Do. Mulberry Street
Hoyland J. & Co.	 	1773	Do. Union Street
Hancock W. & J. Rowbotham	 	1773	Do. Norfolk Street
Law T.	 	1773	Do. Norfolk Street
Littlewood John		1773	Do. Westbar Green
Littlewood Jonathan		1773	Do. Westbar Green
Morton R.		1773	Do. Fargate
Morton R. & Co.	 	1773	Do. Brinsworth Orchard
Marsden W. & Co.		1773	Do. Norfolk Street
Margrave J. & Co.		1773	Do. Townhead Cross
Proctor C. & L.		1773	Do. Milk Street
Roberts S.		1773	Do. Cheney Square
Roberts S. & Co.		1773	Do. Brinsworth Orchard
Trickett R.		1773	Do. Far Field
Tudor H. & T. Leader		1773	Do. Sycamore Hill

Name of Firm.	Makers' Marks.	Date.	Location.
Winter J. & Co.		1773	Sheffield, High Street
Wilson J.		1773	Do. Highfields
Cosins I.		1774	Do. High Street
Greaves S. & Co.		1774	Do. Norfolk Street
Holy T. & W. Newbold		1774	Do. West Bar
Ibberson J.		1774	Do. Gibraltar Street
Justice P.		1774	Do. Spring Croft
Kippax R. & Co.	 	1774	Do. High Street
Marsden W.		1774	Do. Waingate
Rowbotham J. & Co.	 	1774	Do. Norfolk Street
Damant W.		1775	Do. Smithfield
Fox W.		1775	Do. West Bar
Henfrey J. & S.		1775	Do. Spring Street
Jervis J.		1775	Do. Pea Croft
Kelk C.		1775	Do. Spring Street
Mappin J. & Co.		1775	Do. Fargate
Mappin J.		1775	Do. Fargate
Smith J.		1775	Do. Lambert Croft
Smith W.		1775	Do. Coalpit Lane
Warburton S. & Co.	 	1775	Do. Bridgehouses
Holy D. & Co.		1776	Do. Norfolk Street
Hoyland T.		1776	Do. Pond Lane
Lamborn T.		1776	Do. Milk Street























Name of Firm.	Makers' Marks.	Date.	Location.
Rogers M.		1776	Sheffield, Holly Croft
Rowbotham J.		1776	Do. Norfolk Street
Watkinson J.		1776	Do. Silver Street
Allen T.		1777	Do. Bailey Street
Creswick Joseph		1777	Do. West Bar Green
Hoyland W. & Co.		1777	Do. Burgess Street
Shemeld J. & Co.		1777	Do. Arundel Street
Green J.		1778	Do. Holly Croft
Harrison J.		1778	Do. Holly Croft
Holy D. & Co.		1778	Do. Norfolk Street
Naylor & Settle		1778	Do. Coalpit Lane
Prior T.		1778	Do. Gibraltar Street
Ratcliffe T.		1778	Do. Red Croft
Tibbitts J.		1778	Do. Gibraltar Street
Winter J.		1778	Do. High Street
Blonk B.		1779	Do. Change Alley
Kemp J.		1779	Do. Norfolk Street
Madin & Trickett		1779	Do. Farfield
Younge J. & Co.	   	1779	Do. Union Street
Cadman D.		1780	Do. Coalpit Lane
Dickenson J.		1780	Gainsborough
Foster R.		1780	Sheffield, Pond Street
Kirkby Mary		1780	Do. Brinsworth Orchard

Name of Firm.	Makers' Marks.	Date.	Location.
Patten W.	W·P	1780	Sheffield, Silver Street
Morton R.	RM	1780	Do. Brinsworth Orchard
Settle T. & Co.	T·S&C^o	1780	Do. Brinsworth Orchard
Shaw T.	TS	1780	Do. Fig Street
Smith N. & Co.	NS&C^o	1780	Do. Waingate
Birks W. & Son	WB&S	1781	Do. Norfolk Street
Briddock G. & Co.	G·B&C^o	1781	Do. Lambert Croft
Dewsnap J.	I·D	1781	Do. Trinity Street
Deakin S., A. Kitchen & Co.	SDK&C^o DSK&C^o SD&C^o	1781	Do. Hollycroft
Hunter M. & J. Twig	H&T MH U·C^o	1781	Do. Cheney Square
Madin P. & R. Trickett	PM RT	1781	Do. Farfield
Morton R. & Co.	RM RM &C^o	1781	Do. Brinsworth Orchard
Roberts S. & Co.	SR&C^o JSR	1781	Do. Arundel Street
Shemeld, Parkin & Co.	S·P&C^o	1781	Do. Union Street
Settle T.	T·S	1781	Do. Union Street
Sutcliffe R. & A. Sporle	A·S RS LS	1781	Do. Smithfield
Sykes J. & D. & Co.	SYKES &C^o	1781	Do. Pinchin Lane
Withers B.	B·W	1781	Do. Cheney Square
Broddrick B.	B·B	1782	Do. Fargate
Cawton J.	I·C	1782	Do. Snig Hill
Colley T.	TC	1783	Do. Burgess Street
Green J.	IG	1783	Do. York Street
Jones J., H. Greenway & Co.	HG&C^o	1783	Do. Holly's Croft

Name of Firm.	Makers' Marks.	Date.	Location.
Love J. & Co.		1783	Sheffield, Scotland Street
Nowill J.		1783	Do. Copper Street
Parsons J. & Co.		1783	Do. Market Place
Staniforth J. & Co.		1783	Do. Arundel Street
Brittain G. & Co.		1784	Do. Arundel Street
Cooper J.		1784	Do. Sandspavers
Fox T. & Co.		1784	Do. Holly's Croft
Green W. & Co.		1784	Do. Pinchcroft Lane
Hawley G.		1784	Do. Hollys Croft
Kirkby S. & Co.		1784	Do. Pond Lane
Swift J. & Co.		1784	Do. Norfolk Street
Wild W. & Co.		1784	Do. Trinity Street
Darby W.		1785	Do. Pea Croft
Green J.		1785	Do. Sims Croft
Proctor L. & Co.		1785	Do. Milk Street
Seynor J.		1785	Do. Pea Croft
Bailey J.		1786	Do. West Bar
Dewsnap W.		1786	Do. Lambert Croft
Hague & Nowill		1786	Do. Meadow Street
Makin J.		1786	Do. Pickle
Micklethwaite J. & J. Hounsfild ...		1786	Do. Pond Hill
Nowill T.		1786	Do. Meadow Street
Roberts S. Junr., & Geo. Cadman & Co...		1786	Do. Norfolk Street

Name of Firm.	Makers' Marks.	Date.	Location.
Roberts John	LR	1786	Sheffield, Sykes Square
Roebuck C.	CR	1786	Do. Lambert Croft
Spooner J.	LS	1786	Do. Bailey Fields
Tricket R. & Co.	RT RT&C	1786	Do. Hill Foot
Barraclough J. & J. Rowbotham	LB	1787	Do. Scotland Street
Davidson L.	LD	1787	Do. Spring Croft
Marriott L.	LM	1787	Do. Coalpit Lane
Stafford & Newton	SN	1787	Do. Arundel Street
Barnard R.	RB	1788	Do. Furnace Hill
Borwick J.	JB	1788	Do. Lambert Croft
Cooper G.	GC	1788	Do. Pea Croft
Lindley J. & Co.	L&C	1788	Do. Spring Croft
Owen R. & Son	RO	1788	Do. West Bar
Spur P. & Son	PS	1788	Do. Church Lane
Urton W.	WU	1788	Do. Hall Street
Younge J. & Sons	Y&S	1788	Do. Union Street
Greaves T.	TG	1789	Do. Gibraltar Street
Jervis W.	WJ	1789	Do. White Croft
Travis Nathaniel	NT	1789	Do. White Croft
Wright J.	IW	1789	Do. Smithfield
Brownell L.	LB	1790	Do. Howard Street
Law John	LL	1790	Do. Howard Street
Nowill T.	TN	1790	Do. Norfolk Street





















Name of Firm.	Makers' Marks.	Date.	Location.
Rodgers T.	TR	1790	Sheffield, Brinsworth Orchard
Rollinson Dollif	D·R	1790	Do. Spring Gardens
Wilkinson J.	LW	1790	Do. Lambert Croft
Parkin T.	TP	1791	Do. Copper Street
Rhodes E.	ER	1791	Do. Wicker
Barnard R. & W. Hadfield	RB	1792	Do. Grindlegate
Brocklesby B.	BB	1792	Do. Castle Street
Loy R.	RL R·LOY	1792	Do. Baileyfield
Parkin J. & A. Wigham	IP	1792	Do. Carver Street
Proctor & Beilby	PB	1792	Do. Milk Street
Rotherham J.	IR	1792	Do. Spring Street
Saynor J. & S.	IS	1792	Do. Bank Street
Sporle Robert & Co.	R·S &C	1792	Do. Paradise Street
Sykes John & Co.	JOHN SYKES &C	1792	Do. Pinstone Street
Sykes D.	DENNIS SYKES	1792	Do. Pinstone Street
Watkinson Hannah	HW	1792	Do. Silver Street
Whitelock H. & Co	H·W&C	1792	Do. Broad Lane
Creswick Joseph	IC	1793	Do. Queen Street
Ellis J. & Co.	IE&C	1793	Do. Red Hill
Fox Saml. & Ann	FF	1793	Do. West Bar
Green J. & G. Hague	IG·GH	1793	Do. Sims Croft
Green J., Roberts, Moseley & Co....	IG&C	1793	Do. Market Place
Kirby, Waterhouse & Co.	KW&C	1793	Do. Backfield























Name of Firm.	Makers' Marks.	Date.	Location.
Marsh J.		1793	Sheffield, Park
Rowbotham J.		1793	Do. Whitecroft
Sharrow J. & Co.		1793	Do. Eyre Street
Smith, Knowles, Creswick & Co.		1793	Do. Arundel Street
Sporle E. & Co.		1793	Do. Hawley Croft
Watkinson Hannah & William Watson...		1793	Do. Silver Street
Wilson Joseph & Co... ..		1793	Do. Fargate
Dalton G.		1794	Do. Simscroft
Eadon G. & Co.		1795	Do. Hollis Croft
Gregory J. & Co.		1795	Do. West Street
Kay J. & Co.		1795	Do. Meadow Street
Moore J.		1795	Derby
Proctor C. & T. Beilby		1795	Sheffield, New Market Street
Sampson I.		1795	Do. Burgess Street
Watson Thomas, Fenton James & Thomas Bradbury		1795	Do. Methodist Meeting Yard
Watson John... ..		1795	Do. Furnace Hill
Goodwin E.		1796	Do. Park
Jessop W.		1796	Do. Howard Street
Kirkby S. & Co.		1796	Do. Backfield
Tucker W., James Fenton & Co.		1796	Do. Red Hill
Warris T. & Son		1796	Do. Church Lane
Goodman A., Gainsford & Co.		1797	Do. Hawley Croft
Gregory R. & Co.		1797	Do. Pond Lane



















Name of Firm.	Makers' Marks.	Date.	Location.
Leader Danl....	DL	1797	Sheffield, Surrey Street
Linley W.	W.L	1797	Do. Lambert Street
Tudor H. & S. Nicholson ...	HT&C^o	1797	Do. Arundel Street
Younge J. T. & Co.	YWC TY & C^o	1797	Do. Union Street
Blagden T.	TB	1798	Do. Nursery Walk
Blake H.	H.B	1798	Do. Queen Street
Hague G.	G.H	1798	Do. Sims Croft
Leader Thos. & Danl.	TL DL	1798	Do. Surrey Street
Makin J. & Co.	J.M & C^o	1798	Do. Hollis Croft
Middleton Jewesson & Co....	JM&C^o	1798	Do. Campo Lane
Peacock J. & G. Austin ...	JP	1798	Do. Pond Street
Rock Henry ...	R.R	1798	Do. Broad Lane
Barnard D., J. Settle & Co.	DB&C^o	1799	Do. Scotland Street
Fenton John & Co.	JF&C^o	1799	Do. Pea Croft
Hardy J.	H.H	1799	Do. Wicker
Hewitt H. & H. Rock ...	H.R	1799	Do. Norfolk Street
Hinchcliffe J.	H.H	1799	Do. Campo Lane
Shore J. & Co.	J.S&C^o	1799	Do. Sycamore Street
Smelle E.	ES	1799	Derby
Brailsforth A. & Co.	A.B	1800	Sheffield, Trippet Lane
Cooper G.	G.C	1800	Do. Broad Lane
Jewesson R.	R.J	1800	Do. Milk Street
Kirkby J.	IK	1800	Do. Lambert Street























Name of Firm.	Makers' Marks.	Date.	Location.
Nowill T.		1800	Sheffield, High Street
Battie G. & Bros.		1801	Do. Furnace Hill
Bennett S. & P. Spurr,		1801	Do. Arundel Street
Ellis J., P. Spurr & P. Cadman Junr. ...		1801	Do. Arundel Street
Goodman A. & Co.		1801	Do. Park
Harwood W. & Co.		1801	Do. Howard Street
Poynton T. & R. Flower		1801	Do. Pond Street
Cooper T.		1802	Derby
Rodgers T.		1802	Sheffield, Coalpit Lane
Settle John & W. Hatfield		1802	Do. Scotland Street
Coar H.		1803	Do. Carver Lane
Dewsnap J.		1803	Do. Arundel Street
Quixall J. & Co.		1803	Do. Pond Street
Kay J.		1804	Do. Meadow Street
Poynton J. & Co.		1804	Do. Scotland Street
Staniforth J.		1804	Do. Bridgehouses
Drabble J. & Co.		1805	Do. Eyre Street
Roberts J., S. Moseley & J. Settle ...		1805	Do. Market Place
Rodgers John & Co.		1805	Do. Pond Street
Coldwell W.		1806	Do. Howard Street
Polack B.		1807	Do. High Street
Blagden T. & Co.		1808	Do. White Rails, Bridgehouses
Clark M., J. Hall & C. Clark		1808	Do. South Street











Name of Firm.	Makers' Marks.	Date.	Location.
Gainsford Robert	RG	1808	Sheffield, Eyre Street
Kirkby J., J. Waterhouse, J. Hodgson ...	JK&C^o	1808	Do. Carver Street
Nixon T. & Co.	TN&C^o	1808	Do. Norfolk Lane
Sanson T.	TS	1808	Do. Norfolk Street
Sykes J. & Co.	J.S. &C^o	1808	Do. Pinstone Lane
Gregory, Wostenholme & Co.	GWC	1809	Do. Moor
Kirkby J.	FK	1809	Do. do.
Thompson & Barber	EB	1809	Do. Arundel Lane
Wostenholme G.	GW	1809	Do. Rockingham Street
Wright J. & G. Fairbairn	WJR	1809	Do. Park
Brammar J. & S. Horrabin... ..	BB	1810	Do. Holy Croft
Creswick Thos. & Jas.	TC	1810	Do. Porter Street
Furness, Poles & Turner	PT&C^o	1810	Do. Furnival Street
Kitchen T.	TK	1810	Chesterfield, Dog Hole
Needham C.	CN	1810	Sheffield, Wicker
Smith G., R. Tate, W. Nicholson & E. Hoult	ST NH	1810	Do. Arundel Street
Tucker W., J. Fenton, E. G. Machon ...	WTF&C^o	1810	Do. Norfolk Street
Wass R.	RW	1810	Do. High Street
Wardell & Kempson	W&K	1811	Birmingham
Younge S. & C. & Co.	SCY &C^o	1811	Sheffield, Union Street
Mearbeck S.	SM	1812	Do. Angel Street
Rodgers Jos. & Son... ..	J&R	1812	Do. Norfolk Street
Nowill Jos.	IN	1813	Do. High Street

Name of Firm.	Makers' Marks.	Date.	Location.
Roberts, Clayton & Co.		1813	Sheffield, Solly Street
Younge & Deakin		1813	Do. Union Street
Battie, Howard & Hawksworth		1815	Do. Charles Street
Settle Jno. & Thos.		1815	Do. Norfolk Street
Settle Thos. & John		1815	Do. Norfolk Street
Blackwell & Parkin		1816	Do. Hicks Lane
Blackwell W. & Co.		1816	Do. Hicks Lane
Crawshaw J.		1816	Do. High Street
Fenton, Allanson & Co.		1816	Do. Norfolk Street
Parkin W.		1817	Do. Flat Street
Proctor W.		1817	Do. Fruit Market
Wrangham W.		1817	Lincolnshire, Louth
Eyre J. & Co.		1818	Sheffield, Coalpit Lane
Hadfield A.		1818	Do. Pepper Alley
Kirkby, Waterhouse & Co.		1818	Do. Carver Street
Rooke B. & Son		1818	Do. Sycamore Street
Vaughan T.		1818	Do. Ladies' Walk, Moor
Best T.		1819	Do. Howard Street
Creswick T. J. & N.		1819	Do. Paternoster Row
Dewsnap P.		1819	Do. Carver Lane
Dodd G.		1819	Do. Portmahon
Bagshaw W.		1820	Do. Spring Street
Clayton T.		1820	Do. Solly Street

























Name of Firm.	Makers' Marks.	Date.	Location.
Etches J. M.		1820	Sheffield, Howard Street
Martin B.		1820	Do. Ladies' Walk, Moor
Morton F.		1820	Do. White Rails
Briggs J. & Co.		1821	Do. Button Lane
Castleton, Milner & Co.		1821	Do. Carver Lane
Kirkby S. & W.		1821	Do. High Street
Hunt A.		1822	Do. Bailey Lane
Kirkby J., Gregory & Co.		1822	Do. Carver Street
Taylor J.		1822	Do. Portmahon
Watson John & Son		1822	Do. Burgess Street
Waterhouse, Hodgson & Co.		1822	Do. Portobello Place
Webster, Danby & Co.		1822	Do. Lea Croft
Whip J. & J. Rose		1822	Do. Cross Burgess Street
Briggs William		1823	Do. Button Lane
Fearn J. & G.		1823	London
Hatfield A. & Sons		1823	Sheffield, Pepper Alley, Fargate
Rowlings B.		1823	Do.
Fenton, Danby & Webster		1824	Do. Howard Street
Hammond C....		1824	Do. Church Lane
Law Joseph		1824	Do.
Law J., Atkin & Oxley		1824	Do. Eyre Street
Tinker S.		1824	Leeds
Addy G. & Son		1825	Sheffield, Pea Croft

Name of Firm.	Makers' Marks.	Date.	Location.
Ashforth J., J. Cutts & T. Anderton ...		1825	Sheffield, Silver Street
Houlden J.		1825	Do. Top Pea Croft
Settle J. & T., Gunn & Co.		1825	Do. Norfolk Street
Nowill W. & J.		1825	Do. Meadow Street
Nowill J. & W.		1825	Do. Meadow Street
Ashforth & Harthorn		1826	Do. Silver Street
Champion T. & Son		1826	Do. High Street
Crawshaw A.		1826	Rotherham
Roberts S., Smith & Co.		1826	Sheffield, Eyre Street
Underdown, Wilkinson & Co.		1826	Do. Sycamore Street
Watson W. & T. Bradbury		1826	Do. Mulberry Street
Green, Bradbury & Firth		1828	Do. Burgess Street
Hardesty G.		1828	Do. Norfolk Lane
Hennell S.		1828	London
Picksley C. & Co.		1828	Sheffield, High Street
Atkin & Oxley		1829	Do. Eyre Street
Dixon J. & Son		1829	Do. Silver Street
Newton J. & Son		1829	Do. Sharrow Moor
Smith J. & Son	 	1829	Do. Coalpit Lane
Burbury J.		1830	Do. Union Lane
Hardy, Bell & Co.		1831	Do. Union Lane
Hounsfield B.		1831	Do. Pond Lane























Name of Firm.	Makers' Marks.	Date.	Location.
Wilkinson H. & Co.		1831	Sheffield, Norfolk Street
Wilkinson & Roberts	W&R	1831	Do. Low Street, Park
Allanson W. & Co.		1832	Do. Norfolk Street
Bradbury Thos. & Sons		1832	Do. Arundel Street
Creswick T. J. & N.		1832	Do. Paternoster Row
Kitchen, Walker & Curr		1832	Do. Union Street
Watson Wm. & Co.		1832	Do. Arundel Street
Dawson H., Wilkinson & Co.		1833	Do. Sycamore Street
Harrison J. & Co.		1833	Do. Norfolk Lane
Hawksworth, Eyre & Co.		1833	Do. White Rails
Mappin Joseph & Son		1833	Do. Pepper Alley
Sansom & Harwood... ..		1833	Do. Norfolk Lane
Stokes G.		1833	Do. Moor
Hibbert G.		1834	Do. Mulberry Street
Thorpe, Glossop & Middleton		1834	Do. Carver Street
Dyson A.		1835	Do. Charles Street
Harwood S.		1835	Do. Highfield
Howard & Hawksworth		1835	Do. Hartshead
Kitchen & Walker		1835	Do. Burgess Street
Leonard P.		1835	Manchester, Salford
Sansom W.		1835	Sheffield, Union Street
Hardy T.		1836	Do. Union Lane
Hutton W.		1836	Do. South Street, Moor





















Name of Firm.	Makers' Marks.	Date.	Location.
Walker S. & Co.		1836	Sheffield, Burgess Street
Waterhouse John, E Hatfield & Co. ...		1836	Do. Portobello Place
Younge C. F.		1836	Do. High Street
Duke H.		1837	Do. Division Street
Hutchinson W. & H.		1837	Do. Norfolk Street
Carter W.		1839	Do. New Church Street
Simmons I.		1839	Manchester, St. Ann's Square
Lee & Middleton		1840	Sheffield, Mulberry Street
Lowe T. P.		1840	Do. Charles Street
Walker, Knowles & Co.		1840	Do. Burgess Street
Atkin Henry		1841	Do. Howard Street
Bradley E.		1841	Do. Arundel Street
Gilbert J.		1841	Birmingham, Ryland Street
Oxley John		1841	Sheffield, Charles Street
Cutts J. P.		1842	Do. Division Street
Waterhouse George & Co.		1842	Do. Carver Street
Bell J. & J.		1843	Do. South Street, Moor
Osborn & Elliott		1843	Do.
Rodgers Joseph & Son		1843	Do. Norfolk Street
Badger, Worrall & Armitage		1844	Do. Shales Moor
Boardman C.		1844	Do. Pond Street
Eaton T. W.		1844	Do. Radford Street
Harrison J.		1844	Do. Scotland Street









Name of Firm.	Makers' Marks.	Date.	Location.
Roberts J.		1844	Sheffield, Low Street, Park
Thompson & Brown		1844	Do. Eyre Lane
Roberts & Slater		1845	Do. Furnival Street
Freeman T.		1845	Do. South Street, Moor
Green J.		1846	Do. Fargate
Martin, Bros. & Co.		1846	Do. Division Street
Padley, Parkin & Co.		1846	Do. Watson Walk
Smith Josephus		1846	Do. Moor
Ward George		1846	Do. Exchange Street
Badger T.		1847	Do. Shalesmoor
Roberts & Hall		1847	Do. Park
Mappin & Son		1848	Do. Norfolk Street
Needham J.		1848	Do. Jehu Lane
Deakin G. & Co.		1849	Do. Eyre Street
Harrison Bros. & Howson	 	1849	Do. Norfolk Street
Wolstenholme J.		1850	Do. Broad Street, Park
Royle T.		1851	Do. Union Lane
Creswick T. J. & N.		1852	Do. Paternoster Row
Wilkinson H. & Co.		1852	Do. Norfolk Street
Atkin Bros.		1853	Do. Truro Works
Creswick T. J. & N.		1853	Do. Paternoster Row
Sansom & Davenport		1853	Do. Rockingham Street
Turner Thomas		1853	Do. Suffolk Works, Suffolk-rd.

Name of Firm.	Makers' Marks.	Date.	Location.
Archer, Machin & Marsh		1854	Sheffield, Fargate
Bell John		1854	Do. Stoker Cottage, near Cemetery
Bell Jonathan		1854	Do. South Street, Moor
Cowlishaw J. Y.		1854	Do. Market Street
Fenton James		1854	Birmingham, Gt. Hampton Street
Martin, Hall & Co.		1854	Sheffield, Shrewsbury Works
Archer & Co.		1855	Do. Fargate
Biggin John	 	1855	Do. Mulberry Street
Lockwood Bros.		1855	Do. Arundel Street
Marples T.		1855	Do. Arundel Street
Rhodes Bros.... ..		1855	Do. Mulberry Street
Stratford W. & H.		1855	Do. Snrrey Street
Fenton J. F.		1856	Do. Cadman Lane
Hawksley G. & Co.		1856	Do. Charlotte Street
Hukin & Fenton		1856	Do. Cadman Lane
Mappin Joseph & Bros.		1856	Do. Bakers Hill
Sansom & Creswick		1856	Do. Rockingham Street
Stacey, Henry & Horton		1856	Do. Norfolk Street
Fenton & Anderton		1857	Do.
Harrison W. W. & Co.		1857	Do. Fargate
Hutton W. & Son		1857	Do. High Street
Padley, Staniforth & Co.		1857	Do. Hartshead
Timm F. E.		1857	Do. Holy Croft

Name of Firm.	Makers' Marks.	Date.	Location.
Aston T. & Son		1858	Birmingham, Regent Place
Bradbury T. & Son... ..		1858	Sheffield, Arundel Street
Creswick & Co.		1858	Do. Paternoster Row
Hawksley G.		1858	Do. Charlotte Street
North J.		1858	Do. South Street, Moor
Rodgers Jos. & Sons		1858	Do. Norfolk Street
Sissons W. & G.		1858	Do. Eyre Street
Ward W. & S.		1858	Manchester, St. Mary's Gate
Wostenholme W. F.	W.F.W	1858	Sheffield Broad Street, Park
Brown & Clark		1859	Birmingham, Richard Street
Elkington, Mason & Co.		1859	Birmingham, Newhall Street
Mappin Bros.		1859	Sheffield, Queen's Works
Roberts & Briggs		1859	Do. Furnival Street
Slater, Son & Horton		1859	Do. Norfolk Street
Teasdel G.		1859	London, Hatton Garden, Holborn
White & Johnstone		1859	Sheffield, North Street
Fenton Bros.		1860	Do. Norfolk Lane
Knowles J. & Son		1860	Do. Burgess Street
Mappin & Co.		1860	Do. Royal Cutlery Works, Pond Hill
Edwards George		1861	Glasgow Gordon Street
Harrison W. W. & Co.		1861	Sheffield, Montgomery Works, Fargate
Mackay & Chisholm		1861	Edinburgh, North Bridge

Name of Firm.	Makers' Marks.	Date.	Location.
Pryor, Tyzack & Co.		1861	Sheffield, Division Street
Skidmore W.		1861	Do. Enema Works, Cemetery Road,
Unite G.		1861	Birmingham, Caroline Street
Chesterman Jas. & Co.		1862	Sheffield, Bow Works, Nursery Street
Slack Bros.		1862	Do. Leicester Works
Walker & Hall		1862	Do. Howard Street
Bradbury T. & Sons		1863	Do. Arundel Street
Briddon Bros.		1863	Do. Victoria Plate Works, Eyre Lane and Arundel Street
Creswick & Co.		1863	Sheffield, Sycamore Street
Levesley Bros.		1863	Do. Central Works, West St.
Martin, Hall & Co.		1863	Do. Shrewsbury Works, Broad Street, Park
Beardshaw A. J. & Co		1864	Do. Mulberry Street
Bright S. & Co.		1864	Do. St. James' Street
Brookes & Crookes		1864	Do. Atlantic Works, St. Phillip's Road
Hawksley G. & Co.		1864	Do. Charlotte Street
Mappin, Webb & Co.		1864	Do. Eyre Street
Robinson & Co.		1864	Do. Eyre Street
Roberts & Belk		1864	Do. Furnival Works
Towndrow Bros.		1864	Do. South Street, Moor
Mammatt, Buxton & Co.		1865	Do. Arundel Plate Works, Eyre Street
Mappin, Webb & Co.		1865	Do. Eyre Street
Turner T. & Co.		1865	Do. Suffolk Road

Name of Firm.	Makers' Marks.	Date.	Location.
Dodge W. & M.		1866	Manchester, Market Place
Harrison J. & Co.		1866	Sheffield, Norfolk Works, Scotland Street
Harrison W. W. & Co.		1866	Do. Montgomery Works, Fargate
Hutton W. & Sons		1866	Do. High Street
Parkin & Marshall		1866	Do. Furnival Street
White, Henderson & Co.		1866	Do. Elcho Works, Burgess St.
Beal M.		1867	Do. Market Place
Bradbury T. & Sons		1867	Do. Arundel Street
Briddon Bros.		1867	Do. Victoria Works, Eyre-lane
Dixon J. & Sons		1867	Do. Cornish Place
Ellis T.		1867	Plymouth, Old Town Street
Gallimore W. & Co.		1867	Sheffield, Arundel Street
Hawksworth, Eyre & Co.		1867	Do. Nursery Street
Makin E. J.		1867	Do. Charlotte Street
Mappin Bros.		1867	Do. Queen's Cutlery Works
Roberts & Belk		1867	Do. Furnival Works
Round J. & Son		1867	Do. Tudor Works
Slater J. & Son		1867	Do. Norfolk Street
Brearley W.		1868	Do. Carver Street
Fenton Bros.		1868	Do. Earl Street

Name of Firm.	Makers' Marks.	Date.	Location.
Levesley Bros.		1868	Sheffield, Central Works, West St.
Thompson J.	 	1868	Do. Soho Place, Napier St.
Walker & Hall		1868	Do. Howard Street
Beardshaw A. & Co.		1869	Do. Victoria Street
Hawksworth, Eyre & Co.	  	1869	Do. Nursery Street
Morton W.		1869	Do. Commercial Street

EXPLANATORY NOTE.

Attention is called to the occasional discrepancy in the spelling of the same surnames on preceding pages; this is owing to the fact that the names of firms have been taken from a variety of sources. For instance, the surname "Sansom"—different members of which family manufactured Sheffield Plate, silver, and silver cutlery—was at times spelt "Sanson." In the Sheffield Assay Office Registers the spelling is uniform, "Sansom." The surname "Kirkby" is sometimes found spelt "Kirby;" instances of this occur in the Sheffield Assay Office Silversmiths' Register.

In last paragraph on page 464 the second half of line 13 should read, "from July 1815 to July 1820."

PART XII.

THE BRITANNIA METAL INDUSTRY.

INVENTION OF BRITANNIA METAL.

The establishment of the silver plate trade of Sheffield was not the sole benefit conferred upon the town by Thomas Boulsover's invention. The history of inventions largely affecting the prosperity of communities is full of incidents; a notable one is that, when Boulsover was perfecting the methods which established the silver plate trade, Benjamin Huntsman, close at hand, was working out the details of that process of casting steel in crucibles which has played an even greater part than Boulsover's discovery in the fortunes of the same town. Huntsman took up his abode in Sheffield in 1742. After experimenting for long years, he perfected his process, and by 1772 his cast steel making, with its immense potentialities, was in full swing. Incidentally, from this industry, there was developed a vigorous off-shoot, so closely allied to its greater parent and playing so large a part in metal ware for domestic use as to demand special notice in this volume. What plated ware did for those not wealthy enough to furnish their tables with sterling silver, Britannia metal did for the classes unable to afford silvered copper; and the household requisites now brought within their reach were made of a material far more serviceable than the once predominant pewter. Ingenious mechanics, accustomed to the manufacture of fused plate, were quick to realise the possibilities of the new metal placed at their disposal by the shrewdness of an unfortunate discoverer.

About the year 1769 is the date usually, though rather vaguely, assigned as marking the origin of Britannia, or, as it was at first called, White Metal. This consists mainly of tin with an admixture of antimony and a little copper. Its appearance on the market must have been somewhat later than 1769, as there is no mention of it, or of James Vickers, the first to give it commercial value, in the Directory of 1774. In 1787 Vickers was utilising it for measures, teapots, castor frames, salts, spoons, &c., and a dozen or more firms were at the same time entered as "makers of White Metal and metal-framed knives." The earliest note of the change of name from White to Britannia Metal is found in the 1797 Directory; in that, James Vickers and one competitor (Richard Constantine) are given as White Metal Manufacturers. Froggatt, Couldwell and Lean appear as "Manufacturers of Britannia Metal Goods, and Silver Platers and factors, Eyre Street."

“White Metal and metal-framed knives” has in that book ceased to be a trade description, the only approach to it being “Jervis William, Bath and White Metal Cutler, White Croft.” In 1817, James Vickers’ son and successor, John, though still calling himself “White Metal Manufacturer,” designated his works “Britannia Place,” and was classified with others under the title “Britannia Metal Manufacturers.”

Mr. Charles Dixon’s notes (elsewhere referred to on the subject of fused plated ware) contain the following quaint references to the origin of the White or Britannia Metal :—

“I have heard it said that Mr. Nathaniel Gower* was the first person who began this trade, but I differ in opinion from that, and family circumstances have occurred which very much strengthen my argument. Mr. Gower was an early manufacturer and a very respectable one for the trade in its infancy ; but Mr. James Vickers, late of Garden Street, was the first person who began manufacturing articles in the white-metal trade in Sheffield.

About the year 1769 a person was very ill and James visited him. This man was in possession of the receipt how to make white-metal. James told him he would give him 5s. for the receipt, and he accepted the offer. James tried the receipt and found the metal was a very good colour. He then got some spoon moulds and began casting spoons, and getting them finished well he had a tolerable sale for them as far as his trade extended. He then got moulds for vegetable forks, and these made a variety for the market.

My father was visiting in a friendly manner one night with him, and he says, ‘Well, Charles, if I had but £10 I would get up a stock of goods and go to Lunnun with them.’ My father lent him the money. A short time after when in conversation he says, ‘Well, Charles, I thought if I was in possession of £10 I could have done anything, but now I find myself as fast as ever I was.’ My father says, ‘Well, James, I can lend thee another £10.’ He did so. James went to London and his journey was successful, he selling his articles and getting orders for more than he could find materials for to manufacture them with. He kept the money until his return from the next journey, when he paid my father, and he then began making different kinds of articles in the trade—tobacco boxes, beakers, tea pots, sugars, creams, etc.

It is generally stated that Mr. Gower was the first to commence this business, in 1773, but Mr. Vickers had begun a few years before in partnership with Mr. Smith.”

In the early days attempts were made to plate Britannia metal with silver by a method distinctly ingenious. A layer of “fine” silver having been rolled out to the required thickness, it was stretched on an even surface and well heated ; upon it the Britannia-metal was then poured in a hot, liquid condition. After it had cooled and picked up the thin layer of silver, the two were rolled down together to the required thickness for manipulation. A few articles made in this metal plated with silver and manufactured

* Obit. 30/9/1813, aged 83, and referred to in the *Sheffield Mercury* of that date as “The Father of the White Metal trade.”

in the old Sheffield plating days by Kirkby, Smith & Co., are still to be found, but the material was soon abandoned, for it presented too many difficulties in the making-up process, and it cannot be traced that any of the other manufacturers of that day even gave it a trial.

One of the firms most noted for the manufacture of Britannia metal from an early time to the present day is James Dixon & Sons. It was founded by James Dixon in the year 1804. At first trading as Dixon & Smith, in Silver Street, he confined his attention exclusively to Britannia metal wares; but, later, mills for rolling silver plate were established in Cornish Place, whither the whole business was ultimately transferred. About 1830 the firm, now become Dixon & Son, added Sheffield plated wares to their manufactures, so that whereas up to the year 1828 in Directories they had been described as "Britannia metal makers and silver plated and metal rollers," in 1833 they were entered as "James Dixon & Sons, manufacturers of silver, silver-plated and Britannia metal goods, copper powder flasks, shot belts, &c., and silver and metal rollers." The following comments of the jurors concerning J. Dixon & Sons' exhibits of Britannia metal goods at the 1851 Exhibition will be read with interest: "These manufacturers have exhibited a collection of coffee and tea services made of Britannia metal, an imperfect imitation of silver, as are all the compounds used for this purpose; but the forms are as varied as they are well chosen, and might be very advantageously imitated for the same articles in silver; the workmanship is very good and the jury award the prize medal in consequence."

Probably no firm in Sheffield have ever made more goods of white metal. The style of the articles belonging to the earlier period of their existence are in good taste and also show originality of design. To-day their establishment is perhaps the largest of its kind in the trade, whilst their goods, bearing the mark, the Trumpet with Banner, are to be met with everywhere in Europe and our colonies. 

The ingredients used in the making of the ordinary Britannia metal are roughly as follows:—210 parts of tin, 12 parts of antimony, 4 parts of copper. But these proportions vary very much, for the manufacturer carefully regulated his material according to the specific purposes of particular articles. (Lead is most carefully excluded in the manufacture of Britannia metal.)





Mr. Lennox Dixon, of the firm of J. Dixon & Sons, states that in mixing their metal the following ingredients are used by his firm:—

448 parts of tin, 20 to 60 parts of antimony, 5 parts of copper.

The price of tin being usually 10 to 12 times higher than that of lead, the melting value of Britannia metal is relatively much higher than that of common pewter; the reason for the decline of the pewterer's craft has no doubt been the invention of the better coloured and more serviceable Britannia metal. Nowadays, before being placed on the market, almost all B.M. goods are subjected to the process of electro-plating.

There may be seen in antique shops to-day large numbers of Sheffield-made articles, very pleasing in their design, described as "antique pewter," but composed of white metal; their manufacture dates from about the year 1787, they are often marked with the name Vickers, while later pieces more frequently bear Dixon's stamp.

The following are a few of the marks which were struck by the more prominent Britannia metalsmiths of Sheffield, with approximate dates of their earliest use:—

1787	Mark used by	James Vickers on Britannia Metal	..		
1797	Do.	Kirkby, Smith & Co.	do.	..	
1800	Do.	William Holdsworth	do.	..	
1804	Do.	Dixon & Smith	do.	..	DIXON
1830	Do.	J. Dixon & Son	do.	..	DIXON & SON
1833	Do.	J. Dixon & Sons	do.	..	JAMES DIXON & SONS BEST BRITANNIA METAL
1817	Do.	John Vickers	do.	..	
1821	Do.	W. Parkin	do.	..	PARKIN
1828	Do.	J. Wolstenholme	do.	..	J.WOLSTENHOLME.
1830	Do.	P. Ashberry	do.	..	
1837	Do.	E. Stacey	do.	..	E STACEY SUCCESSOR TO I.VICKERS BRITANNIA PLACE SHEFFIELD.

On the two following pages are reproduced specimens of antique Britannia metal. A few of these articles, notably the candlestick, have been copied by the makers directly from Sheffield Plate designs. The tea-pots, however, are distinctive and peculiar to the Britannia metal industry. Larger specimens of Britannia metal are sometimes found identical with the floral designs in vogue in Sheffield Plate between the years 1825 and 1850. These comprise entrée dishes, cake baskets, etc., made up from dies hitherto exclusively used for the manufacture of sterling silver and Sheffield Plate. This utilisation had become very general in the trade at the date of the great Exhibition, and the practice may, perhaps, explain the comments of the Jurors referred to on page 496.



B.M. Octagonal half-pint engraved Tea Caddy,
by Kirkby, Smith & Co. Author.
Date 1797.



B.M. Fluted and engraved 1-pint Tea Caddy,
Date 1787. by J. Vickers. Author.



B.M. Oblong full-sized Sugar Basin,
Date 1810. by J. Vickers. Author.



B.M. Pepper Pot, 3½ in. high,
by J. Vickers. Author.
Date 1790.



B.M. Mustard Pot,
by Dixon & Smith. Author.
Date 1823.



B.M. Oblong Small Cream Jug,
Date 1810. by J. Vickers. Author.

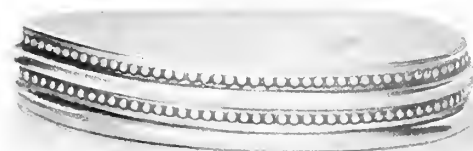

B.M. Snuff Box, with wood bottom,
Date 1795. by J. Vickers. Author.

ILLUSTRATIONS OF ANTIQUE BRITANNIA METAL ARTICLES.

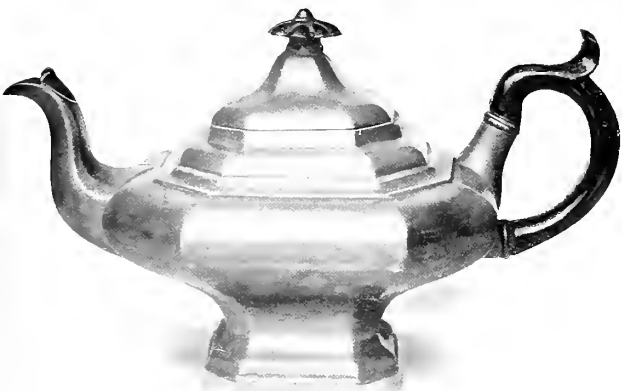

B.M. Octagonal 5-gill Teapot, by J Dixon & Son.
Date 1830. Author.



B.M. Salad Bowl, 6 $\frac{3}{4}$ in. diam., by Joseph Wolstenholme.
Date 1825. Author.



B.M. 10 $\frac{1}{2}$ in. Telescopic Candlestick, by W. Parkin.
Date 1825. Author.



B.M. Wine Strainer, by Dixon & Smith.
Date 1817. Author.



B.M. 1-gill Teapot, by J. Vickers.
Date 1828. Author.

BRITANNIA METAL AS DISTINCT FROM PEWTER.*

Writers on the subject of Pewter are apt to be misled by the latter day invention of "Britannia" or "White" metal. They illustrate as specimens of antique "pewter" articles that are obviously made of Britannia metal. The latter can, as a rule, be easily picked out by their characteristic construction. They also vary considerably in design from articles made by the Pewterers. Although the different materials bear great resemblance to each other after being in use for many years, old pewter has a more leaden appearance, due to the fact that it always contains a percentage of lead.

The chief distinction between Britannia metal and pewter is the complete absence of lead from the former and its essential presence in the latter. But the amount of the lead in pewter varies very much. In common pewter the proportion may be found amounting to 80 parts of lead to 20 parts of tin, with a slight admixture of copper, antimony and zinc. These are the ingredients as given in Watts's "Dictionary of Chemistry."† On the other hand, in other works on metallurgy the respective amounts of these elements are completely reversed—80 parts of tin to 20 or less parts of lead. These, with a slight addition of antimony and copper, approximated the alloy so closely to Britannia metal that the two can hardly be distinguished. No fixed rule was observed in the preparation of pewter, the ingredients being varied by the makers according to the quality required by the purchasers, or the adaptability of the articles to their uses.‡ Thus it was essential that table requisites, liable to contact with the sharp edge of a knife blade, or the sharp prongs of a fork, must needs be harder than vessels for holding liquids. In the earlier days, too, large, heavy so-called "pewter" meat dishes and plates were very frequently made from tin and temper, i.e., tin with an alloy known as "temper." The larger portions of this preparation consisted chiefly of copper and tin.

The brightness and polish that old pewter will take can scarcely be attributed to the silver contained therein, as there was less than 11 oz. of silver to a ton of lead. The silver added rigidity, and possibly, when argentiferous lead was used in old pewter, it may also have added to the hardness of the amalgam. Tin is nearest in whiteness to silver, but is too

* The writer is indebted to Professor L. T. O'Shea, of Sheffield University, for much help on technical matters in connection with this subject.

† Vol. iii., p. 535 (1882).

‡ So far no two articles of pewter by different makers analysed by the author have shown the same results.

crystalline a metal in its pure state to be entirely satisfactory for the manufacture of articles for domestic table ware. The alloy of lead and tin was less crystalline and approached the colour of silver as nearly as possible, though it was perhaps a little greyer.

There is little trace of the existence in Sheffield of Pewterers previous to the invention of fused plate.*

ORIGIN OF PEWTER WARE.

The interest taken in Pewter ware by collectors has very greatly increased of late years, especially since the decrease in its manufacture consequent on the introduction of Britannia or white metal, which has almost altogether supplanted it.

Possibly the manufacture of pewter ware was originally the outcome of the desire to have some metal vessels in daily use that, whilst resembling silver in appearance, would be far less costly.

The public are often surprised to find on antique pieces of pewter, Hall marks almost identical with those in use on solid silver goods, and in some instances have purchased such articles thinking they must be made of sterling silver.



Now this copying of the contemporary hall mark by the pewterers was a very old bone of contention between the Company of Goldsmiths and the Company of Pewterers of London, and dates back to Elizabethan times. In the reign of Charles I. definite steps were taken by the Goldsmiths' Hall to put an end to this practice, but all to no purpose. A petition to the Lords of the Council resulted in an admonition to the pewterers, who were bidden to observe the Hall regulations. Although they apparently had no defence to set up for their conduct, nor excuses to offer for copying the silver marks, they never ceased to reproduce them. It is difficult to understand why exemplary punishment was not meted out to those members of the Pewterers' Guild who were guilty of imitating these marks. From time to time cases would occur in which fines were imposed, but these instances were by no means frequent. The fact remains that pewterers continued to strike these silver hall marks, and that the penalties imposed on them for doing so seem quite out of proportion to the offences committed.

* In R. E. Leader's "Sheffield in the 18th century," James Hoole, "Pewterer," is recorded as tenant of the George Inn, Sheffield, in the year 1682.



INDEX

A

- "A.S.," Tray made by (ill.), 320.
- Acorn Device**, 435.
- Acts of Parliament**
1773—Provisions of Act, establishment of Assay Offices in Sheffield and Birmingham, etc., 426, 470.
Standard of silver and duty mark, 463.
1784—Regulations for marks on Old Sheffield Plate, 426.
- Adam Period**, Designs of, etc., 192.
Candlesticks (ill.), 222, 224, 225.
Dies for, 103.
Destruction of "Adam" dies, 59.
Draw handle (ill.), 388.
Jugs (ill.), 307, 308.
Soy frames, sale room values, 184.
Tea urn (ill.), 362.
- Adam, Robert**, Architect—Influence on design, 192.
Book of designs in Sir John Soane Museum, London, 192 *note*.
- Adams family** (Potters), 194.
William, 194—Portrait, 193.
Mounted Ware, 338 (ill.), 339, 340.
- Adams, Mr. Percy W. L.**, Wolstanton, Staffs., VIII., 338 *note*.
- Addy, G. & Son**—Mark for silver goods (1825), 484.
- "Alcomy," 16.
- Alfermann, Herr Felix**, Berlin, VIII., 158.
- Allanson, W. & Co.**—Mark for silver goods (1832), 486.
- Allen, John**, Birmingham—Glass supplied to M. Fenton & Co. and Watson & Bradbury, 68.
- Allen, T.**—Mark for silver goods (1777), 474.
- Allen, Thomas**—No marks used on plated goods, (1781), 443.
- Allgood, J.**—Plate mark (1812), 448.
- Allport, E.**—Plate mark (1812), 448.
Snuffers made by (ill.) 8.
- Altar Cruet**, French made, 275 (ill.), 168.
- Altona**, Sheffield Plate exported to, 159.
- America**, trade with, in Old Sheffield Plate, 156-8.
Cessation of trade, cause, etc., 58 *and note*.
- Amount of Old Sheffield Plate** to be found in Sheffield, 1.
- Amsterdam**, Old Sheffield Plate in, 159.
- Anthony, Michl. H. & Thos.**, Philadelphia—Customers of Watson & Bradbury (1815), 157.
- Antiquity of Practice of Plating**, 4.
- Antiquity of Specimens**
Test of, 175.
refer also to title Reproductions or "Fakes."
- Antwerp**, Old Sheffield Plate exported to, 159.

Apprentices

- Deed of Apprenticeship (1800), 53 (ill.), 54.
Period of Apprenticeship and subsequent training, 53.
- Archer & Co.**—Mark for silver goods (1855), 489.
- Archer, Machin & Marsh**—Mark for silver goods (1854), 489.
- "Argand Ami"—Wick-raising patent, 395.
- Arganda Lamp**, 395 and ill.
- Argentine**, *see* German Silver.
- Argyle gravy holders**, 203-4 (ill.), 203.
- Armour plating**—Origin of, Mr. J. D. Ellis's patent, 13 *note*.
- Ashberry, P.**—Marks for Britannia Metal (1830), 497.
- Ashforth & Harthorn**—Mark for silver goods (1826), 485.
- Ashforth, G., & Co., or Ashforth, Ellis & Co.** 31, 42, 60.
Articles made by (ill.), 207, 212, 263, 272, 288, 294, 312, 334, 353, 375, 392.
Marks
Cutlery (1774), 458.
Plated goods (before 1773), 441; (1781) No marks, 443; (1784), 444.
Silver goods (1773), 472.
Silver punch stamped on plated ware, 428.
Paris Branch in connection with Wedgwood's showroom, 194.
- Ashforth, J., J. Cutts & T. Anderton**—Mark for silver goods (1825), 485.
- Ashforth, William**, 42.
- Ashley**—Plate Mark (1816), 449.
- Askew, Henry**, of Nottingham, 146, 438.
Mark (1828), 450.
- Assay Office, Birmingham**—Establishment, 426.
- Assay Office, London**—William Hancock's complaints in 1773, 29.
- Assay Office, Sheffield**
Assay Masters (1773-1898), 464.
Establishment, 30, 426, 463.
Restrictions, etc., 30.
Guardians of, VI., VII.
Marks on Sheffield assayed silver, standard marks, marks of origin, date letters, duty marks (date letters with crowns), lists, etc., 463-493.
Carelessness prior to 1854, 465.
Crown stamped upside down (1815-9)—Pose, 464-5.
Date letters, 464-469.
List 467-9—Source of list, 466.
Duty marks, 464-469.
Double duty mark, 466.
Ireland, 466.
Method of striking, 465.
Mark of origin and date letter combined in one punch, 465.

Assay Office, Sheffield—Continued.

Marks—Continued.

Separate pieces attached to main body of article by hinges, etc.—Omission to strike, 465.

Size of marks in early times, 464.

Silversmiths' and cutlers' marks, 453-460, 473-493.

Residence (1774), 26.

Association of Sheffield Silversmiths—First Association, members, objects, rules, etc., 51.**Aston Hall, Chapel of, Birmingham**—First Electroplating Machine, 140.**Aston, T., & Son**—Mark for silver goods (1858), 490.**Atkin & Oxley**—Mark for silver goods (1829), 485.**Atkin Bros.**

Mark for silver goods (1853), 488.

Present representative of John Law & Sons, 34.

Atkin, Henry—Marks.

Plated goods (1833), 451.

Silver goods (1841), 487.

Attercliffe Glass House, 69.**Austria**, Marks from Tray manufactured in, 172.**Author's acknowledgments**, VI., VII., VIII.

B

Back to back method of strengthening mounts, 76-8 (ill.), 83.**Badger, T.**—Mark for silver goods (1847), 488.**Badger, Worrall & Armitage**—Mark for silver goods (1844), 487.**Bagshaw, W.**—Mark for silver goods (1820), 483.**Bailey, J.**—Mark for silver goods (1786), 476.**Bailey, Jas. S., New York**—Customer of Watson & Bradbury (1816), 157.**Baker, Mr. Hiatt**, Almondsbury, Gloucester, VII.**Balaine**—French maker, 161, 170.

Articles made by (ill.), 163, 166, 169.

Mark, 171.

Baldwin & Jones, Boston—Customers of Watson & Bradbury (1816), 157.**Ball, Black & Co.**, 158.**Ball Feet to Teapots**, 355.**Ball, Tompkins & Black**, 158.**Banister, W.**—Mark (1808), 447.**Banks, Chas., Charleston**—Customer of Watson & Bradbury (1800-1), 157.**Barber's Dish** (ill.), 391.**Barker, Mr. T. P.**, Four Oaks, Warwickshire, VIII.**Barlow, James**—Patent for improvements in Candlesticks, 247.**Barnard, D., J. Settle & Co.**—Mark for silver goods (1799), 480.**Barnard, R.**—Mark for silver goods (1788), 477.**Barnard, R., & W. Hadfield**—Mark for silver goods (1792), 478.**Barnett, Mr. S.**, Chester, VII.**Barraclough, J., & J. Rowbotham**—Mark for silver goods (1787), 477.**Barraclough, Mr. H.**, Leeds, VII.**Barraclough, Mr. J.**, Leeds, VII.**Barton, Erastus & Co.**, New York.

Customers of Watson & Bradbury (1821), 157
Firms descended from, 158.

Basker, C., & Son, Grantham, VIII.**Baskets for Cake, etc.**, see title *Cake, Fruit and Bread Baskets*.**Battie, G., & Bros.**—Mark for silver goods (1801), 481.**Battie, Howard & Hawksworth.**

Article made by (ill.), 258.

Mark for silver goods (1815), 470, 483.

Beakers (ill.), 351.**Beal, M.**—Mark for silver goods (1867), 492.**Beardshaw, A., & Co.**—Mark for silver goods (1869), 493.**Beardshaw, A. J., & Co.**—Mark for silver goods (1864), 491.**Beatson, Wm., & Co.**, Rotherham.—Glass supplied to M. Fenton & Co. and Watson & Bradbury, 67, 69.**Beaufort Arms Hotel, Monmouth**—Old Sheffield Plate in use, 56.**Beaver, M.**, Manchester, VIII.**Beldon & Hoyland or Beldon, Hoyland & Co.**, 38.

Marks

Cutlery (1787), 459.

Plated goods (1785), 445.

Beldon, G.—Mark (1809), 447.**Beldon, Joseph**, 38.**Belgium**, Old Sheffield Plate in, 159.**Belk, Mr. W. P.**, of Sheffield, VI.**Bell** (ill.), 389.**Bell Device**, 43, 78, 430, 431.**Bell, J. & J.**—Mark for silver goods (1843), 487.**Bell, John**—Mark for silver goods (1854), 489.**Bell, Jonathan**—Mark for silver goods (1854), 489.**Bennett, Mr. J. C.**, of the Sheffield Smelting Co., VII.**Bennett, S., & P. Spurr**—Mark for silver goods (1801), 481.**Benson, John Dudley**—Glass supplied to M. Fenton & Co. and Watson & Bradbury, 68.**Benzie, Mr. H. S.**, Cowes, VII.**Best & Wastidge**—Mark (1816), 449.**Best, H.**—Mark (1814), 448.**Best, T.**—Mark for silver goods (1819), 483.**Bethell, Mr. Alfred**, Newton Kyme, Tadcaster, VII.**Beverley Cathedral**—Lady Idonea Percy's Monument, 29.**Biggin, John**—Mark for silver goods (1855), 489.**Biggins** (ill.), 262.

Derivation of "biggins," 259.

Silver and Sheffield Plate biggins (ill.), 201.

Biggs, E. T., Maidenhead, VIII.**Billot, Mr. A. L.**, of Sheffield, VII.**Bingham, Henry**—Dublin dealer supplied by Watson & Bradbury (1804), 153.**Bingley, W.**—Mark (1787), 445.**Binns, A. & W., George Binns, Mrs. Ann Binns & Wm. Binns**—Dublin dealers supplied by Watson & Bradbury (1795-1813), 153.**Birch & Gaydon**, London, VIII.

- Birks, W., & Co.**—Marks.
Old silver cutlery, handles of (1773), 455.
Silver goods (1773), 472.
- Birks, W., & Son**—Marks.
Old silver cutlery, handles of (1781), 455.
Silver goods (1781), 475.
- Birks, William**, 433.
- Birks, William & John**—Cutlery Mark (1787), 459.
- Birks, Withers & Sykes**—Cutlery Mark (1774), 458.
- Birmingham.**
Act of 1773, establishment of Assay Office, 426.
Act of 1784, inclusion under, 426.
Attempts to rival Sheffield Plate manufacture, 29.
Climate, 51.
Close plating almost confined to Birmingham district, 145.
Electro-plate, introduction of, 140.
Inferior quality of plated goods—Extract from letter written in 1843, 41.
Makers of Old Sheffield Plate—Matthew Boulton, 47-50.
Number of platers registered at Sheffield Office—Explanation, 428.
Reproductions or "fakes," manufacture of, 174-5.
- Birmingham, Wm.**—Dublin dealer supplied by Watson & Bradbury (1804-7), 153.
- Bishop, Thomas**—Mark (1830), 451.
- Black, Starr & Frost**—Present day representatives of Erastus Barton & Co., 158.
- Blackford, Sydney**, Lynton, VIII.
- Blackwell & Parkin**—Mark for silver goods (1816), 483.
- Blackwell, W., & Co.**—Mark for silver goods (1816), 483.
- Blagden, Hodgson & Co.**, 59.
Articles made by (ill.), 269, 289.
Marks.
Plated goods (1821), 436, 450.
Silversmith's mark registered (1808), 437.
- Blagden, Thomas**, 437, *note*.
Silversmith's mark (1798), 437, 480.
- Blagden, T., & Co.**
Mark for silver goods (1808), 481.
Silver knob from plated teapot (ill.), 462.
- Blake, H.**—Mark for silver goods (1798), 480.
- Blake, Mr. Hamilton**, Edinburgh, VII.
- Blonk, B.**—Mark for silver goods (1779), 474.
- "Blue" or "Blood" stone, 132.
- Boardman, C.**—Mark for silver goods (1844), 487.
- Bolsterstone**, Glass House at, 69.
- Borders.**
Candlesticks, 215.
Salvers and trays (ill.), 76, 77.
Illustrations of various designs, 316-26.
Three methods of treatment (ill.), 83.
Silver borders on French plated goods, mark on, 170.
- Borwick, J.**—Mark for silver goods (1788), 477.
- Both sides of ingot, plating on**, *see* Double-side plating.
- Bottle Stands or Trays**, *see* Coasters.
- Bougie Boxes**, 198, 250 (ill.), 251.
- Bouilhet, Mons. Henri**, Paris, VIII.
- Boulenger & Cie**—French makers, 161.
Marks, 161, 171.
- Boulsover, Thomas**. Inventor of plating by fusion (Old Sheffield Plate), 25, 40.
Boxes made by, 19.
Bradbury, Thomas, & Sons' predecessors (M. Fenton & Co.), dealings with, 9 *note*, 16.
Button making, 14, 16, 17, 27.
Directory of 1774, description in, 15.
Dixon's, Charles, recollections of, 13-4.
Freedom, date of taking out, 27.
Fusion plating, invention of, 139.
Fame rightly belonging to Boulsover eclipsed by J. Hancock, 28.
Nature and occasion of discovery, 5, 9.
Premises in which discovery was made, tradition as to, 36.
Hancock's, Joseph, alleged apprenticeship with Boulsover, 26.
Longevity, 51.
Mark—None traced, 441.
Other businesses founded after discovery of plating by fusion, 10, 15.
Pegge's, Strelley, loan to, 14.
Portrait, 24.
Rolling metal for the trade, 10, 109.
Salver presented to his daughter in 1760, 25, 316 (ill.), 25.
Saw-making, new method of, 10.
Relics of enterprise, 10 (ill.), 3.
Spelling of name, 9 *note*, 14 *note*.
- Boulton & Fothergill**—Marks.
Before 1773, 49 and *note*, 441.
1781—No marks used, 443.
- Boulton & Smith**—Buckles (ill.), 23.
- Boulton, Matthew, or M. Boulton & Co. (or Boulton & Smith)**, of Birmingham, 43, 47-50.
Articles made by, illustrations, etc., 23, 62 *note*, 97, 203, 230, 236, 249, 252, 268, 270, 285, 287, 288, 312, 313, 321, 331, 364, 395.
Commemorative medal (ill.), 48.
Dies, dispersal of, 60.
Edges.
Hard soldered silver edges, 92 *note*.
Silver threaded edges, 82.
Factory (ill.), 49.
Disappearance, 50.
Later productions, number extant, etc., 430-1.
Longevity, 51.
Marks.
None used (1774 and 1777), 442.
Registered (1784), 49 and *note*, 430, 444.
Portrait, 48.
Quality of work, 50.
Sheffield, relations with, 47, 49.
Social relations, 50.
Standing of firm, 145.
Trade learnt at Sheffield, 145 and *note*, 421.
Trafalgar medal, 49.
Wedgwood and other potters, work for, 50, 194.
- Boulton, Matthew, Senr.**, of Birmingham, 47, 145.
- Boulton, Matthew, and Plate Co.**, 50.
- Bowker, Mr. T.**, Sheffield, VII.
- Bowls for Punch and Loving Cups**, 347 (ill.), 348, 351.
- Boxmaking** from fused plated metal.
"Faked" piece (ill.), 177.
French, manufacture ascribed to, 19.
Importance in early times, 17, 35.
Snuff and patch boxes, 19 (ill.), 20, 21.
- Boxwell, Ambrose**—Dublin dealer supplied by Watson & Bradbury (1795-1808), 153.
- "Bracket" Candlesticks, 198.

- Bradbury, Daniel**—Assay Master in 1773; 38, 464.
- Bradbury, James**—Cutlery Mark (1833), 460.
- Bradbury, Joseph**, 36.
- Bradbury, Joseph** (son of Thomas Bradbury, Junr.), 37.
- Bradbury, Messrs.**, VII.
- Bradbury, Miss**, VII.
- Bradbury, Nicholas**, 36.
- Bradbury, Sir Thomas**, Lord Mayor of London (1509), 36.
- Bradbury, Thomas**.
Biographical sketch, family, etc., 36-8.
Longevity, 51.
- Bradbury, Thomas, Junr.**, 37.
Apprenticeship deed, 53 (ill.), 54.
Masterpiece—Octagonal tea canister (ill.), 352.
- Bradbury, T., & Sons**.
American trade (1826-30), 156.
Articles made by (ill.), 213, 231, 257, 412, 419, 420, 421, 422, 424.
Boulsover's, T., firm, records of transactions with, 9 *note*.
Descent from Matthew Fenton & Co., 36-7.
Dies and tools owned in 1771, 60.
Illustrated designs from catalogues, the property of T. Bradbury & Sons, 90, 398-416.
Marks for silver goods (1832), 486; (1858), 490; (1863), 491; (1867), 492.
Predecessors, *see* Fenton, M., & Co.
Premises, 37.
Staff, VII.
- Bradley, E.**—Mark for silver goods (1841), 487.
- Bradley, Mr. T.**, VII.
- Bradshaw, J.**—Mark (1822), 450.
- Brailsforth, A., & Co.**—Mark for silver goods (1800), 480.
- Brammar, J., & S. Horrabin**—Mark for silver goods (1810), 482.
- Brass, use of**, by Sheffield platers, 79 *and note*.
- Bravo, Isaac, Altona**—Customer of Watson & Bradbury (1795-1805), 159.
- Bread Baskets**, *see* Cake and Fruit Baskets.
- Breakfast Dishes with Covers** (ill.), 267, 432.
Sale room values, 183.
- Brearley, W.**—Mark for silver goods (1868), 492.
- Briddock, G., & Co.**—Mark for silver goods (1781), 475.
- Briddon Bros.**—Marks for silver goods (1863), 491; (1867), 492.
- Briggs, J., & Co.**—Marks for silver goods (1821), 484.
- Briggs, William**—Marks, 430 *note*.
Plated goods (1823), 450.
Silver goods (1823), 484.
- Bright, Joseph**—Wages for die sinking, 61.
- Bright cut Engraving**, 86 and ill.
- Bright Plating**, Elkington & Radcliffe's secret, 140.
- Bright, S., & Co.**—Mark for silver goods (1864), 491.
- Britannia Metal or White Metal Industry**, V.
Date of invention and appearance on market, 494.
Designs (ill.), 498-9.
Pewterers' designs, difference from, 500.
Sheffield Plate and silver, extent to which designs were copied from, 497.
Dixon's, Charles, notes, 495.
- Britannia Metal**—*Continued*.
Dixon's, James, & Sons, business—Exhibits in 1851, etc., 496.
First makers—Erroneous assertion, 29.
Ingredients, 494, 496.
Melting value as compared with pewter, 497.
Name—Date of change from White to Britannia Metal, 494.
Pewter, extent of resemblance to, 500.
Plating.
Electro-plating, 497.
Method tried and abandoned by early makers, 495.
Roberts's, S., junr., patent, 43.
- Brittain, G., & Co.**—Mark for silver goods (1784), 476.
- Brittain, Wilkinson & Brownill**—Mark (1785), 445.
- Brocklesby, B.**—Mark for silver goods (1792), 478.
- Brodrick, B.**—Mark for silver goods (1782), 475.
- Brookes & Crookes**—Mark for silver goods (1864), 491.
- Brown & Clark**—Mark for silver goods (1859), 490.
- Brown, J., & Co.**, 13 *note*.
- Brown, late Sir J.**, 13 *note*.
- Brownell, L.**—Mark for silver goods (1790), 477.
- Brownhill, Maurice**, 17 *note*.
- Bruford & Son**, Exeter, VIII.
- Buckles**.
Absence of fusion plated buckles—Explanation, 22.
Illustrations, 23.
- Buckley, Mr. J. J.**, Dublin, VII.
- Bunbury, Thomas**—No marks used in 1774, 442.
- Burbury, J.**—Mark for silver goods (1830), 485.
- Burdekin, F. T.**—Account of process of manufacture of the heavier plated goods 60 or 70 years ago, 133-6.
- Burdett, John**—No marks used in 1781, 443.
- Burnishing**.
Antiquity of practice, 132.
Plating wire, use in, 81.
Process, 130, 132 (ill.), 130.
Silver edges, use of burnishing in closing up seams (ill.), 84.
Tools (ill.), 81, 84, 131.
Women, employment of, 130, 134.
- Burns Society of Sheffield**—Presentation to widow of the Poet, 155.
- Butt & Co.**, Chester, VIII.
- Butt, John**—Candlestick patent, 247.
- Butter Boats**, *see* title Sauce or Butter Boats.
- Butter Dishes** (ill.), 92, 213.
- Button-making** from fused plated metal, 184.
Boulsover's, T., industry, 14, 16, 17, 27.
Importance in early 18th century, 16.
Locality of manufacture.
Present time, 147.
Removal to Birmingham, 198.
Persistence, 17.
Specimens of buttons (ill.), 18.
- Butts, T.**—Mark (1807), 446.
- Byron, Lord**—Mahogany case containing silver-mounted meerschaum pipe and Old Sheffield Plate tobacco box (ill.), 376.

C

- Caddy Spoons** (ill.), 336.
Fire gilt spoon (ill.), 72.
Tea Shells, 149.
- Cadman, D.**—Mark for silver goods (1780), 474.
- Cadman, George**, 43, 60.
refer also to title Roberts & Cadman, or Roberts, Cadman & Co.
- Cake, Fruit and Bread Baskets**, 205 (ill.), 80, 205-12.
Illustrated designs from catalogues (1770 and 1775), 400, 401.
Rosenstrauch, Cake basket bearing name of, 161.
Sale room values, 183, 184.
- Cambray, F.**, Oxford, VIII.
- Canada, trade with**—One purchaser only traced, 157.
- Candelabra.**
Exhibition of 1851, T. J. & N. Creswick's exhibits, 141.
Illustrations of various designs, 232-44, 296.
Interchangeable candelabra (ill.), 239, 242.
Interchangeable candelabra and épergnes, 231 (ill.), 240, 241, 243.
Origin of form, 231.
Period of manufacture, 231.
Quantity produced, 183.
Sale room values, 184.
Silver Candelabra purchased as Old Sheffield (ill.), 202.
Telescopic Candelabra—Eckhardt's patent, 216 (ill.), 238.
- Candle Snuffers**, *see* Snuffers.
- Candlesticks.**
Antiquity, 214.
Bracket candlesticks, 198.
Britannia metal telescopic candlesticks (ill.), 499.
Chamber candlesticks, 248-9.
Combination chamber candlestick and pair of ordinary table candlesticks, 219 (ill.), 218.
Commonest quality, made in Birmingham, period 1820-30 (ill.), 180.
Designs, 184-5.
Adam candlestick originally purchased in America, 156 and ill.
Architectural terms, inaccurate use of, 219.
Columns, 40.
Flaxman's and Adam's influence, 184—
Illustrated designs from catalogue (about 1780), 406.
Illustrated designs from catalogues (about 1775), 402; (1786), 409; (1788), 410; (1801), 414; (1844), 422.
Ionic column, 214.
Late transitional—Illustrated designs from catalogue (about 1844), 422.
Number and variety of patterns, 215 (ill.), 220-31.
Dies.
Adam period dies, 103.
Illustration, 102—Stampings from dies, 104.
Early examples (ill.), 33.
Export from Sheffield, 1795-1831, extent of, 156.
Filling, 215.
Foreign markets, candlesticks for—Composition for filling, 215.
Hancock's, Joseph, 30 (ill.), 33.
Illustrations of various designs, 33, 199, 218, 220-31.
Manufacturer, difficulties in tracing, 216, 219.
Methods of manufacture, 214.
- Candlesticks**—*Continued.*
Mounts and borders, 215.
Nozzles—S. Roberts's, junr., patent, 43.
Number produced, 183—Explanation, 214.
Parts, 106 *note*.
Patents in connection with snuffers and candlesticks, list of, 245, 247.
Period of production, 185.
"Pricket type" candlestick in the Abbey Church of St. Peter, Gloucester, 214.
Sale room values, 184.
Sconces (ill.), 236, 390.
Silver candlesticks.
Early period, marks borne by candlesticks of, 189.
London made, 191 (ill.), 191.
London market, candlesticks for—Over marking by London Silversmiths, 189-90 (ill.), 190.
Silver Corinthian candlestick by T. Law, 454 (ill.), 454.
Stamped filled candlesticks, 215.
Small candlesticks and nozzles—Illustrated designs from catalogue (1778-88), 405.
Taper candlesticks and winders (ill.), 250, 251.
Telescopic pattern or slide candlesticks, number of, 215.
Different methods of working slides, 216 (ill.), 217.
Roberts's, S., junr., patent, 43.
Walpole's, Horace, purchase, 2.
Winter's, J., business, 40.
- Cannel** (or Kennel) Coal.
Definition and uses, 28 *note*.
Hancock, Joseph, articles made by, 28.
- Card Tray** (ill.), 213.
- Carr, Richard**—Extract from diary, 461.
- Carrington, late Mr. Wm. A.**, of Bakewell, VII.
- Carrington, Major**, of Bideford, VII.
- Cartan & Hawthorn**—Dublin dealer supplied by Watson & Bradbury (1808-14), 153.
- Carter, Richard, Danl. Smith and Robert Sharp**—London silversmiths overmarking Sheffield made silver candlesticks, 190 and ill.
- Carter, W.**—Mark for silver goods (1839), 487.
- Cartwright**—Specification for spring snuffers, 245.
- Casley, Mr. Clement H.**, of Ipswich, VI.
- Casley, Mr. H. C.**—Pipe lighters from Sheffield, use in Holland, 374.
- Castling Furnace**, 66 and ill.
- Castle hotel, Bath.**
Old Sheffield Plate, 56.
Silver plate, 55, 56.
- Castle hotel, Dartmouth**—Old Sheffield Plate in use, 56.
- Castle hotel, Lynton**—Old Sheffield Plate in use, 56.
- Castle hotel, Taunton**—Old Sheffield Plate in use, 56.
- Castleton, Milner & Co.**—Mark for silver goods (1821), 484.
- Catalogues**, Illustrated Catalogues, 396.
Cost of old Catalogue, 397.
Reproductions from, 398-424.
- Catcliffe Glass Works**, 69.
- Causer, J. F.**—Mark (1824), 450.
- Cawton, J.**—Mark for silver goods (1782), 475.
- "Centre," 116.

- Centre-pieces**, *see* Epergues.
- Chamber Candlesticks**, 248-9.
Combination chamber candlestick and pair of ordinary table candlesticks, 219 (ill.), 218.
- Champion, T. & Son**—Mark for silver goods (1826), 485.
- Chantrey, Sir F.**
Designs.
Candelabra and épergues, innovations in designs, 231.
Candlestick (ill.), 229.
Interchangeable candelabra and épergues, 186 (ill.), 240, 241.
Portrait from silver medallion, 193.
- Chapple and Mantell, London**, VIII.
- Charity founded by Mary Parsons** for members of Sheffield silver and plate trade, 2.
- Charkoff, Russian maker**—Mark, 162, 172.
- Chasing.**
Description of process, 73-4 (ill.), 74.
Flat chasing, 72.
Hand-chasing—Wine glass cooler (ill.), 189.
Irish style (ill.), 150, 151, 278.
Repoussé work, or chasing in high relief, 72, 74.
- Chaucer's "Reves Tale,"** reference to Sheffield, 2.
- Cheaper** and less durable goods than Old Sheffield Plate, demand for, V.
- Cheese Toasters**, 251 (ill.), 252.
Illustrated designs from catalogue (about 1822), 418.
- Chesterman, Jas., & Co.**—Mark for silver goods (1862), 491.
- Cheston, T.**—Mark (1809), 447.
- Child, T.**—Mark (1821), 450.
- China**—Country of origin of German silver, 137.
- China Wares**—Increase in range and cheapness, effect on demand for plated articles, 269.
- Chippendale.**
Book of designs, 191-2.
Influence on design, 191-2 and 191 *note*.
Lamerie, Paul, possible inspiration by, 187.
- Chocolate Pots**, 260.
- Christ, Chas. Fred**, Hamburg.—Customer of Watson & Bradbury (1798), 159.
- Christoffe, Mons.**, Paris, VIII.
Adoption of electro-plating process, 142.
- "**Chuck**," 108, 116.
- Churches.**
Articles for, 274 (ill.), 275.
see also Communion Plate, and for particular Churches, *see* their names.
- Cigar Boxes**, 374.
- Cigar Holder** (ill.), 375.
- Clapham, Mr. G. H.**, Manchester, VII.
- Clark, James**, of Kingston, Jamaica—Customer of Watson & Bradbury (1795-7), 158.
- Clark, M., J. Hall and C. Clark**—Mark for silver goods (1808), 481.
- Clark, Wm.**—Dublin dealer supplied by Watson & Bradbury (1802-12), 153.
- Clarke & West**—Irish agents of Roberts, Cadman & Co., 150.
- Clarke, Capt. James**—Old Sheffield inkstand presented to Lord Nelson, 297.
- Clarke, John**—Dublin dealer supplied by Watson & Bradbury (1795-1803), 153.
- Class of persons who purchased Old Sheffield Plate**, 57.
- Claw and Ball Foot**, Origin of, 192.
- Clayton, T.**—Mark for silver goods (1820), 483.
- Cleanliness**, importance in manufacture of Old Sheffield Plate, 53, 133.
- Clements, Henry**, Dublin—Advertisement (1762), 149.
- Clive, Thomas**—Candlestick patents, 247.
- Clinton Arms, Newark**—Silver plate, 55.
- Clock made in Paris** (ill.), 167.
- Close plating.**
Antiquity, V., 5.
Articles suited for, 5, 7.
Buckles, process used for, 22.
Description of process, 6.
Fused plating, process supplanted by, 6.
Heat and moisture, effect of, 7.
Illustrations of close plated articles, 8.
Snuffers, 244, 246.
Tea urn tap, 144.
Ireland, workmen imported for close plating, 150.
Locality of manufacture, 145.
Marks, means of identifying, 444.
Revival.
Early attempts—Patents taken out by Richard Ellis (1779) and Samuel Roberts (1789), 6.
General re-introduction (1807), 428.
Thomason's, Sir E., manufactures (1810 and after), 7.
Steel and iron, only satisfactory method of plating on, 5.
- Coach Lamp**, 394 and ill.
- Coar, H.**—Mark for silver goods (1803), 481.
- Coasters or Decanter Stands.**
Foreign made (ill.), 165.
Illustrated designs from catalogue (1770-90), 399.
Pierced, 200 (ill.), 200.
Period of production, patterns, etc., 253-4 (ill.), 253, 255-7.
Sale room values, 184.
- Cock Device**, 431.
- Cockburn, J.**, Richmond, VIII.
- Cocking, Septimus**—Candlestick, etc., Patents, 247.
- Coffee Biggins, Jugs and Pots** (ill.), 435.
Bodies, method of raising in early period, 62.
Classes, 259-60 (ill.), 260-3.
Combination interchangeable Coffee pot, stand and lamp and teapot (ill.), 259.
Derivation of "biggin," 259.
Dies—Prices, 62.
Early specimen (ill.), 85.
Illustrated design from catalogue (about 1798), 413.
Sale room values, 183.
Silver and Old Sheffield Plate, biggins in (ill.), 201.
- Coffee Services** (ill.), 357, 358.
Combined Coffee service with caddy—Illustrated design from catalogue (about 1795), 412.
German silver electro-plated—Illustrated designs from catalogue (about 1850), 424.
Sale room values, 183.
Style in demand (1850-87), 186.
- Coins**—Silver dollar and forged fused plated dollar, 395 (ill.), 395.

- Coldwell, W.**—Marks.
Plated goods (1806), 446.
Silver goods (1806), 481.
- Cole & Son**, Sherborne VIII.
- Collectors.**
Advice to, 173-95.
Renovation, 178-81.
Reproductions or "Fakes," 174-8.
Edges—Method of treatment preferred, 84.
Glass, value set on old crystals, 70.
Ignorance of average collector as to process of manufacture, 1.
Pewter ware, increased interest in, 501.
- Colley, T.**—Mark for silver goods (1783), 475.
- Colmore, S.**—Mark (1790), 445.
- Colonies**, Trade with—Cause of cessation, etc., 58.
- Colour.**
Old Sheffield Plate, comparison with electroplate, 173.
Pure and standard silver, difference in colour, 94.
- Colthirst, James**, of Kingstown, Jamaica—Customer of Watson & Bradbury (1796-8), 158.
- Comber, J.**, Woking, VIII.
- Combined and Interchangeable Articles.**
Candelabra (ill.), 239, 242.
Candelabra and épergnes, 231 (ill.), 240, 241, 243.
Chamber candlestick and ordinary table candlesticks, 219 (ill.), 218.
Coffee service with caddy—Illustrated design from catalogue, 412.
Cruet and pickle frame (ill.), 274.
Cruet or soy frame combination, 273.
Egg frames and toast racks, egg boilers and salts, etc. (ill.), 370-3.
Inkstand, sand sprinkler and candlestick (ill.), 394.
Pot à sucre avec 12 cuilliers autour (ill.), 57.
Sheraton, possible influence of, 368.
- Comfores**, 198.
- Communion Plate**, 274 (ill.), 275.
Flagon at St. Paul's Church, Sheffield, 37, *note*.
French made, 275 (ill.), 168.
Sheffield Infirmary, 2.
- Connor, Thos.**—Dublin dealer supplied by Watson & Bradbury (1806-13), 153.
- Constantine, Richard**—White metal manufacturer, 494.
- Continental Countries.**
Importation from, of wares made from fused copper plate, 160.
Period of, 160.
for particular countries, *see* their names.
Reproductions or "fakes," manufacture of, 174.
Classes of articles, 175.
☐ Detection, means of, 176.
Trade with, in Old Sheffield Plate, 158-9.
Cessation, cause of, 58.
Opportunity lost in 1810, 45.
for particular countries, *see* their names.
- Cooper B. & P.**, New York—Customers of Watson & Bradbury (1815-7), 157, 158.
- Cooper, Fellows & Co.**, 158.
- Cooper, G.**—Mark for silver goods (1788), 477; (1800), 480.
- Cooper, J.**—Mark for silver goods (1784), 476.
- Cooper, Jerh.**, New York—Customer of Watson & Bradbury (1821), 157, 158.
- Cooper, T.**—Mark for silver goods (1802), 481.
- Coopland, H.**, Sheffield, VIII.
- Cope, C. G.**—Mark (1817), 449.
- Copper Ingot** prepared for plating by fusion (ill.), 12—
After plating (ill.), 13.
- Coppers**, 105.
- Cork.**—Silver handled & plated Cutlery industry wrongly associated with Cork, 455.
- Cormick, Mrs. Ann**—Dublin dealer supplied by Watson & Bradbury (1795-8), 153.
- Corn, J., & J. Sheppard**—Mark (1819), 449.
- Cosins, I.**—Mark for silver goods (1774), 473.
- Cottam, Mr. G. H.**, VII.
- Covers**, *see* Dish and Plate Covers.
- Cowlishaw, J. Y.**—Mark for silver goods (1854), 489.
- Cracknall, J.**—Mark (1814), 448.
"Cramped Seam," 111, and ill.
- Crawshaw, A.**—Mark for silver goods (1826), 485.
- Crawshaw, J.**—Mark for silver goods (1816), 483.
- Cream Bason**—Illustrated design from catalogue (about 1798), 413.
- Cream Jugs.**
Britannia Metal (ill.), 498.
Helmet cream—Illustrated design from catalogue (about 1784), 408.
Uses in earliest period of production, period when first manufactured as part of services, 341 (ill.), 339, 343-4.
- Crests, Monograms, Inscriptions, etc.**
Engraving.
Method in use before invention of soldering or rubbing in silver shields, 87, 89 (ill.), 88.
Proportion of silver required, 87, 89.
Shields for, *see* title Shields.
Number of Crests and Coats of Arms found on Old Sheffield Plate, 88.
- Creswick & Co.**—Mark for silver goods (1858), 490; (1863), 491.
- Creswick Family**, 437.
- Creswick, Joseph**—Mark for silver goods (1777), 474; (1793), 478.
- Creswick, Richard**, 38 *note*, 437, 463 *note*.
Registration at Goldsmiths' Hall, 463.
- Creswick, T. & J.**
Articles manufactured by, illustrations, etc., 1, 201, 209, 239, 242, 256, 262, 270, 286, 296, 314, 319, 332, 392.
Confusion with Fenton, Creswick & Co., otherwise T. Watson & Co., 37.
Marks.
Plated goods.
Registered mark (1811), 37, 437, 448.
Unregistered marks (1811), 448.
Silver goods (1810), 482.
- Creswick, T. J. & N.**
Articles manufactured by (ill.), 209, 260, 264, 296, 300, 325.
Exhibition of 1851, exhibits at, 141, 437.
Mark for silver goods (1819), 483; (1832), 486; (1852), 488; (1853), 488.
- Crichton Bros.**, 353, 466.
- Crichton, Mr. L.**, of London, VII.

- Cross Arrows Device**, 437.
Cross Keys Hotel, Hull.—Silver plate, 55.
Crossed Keys Device, 434.
Crown Device, 434-5.
Crown stamped upside down on Sheffield assayed silver (1815-9)—Purpose, 464-5.
Cruet Frames and Soy Frames, 271.
 Demand and price, decline in, 304.
 Derivation of "soy," 271.
 Illustrated designs from catalogues (about 1778), 404.
 Illustrations of various designs, 55, 70, 271-4.
 Number of patterns, 271.
 Sale room values, 184.
Cups, 151 (ill.), 150, 348-9, 351.
Curtis & Horspool, Leicester, VIII.
Custard or Junket Dish (ill.), 92.
Cutlers' Company of Sheffield (Corporation of Cutlers).
 Apprentices employed in silver and plate trade and not instructed in cutlery, complaints as to, 31.
 Box-making enterprise, 19.
 Button-making trade, defence of, 16.
 Bye-laws, first code (1625), 4.
 Middle-man, goods received as, 17.
Cutlery—Green stained ivory handled knives and forks, 457 and ill.
Cutlery—Old Sheffield and silver-handled cutlery, 453 (ill.), 455, 456.
 Antiquity of practice of plating knives, 4.
 Date of introduction, 453.
 Durability and cost, comparison between silver and Sheffield Plate handles, 453.
 Locality of industry, restriction to Sheffield, 455.
 London cutlers, silver handles made by, 455.
 Makers and their marks, 455.
 Lists of names and marks, 458, 459.
 Silver handles, marks on—Absence of hall marks, etc., 453-4.
 Method of manufacture, 453.
Cutlery Industry.
 Parent industry of Silver Plate manufactures of Sheffield, V.
 Works, stock-in-trade required (1775), 66.
Cutts, J. P.—Mark for silver goods (1842), 487.

D

- Dalton, G.**—Mark for silver goods (1794), 479.
Daly, John—Dublin dealer supplied by Watson & Bradbury (1796-1810), 153.
Damant, W.—Mark for silver goods (1775), 473.
Daniell, Thomas, London silversmith—Mark, 471.
Darby, W.—Mark for silver goods (1785), 476.
Date Letters on Sheffield-made silver, 464-466.
 List in chronological order, 467-9.
 Sources whence list was compiled, 466.
Dates of Specimens of Old Sheffield Plate.
 Groups of articles, dates assigned to, 184-6.
 Methods of ascertaining, means afforded by silver articles of same or similar design, 200, 277.
Davidson, L.—Mark for silver goods (1787), 477.
Davis & Brown, Boston—Customers of Watson & Bradbury (1816-7), 157.
Davis, J.—Mark (1816), 449.
Davis, D. & M., Birmingham, VIII.
Davis, D. F., Manchester, VIII.
Dawson, H., Wilkinson & Co.—Mark for silver goods (1833), 486.
De Landre, Bartw.—Dublin dealer supplied by Watson & Bradbury (1795-1805), 153.
Deakin, G., & Co.—Mark for silver goods (1849), 488.
Deakin, S., A. Kitchen & Co.—Mark for silver goods (1781), 475.
Deakin, Smith & Co.—Mark (1785), 445.
Dealing in Old Silver and Old Sheffield Plate, methods of, 181-2.
Decanter (ill.), 253.
Decanter Labels (ill.), 303.
Decanter Stands, *see* Coasters.
Decline and Disappearance of Fused Plated Industry, 58-60, 133.
 Callings adopted by partners in old firms, 59.
 Date after which records ceased, 133.
 Date when process of plating by fusion was practically abandoned, 138, 141.
 Extent—Old process never entirely disused, 137.
 Last notification of manufacturers working in fused plated wares, 142.
 Transitional period, 133.
Decorations—Thomas Nicholson's innovations, 45.
Definition of term Old Sheffield Plate, 1.
Degournay's Manufactory, 167-8.
Dellevie Bros., Hamburg—Customers of Watson & Bradbury (1797-1806), 159.
Demand for Old Sheffield Plate.
 Classes of purchasers.
 Inn proprietors, 54.
 Middle class, demand among new middle class early in 19th century, 57.
 Nobility and gentry, 56.
 Duty on silver imposed in 1784, effect of, 56.
 Growth, 56.
 Ireland, *see* that title.
Derbyshire Glass Industry (Whittington), 67, 68-9.
Designs.
 Decadence revealed by illustrated catalogues, 396-7.
 Early makers, quality of designs, 51.
 Imitation of one manufacturer by another, 203.
 Ingenuity displayed in ringing changes on patterns, 397 (ill.), 402.
 Period of production impossible to determine by design, 186.
 Trade between different makers, 219.
 Variety of, 186.
 for particular articles or periods, *see* their names.
Dessert Stands, *see* title Epergnes, Centre-pieces, &c.
Dever—Mark, 452.
Devight, Jasett, Montreal.—Customer of Watson & Bradbury (1816), 157.
Dewsnap, John—Marks.
 Cutlery—None found, (1787), 459.
 Silver goods (1781), 475; (1803), 481.
Dewsnap or Dewsnop, Joshua—Marks for cutlery goods (1774), 458; (1787), 459.

- Dewsnap, P.**—Mark for silver goods (1819), 483.
- Dewsnap, W.**—Mark for silver goods (1786), 476.
- Dickenson, George**—Assay Master (1789), 464.
- Dickenson, J.**—Mark for silver goods (1780), 474.
- Dickenson, W.,** Bath, VIII.
- Didot, Leger**—Candlestick patents, 247.
- Dies and Die-Work.**
 Bodies of articles such as coffee pots, etc., dies not used for, 62.
 Candlesticks, dies for (ill.), 102—Stampings from dies (ill.), 103.
 Cast metal dies, 101.
 Cutting dies—Makers depending on local ingenuity and taste, 60.
 Dispersal and destruction—Dies melted down for value of metal, etc., 58-9.
 "Adam" and subsequent plainer patterns of dies, 59.
 Boulton's, Matthew, 60.
 Class of patterns particularly condemned, 59.
 Gainsford & Nicholson's, 60.
 Period, 58.
 Sissons, W. & G., exception in case of—Explanation, 59-60 and 60 *note*.
 Earliest specimens.
 Clear and sharp definition of detail lacking, 99.
 Small number of articles of exactly the same design—Probable use of cast metal dies, 101.
 Entrée dishes, dies for stamping (ill.), 100—Stampings from dies (ill.), 101.
 Fixing dies, 105.
 History of, 99.
 Introduction, 57.
 Joints or hinges, use for, 61, 62.
 List of dies in use in 1775, with descriptions from books of an old manufactory, 61-2.
 Prices, early trade prices from books of an old manufactory, 61.
 Stamping, 105.
- Dinner Plates,** *see* Plates.
- Dish and Plate Covers.**
 France, specimens made in (ill.), 164, 165, 166.
 Illustrations of various designs, 264-8.
 Proportions, uses, etc., 264.
 Sale room values, 183.
- Dish Crosses** (ill.), 62, 267, 283.
 Dies—Prices, 62.
- Dish Rings and Rims,** 276 (ill.), 278-83.
 Classes, 276 (ill.), 278-83.
 Irish Rings, 276, (ill.) 278, 279.
 Process of manufacture, 277.
 Purpose, 276, 277.
 Sale room values of pierced rings, 184.
- Dish Wedge** (ill.), 392.
- Dishes or Trenchers.**
 Decline in demand for large plated dishes, 268.
 Meat dishes, 268.
 Parish Church of Sheffield, specimen at, 1.
 Venison Dish (ill.), 266.
see also title Entrée, Breakfast, Hash, etc., Dishes.
- Dixon & Smith**—Britannia Metalsmiths, 496.
 Articles made by (ill.), 498, 499.
 Mark (1804), 497.
- Dixon, Charles,** Candlestick maker (1776-1852), recollections of first makers, 13-4.
 Boulsover, T., 13-4.
 Britannia Metal, references to origin of, 495.
 Hancock, Joseph, 27, 30-1, 335.
- Dixon, Gilbert,** 69, *note*.
- Dixon, J., & Son.**
 Articles made by (ill.), 244, 332, 462, 499.
 Britannia Metal business, 496.
 Marks.
 Britannia Metal goods (1830), 497.
 Silver goods (1829), 485.
- Dixon, James, & Sons,** 45.
 Britannia Metal business, exhibits at exhibition of 1851, etc., 496.
 Illustrated designs from Catalogue (about 1848), 423.
 Marks.
 Britannia Metal goods (1833), 496, 497.
 Plated goods (1835), 347, 451.
 Silver goods (1867), 492.
 United States, trade with, 58, *note*.
- Dixon, Jno.,** "Glass House," also described as Jno. Dixon "at Whittington."—Glass supplied to M. Fenton & Co. and Watson & Bradbury, 67, 69.
- Dixon, Mr. James,** of Sheffield, VII., 58, *note*.
- Dixon, Mr. Lennox,** of Sheffield, VII.
 Ingredients of Britannia Metal, 496.
- Dixon, Mark,** 81.
- Dixon, Richard,** Glass maker, 69.
- Dixon, T., & Co.**—Mark (1784), 444.
- Dobson & Son,** London, VIII.
- Dodd, G.**—Mark for silver goods (1819), 483.
- Dodge, W. & M.**—Mark for silver goods (1866), 492.
 "Dogs," 105.
- D'Olier, Jerh.**—Dublin dealer supplied by Watson & Bradbury (1795-1800), 153.
- D'Olier Family,** 397.
- Dollars**—Silver and forged fused plated dollars, 395 and ill.
 "Double Dishes," 283.
- Double-side Plating.**
 Date of discovery, 30, 75.
 Salt cellar by Tudor & Leader, evidence of marks on, 309.
 Silver, proportion of, used, 78.
- Dove and Olive Branch Device,** 437.
- Drabble, J. (I.), & Co.**—Marks.
 Plated goods (1805), 433, 446.
 Silver goods (1805), 481.
- Drabble, James,** 433.
- Drabble, Joseph,** 59.
- Drafting Punch** (ill.), 103.
- Draw Bench** (1775), 106-7 (ill.), 106.
- Draw Handle,** Adam period (ill.), 388.
- Drawing Wire Process,** 107 and ill.
- Dublin**—Market in which to obtain Old Sheffield Plate, 147-8.
- Duff, John**—Patent Snuffers, 245.
- Duhn, Johann Hermann Von,** Lübeck—Customer of Watson & Bradbury (1804), 159.
- Duke, H.**—Mark for silver goods (1837), 487.
- Dunn, George Bott**—Mark, (1810) 436, 447.
- Dunthorne, E. E.,** Liverpool, VIII.
- Durability of Old Sheffield Plate,** 180 and ill.

- Durand of Paris**, 170.
Dish cover by (ill.), 166.
Mark, 172.
- Duty on Silver.**
Duty imposed in 1784, 465.
Demand for Sheffield Plate, effect on, 56.
Duty marks, 464, 465, 466—List, 467-469.
Ireland, 150, 466.
Increases in 1797, 1804 and 1815, 466.
Ireland—Duty imposed in 1730, 150, 466.
- Dyson, A.**—Mark for silver goods (1835), 486.
- E**
- Eadon, G., & Co., or Eadon, Kibble & Weaver,**
Articles made by (ill.), 262, 315, 317, 370, 392.
Mark for silver goods (1795), 479.
- Ear Speculum**, series of (ill.), 390.
- Ear Trumpet**, folding pocket (ill.), 390.
- Early Manufacturers of Old Sheffield Plate**, 25-51.
Longevity, 51.
Number of firms still remaining as plate-workers, 58.
Quality of designs and workmanship, 51.
Scantiness of records, 51.
for particular makers, *see* their names.
- Eaton, T. W.**—Mark for silver goods (1844), 487.
- Eckhardt, A. J., & Morton**—Patent for telescopic candlesticks and candelabra (Eckhardt's Patent), 185, 216.
Telescopic candelabra (ill.), 238.
- Edges, Silver Edges**—Introduction of silver-threaded edges by Roberts & Cadman, 82, 185, 253-4.
French ware, silver-threaded edges rarely found, 160.
Hard soldered edges, 92 and ill.
Illustrations, 83, 85, 86.
First illustrations in catalogues of articles described as having silver edges—Reproduction, 411.
Process of making edges, 82.
Roberts's, Samuel, patent for dispensing with silver edges, 84.
- Edinburgh Manufacture of Sheffield Plate**—Evidence against supposition, 155.
- Edward III.**—Visit to Sheffield, 2.
- Edwards, George**—Mark for silver goods (1861), 490.
- Eel Pie Dish** in use at Red Lion Hotel, Salisbury, 56, *note*.
- Egg Boilers** (ill.), 372, 373.
- Egg Frames and combined articles**, 368 (ill.), 370, 371-2.
- Elam, John**, 41, 42.
- Electro-plating.**
Colour, comparison with colour of Old Sheffield Plate, 173.
Cost of workmanship, comparison with fused plating, 139.
Effect of replating on Old Sheffield Plate, 173.
Engraving, 96.
France, introduction in, 142, 165.
Fusion plating supplanted by, 1.
Date when plating by fusion was practically abandoned, 138, 141.
France, 142, 165.
Future of, expert opinion—Notice of Messrs. Elkington's exhibits in 1851, 141.
Origin of invention, 139-40.
- Electro-plating**—*Continued.*
Process, 142-3.
Proportion of silver required, comparison with fused plating, 139.
Saving of labour, 143-4.
Softness of wares as compared with Old Sheffield Plate, 173.
Spoons and forks, manufacture of—Effect of discovery, 338.
Workmanship, effect on, 53.
- Elephant's Head Device**, 47, 274, 437.
- Elkington & Co., Birmingham.**
Electro-plating patents, 140.
Conditions offered to those wishing to study electro-plating, 141.
Date of expiry, 142.
Exhibition of 1851, exhibits at, 141.
- Elkington & Co., London**, VIII.
- Elkington & Radcliffe**—Bright plating secret, 140.
- Elkington, Mason & Co.**—Mark for silver goods (1859), 490.
- Ellerby, W.**—Mark (1803), 445.
- Ellin, Mr. T. R.,** of Sheffield, VII.
- Elliott, Joseph**, 437 *note*.
- Elliott, Thomas**—No marks used (1774), 442.
- Ellis, Charles, & Sons**, 13.
- Ellis, Isaac**, 60.
- Ellis, J., & Co.**—Mark for silver goods (1793), 478.
- Ellis, J., P. Spurr and P. Cadman, Junr.**—Mark for silver goods (1801), 481.
- Ellis, Mr. J. Devonshire**—Armour plating patent, origin of, 13 *note*.
- Ellis, Mr. P. M.,** of Birmingham, VII.
- Ellis, Mr. W. Adcock**, of firm Charles Ellis & Sons—Information furnished, etc., VII., 11 *note*, 146, 147.
Description of process of fusion plating, 11-12.
- Ellis, Richard**—Improved patent for close plating (1779), 6.
- Ellis, Samuel**—Cutting of dies, 60.
Charges, 61.
- Ellis, T.**—Mark for silver goods (1867), 492.
- Ellis, Thomas**—No mark used (1774), 442.
- Emanuel, E.,** Portsea, VIII.
- Emanuel, M.,** Southampton, VIII.
- Emden, Bernhord Lion**, Hamburg—Customer of Watson & Bradbury (1801-6), 159.
- Engraving.**
Bands for, soldering on, 89 (ill.), 91.
Bright cut deep engraving, 86 and ill.
Crests, Monograms and Inscriptions, proportion of silver needed, etc., 87, 89 (ill.), 88.
see also title Shields.
Distinguishing from flat chasing, means of, 87.
Electro-plating system, 96.
Introduction, 185.
Process, 87.
Shields for engraving, *see* title Shields.
- Entrée, Vegetable, Breakfast, etc., Dishes**, 283.
Descriptions in 18th century books, 283.
Dies for (ill.), 100—Stampings from dies (ill.), 101.
Illustrated designs from catalogue (about 1818), 417.
Illustrations of various designs, 283-9.
Sale room values, 183.
"Warmers," 283-4 (ill.), 286, 287, 288, 289.

Epergnes, Centre-pieces, Dessert Stands and Plateaux, 290.
 Designs (1850-87), 186.
 Early centre-pieces, 290 (ill.), 291.
 Glasses, value set on original glasses, 70.
 Illustrated design from catalogue (about 1839), 420.
 Interchangeable candelabra and épergne, 231 (ill.), 240, 241, 243.
 Late 18th and early 19th century épergnes, 290 (ill.), 292, 293.
 Late Georgian épergnes, workmanship, etc., 290 (ill.), 294-6.
 Sale room values, 183.

Etches, J. M.—Mark for silver goods (1820), 484.

Eustance & Co., Warrington, VIII.

Evans, S.—Mark (1816), 449.

Exhibition of 1851.

Britannia Metal—Exhibits of James Dixon & Sons, 496.

Electro-plating—Notice of Messrs. Elkington's exhibits, 141.

Old Sheffield Plate exhibits, etc., 141, 437.

Extent of trade in Old Sheffield Plate during period of its production, comparison with trade in solid silver articles, 396.

Eyre, J., & Co.—Mark for silver goods (1818), 483.

Eyre, John, 41, 42.

F

Factories, Old Sheffield Plate Factories.

Absence of, in early days of manufacture, 164.

Boulton's Soho Factory (ill.), 49.

First factory, establishment by Tudor & Leader, 34.

Furnaces, 66 and ill.

Nicholson's factory (ill.), 46.

Not especially built as a rule, 65.

Size, 66.

Limitations of space, reason for non-adaptation to electro-plating process, 59.

Stripping place, 67 and ill.

Workshops, list of, with contents and values (1775), 63-5.

Fairbairn, Partner in Firm of A. Goodman & Co., 437.

"**Fakes**," see title Reproductions or "Fakes."

Faraday, Professor, 140.

Farnham & Ward, Boston—Customers of Watson & Bradbury (1816), 157.

"**Father**" of Fused Plated Industry, 28-9.

Fearn, J. & G.—Mark for silver goods (1823), 484.

Fearon, Collins & Co.—Glass supplied to M. Fenton & Co. and Watson & Bradbury, 68.

Fellows & Read, New York—Customers of Watson & Bradbury (1824), 157, 158.

Fellows & Younge, New York—Customers of Watson & Bradbury (1816-9), 157.

Fellows, James, New York—Customer of Watson & Bradbury (1820-4), 157.

Fenton, Allanson & Co.—Mark for silver goods (1816), 483.

Fenton & Anderton—Mark for silver goods (1857), 489.

Fenton Bros.—Mark for silver goods (1860), 490; (1868), 492.

Fenton, Danby & Webster—Mark for silver goods (1824), 484.

Fenton, J. F.—Mark for silver goods (1856), 489.

Fenton, James, 37 *note*.

Fenton, James, of Birmingham—Mark for silver goods (1854), 489.

Fenton, John, 37.

Fenton, John, & Co.—Mark for silver goods (1799), 480.

Fenton, M., & Co. or Fenton, Creswick & Co., Fenton, Creswick, Oakes & Co. (T. Bradbury & Sons' predecessors), 15, 16, 31, 37, 38.

Articles made by, illustrations, etc., 156, 200, 209, 210, 219, 221, 222, 223, 225, 226, 230, 260, 308, 311, 314, 316, 317, 338 *note*, 342, 343, 349, 377.

Cake basket, initials on base of, 210.

Silver candlesticks, punch found on, 189.

Boulsover, transactions with, 16.

Glass—List of manufacturers supplying glass to M. Fenton & Co., 67-8.

Hancock's, Joseph, work for, 15.

Marks

Plated goods (before 1773) 441; (1774),

none used, 442; (1781), 443.

Silver goods (1773), 472.

Members of first Association of Sheffield silversmiths, 51.

Watson, T., & Co., firm known as—Confusion with T. & J. Creswick, 37.

Fenton, Matthew, 36, 37, 38 *note*, 437.

Registration at Goldsmiths' Hall, London, 38, 463.

Fenton, Matthew, Junr., 38.

Fenton, William—Charges for dies, 61.

Ferguson, Geo., Amsterdam—Customer of Watson & Bradbury (1802), 159.

Fieldhouse, Mr. W. J., Wooten Wawen, VIII.

Fire-gilding.

Description of process, 71.

Specimens of work (ill.), 72, 189.

Firmin & Sons, Button-makers, of London, 17.

Fish Slices.

Chased (ill.), 392.

"Fish Knives," 198.

French fish slice (ill.), 163.

Pierced (ill.), 121, 392.

Fitzwilliam, Earl, VII.

Flask with Cover (ill.), 388.

Flat Chasing, 72.

Flat Hammering.

Durability secured, 53.

Importance and difficulty, 53, 126.

Process, 126-9 (ill.), 127.

Flaxman, John.

Influence on design.

Candlestick (ill.), 221.

Illustrated designs from catalogues (1780 & 1782), 406, 407.

Mounted vases, jugs, etc., designs for, 338.

Tea urn with Flaxman medallion (ill.), 363.

Portrait of a silver medallion, 193.

Flaxman-Nelson Vase, 298.

Fletcher & Gardiner, Philadelphia—Customers of Watson & Bradbury (1815), 157.

- Fletcher, Joseph**, cutler (1726), 27.
- Fleur-de-lis, Canterbury**—Silver plate, 55.
- Fleur-de-lis Device**, 435, 436.
- Fluctuations in Old Plate trade**—T. Nicholson's lifetime, 45-6.
- Foot Lathes** (1775), 108 and ill.
- Ford & Son**, Newark, VIII.
- Ford & Son**, Sheffield, VIII.
- Foreign Countries**, *see* title Continental Countries, *also* names of Countries.
- Forks and Spoons.**
Comparative failure of Old Sheffield makers, 335.
Hancock, Joseph, spoons and forks made by, 30.
Process of manufacture, difficulties, etc., 335 (ill.), 336.
Electro-plating discovery, effect of, 338.
Modern method (ill.), 337.
Silver spoons and forks, absorption of production by Sheffield makers, 338.
- Fortescue and Royal Hotel, Barnstaple**, Old Sheffield Plate in use, 56.
- Foster, R.**—Mark for silver goods (1780), 474.
- Fowl Dish** (ill.), 289.
- Fox, Samuel & Ann**—Mark for silver goods (1793), 478.
- Fox, T., & Co.**
Articles made by (ill.), 311, 314, 341, 343, 466.
Marks.
Plated goods (1784), 444.
Silver goods (1784), 476.
- Fox, W.**—Mark for silver goods (1775), 473.
- France.**
French plating, *see* that title.
Plated ware made in (ill.), 163-9.
Electro-plating, introduction of, 142, 165.
History of industry, 164-70.
Gauge of plated metal, price, etc., 160.
Importation, 160.
Period of, 160.
Marks, 170, 171-2.
Proportion of silver, mark used to indicate, 78.
Spinning, method of, 116.
Trade with, in Old Sheffield Plate, effect of French Revolution, etc., 57.
- Franckel & Co.**, Hamburg—Customers of Watson & Bradbury (1796-1804), 159.
- Franklin & Hare**, Taunton, VIII.
- Franklin, Joshua**—Dublin dealer supplied by Watson & Bradbury (1808-11), 153.
- Freake, Sir T., Bart.**, VII.
- Freeman, Mark**—Candlestick, etc., patent, 247.
- Freeman, T.**—Mark for silver goods (1845), 488.
- Freemantle, Mr. W. T.**, Barbot Hall, Rotherham, VII.
- Freeth, H.**—Marks (1816), 449.
- French Plating.**
Close plating, confusion with, misleading use of term "French plater" in old directories, 145 *and note*.
Durability and applicability, extent of, 96, 97.
Invention in France, 165, 167.
Date of invention, 97.
Process, 4, 96.
Repairs, value for, 96 *and note* (ill.), 97.
- Froggatt, Coldwell & Lean**, Britannia Metalsmiths, 494.
Mark (1797), 445.
- Fuller, William**, Dublin—Advertisement (1770), 149.
- Furnaces in early Factories**—Casting and plating furnaces, 66 and ill.
- Furness, Poles & Turner**—Mark for silver goods (1810), 482.
- Fusion Plating.**
Boulsover's discovery, 5, 9, 139.
Copper ingots before and after process (ill.), 12, 13.
Description of process by Mr. W. A. Ellis, 11-12.
Four sides of ingot, plating on, 12.
France, use in, 167.
Gauges of silver, 11 *note*.
- G**
- Gainsford & Nicholson**, 38, 138.
Articles made by, illustrations, etc. 95, 186, 229, 240, 241, 285, 287, 299, 319, 322, 323, 326, 328, 349, 356, 357.
Auction of dies, vices, tools, etc., on dissolution of firm, 60.
Extent of trade (1812-26), 46.
Mark (1808), 47.
- Gainsford, Fenton & Nicholson**, 38.
- Gainsford, Robert**, 38, 138.
Marks.
Plated goods (1808), 274, 437, 447.
Silver goods (1808), 482.
Sacred edifices, articles made for, 274 (ill.), 275.
- Gales & Martin**, Directory for 1787.
List of articles made in Old Sheffield Plate, 196.
Table knife makers, list of, 459.
- Gallimore, W., & Co.**—Mark for silver goods (1867), 492.
- Galton, H. C.**, Christchurch, VIII.
- Gandais**, 170,
Dinner plate by (ill.) 168.
Mark, 172.
- Gardiner, Veron & Co.**, Philadelphia—Customers of Watson & Bradbury (1819-24), 157.
- Garnett, W.**—Mark (1803), 445.
- Garrard, Messrs.**, of London.
Name found on articles of Old Sheffield Plate made about 1830-45, 146 *note*.
Purchase of plated metals from Birmingham firm, 146.
- Gas**, Introduction of, and use for soldering purposes—Advertisement by Green & Pickslay, 122.
- Gatchall, Saml.**—Dublin dealer supplied by Watson & Bradbury (1799-1813), 153.
- Gauge of Plated Metal**, 57, 78-9, 86, 160.
- George Hotel, Aylesbury**—Old Sheffield Plate in use, 56.
- George, J. H.**, Bristol, VIII.
- George IV.** and Wine wagons, 254.
- German Silver**, adoption as basis for plated goods, 133.
Advantages as compared with copper, 139.
"Argentine"—Name applied to German Silver, 137.
Articles made in.
Candlestick (ill.), 231.
Spoons and forks first manufactured from Argentine by W. Hutton & Sons, 338.
Wine cooler (ill.), 386.

German Silver—Continued.

- Casting in, from models, use of dies superseded by, 58.
 Cost as compared with alloyed copper previously used, 138.
 Country of origin—China, 137.
 Date of introduction, 137, 138.
 Ductility, lack of, 139.
 Ingredients, 138.
 Johnstone's, Mr. A. S., notes, 138-9.
 Merry's patent, 138.
 Name, origin of, 137.
 Nicholson's, T., experiments, 47.
 Oxidation, liability to, comparison with copper and its alloys, 139 (ill.), 144.
 Roberts's, S., junr., patent, 43.
- Gibbons, Brueton**, Birmingham—Glass supplied to M. Fenton & Co. and Watson & Bradbury, 68.
- Gibbs, G.**—Marks (1808), 447.
- Gilbert, J.**—Marks.
 Plated goods (1812), 448.
 Silver goods (1841), 487.
- "**Gilbert, London**"
 Mark (1840), 452.
 Small telescope (ill.), 390.
- Gilding**, 71, (ill.), 72, 189.
- Glad, Peter Wm.**, Amsterdam—Customer of Watson & Bradbury (1802), 159.
- Glass** used by Old Sheffield Platers.
 Colour, variety of tints due to impurities in ingredients, 70.
 Cost of production, 70.
 Cruet (ill.), 70.
 Sources of supply, 67-9, 271.
 Value attached to original crystals by collectors, 70.
- Globe and Cross Device**, 436.
- Gloucester, Abbey Church of St. Peter**—Candlestick of "Pricket type," 214.
- Goblet** (ill.), 349.
- Gold**, Application of, 71.
- Goldsmiths' Hall**, London, 501.
 Complaints of deception by plated goods (1327), 4.
 Local assay offices in Sheffield and Birmingham, opposition to establishment of, 426.
 Pewterers, dispute with, 501.
 Sheffield silversmiths registered with, 38, 463.
- Goodman, A., & Co. or Goodman, Gainsford & Fairbairn.**
 Articles made by (ill.), 203, 262, 306, 369, 371.
 Marks.
 Plated goods (1800), 437, 445.
 Silver goods (1801), 481.
- Goodman, A., Gainsford & Co.**—Mark for silver goods (1797), 479.
- Goodman, Alex.**, 438.
- Goodwin, Charles**—Candlestick patents, 247.
- Goodwin, E.**—Marks.
 Plated goods (1794), 445.
 Silver goods (1796), 479.
- Goodwin, Rev. Edward**, 27.
- Gower, Nathaniel**—Early manufacturer of Britannia Metal, 495.
- Gravy Holders**, 203-4 (ill.), 203.
- Gray, Robert**, Glasgow—Purchaser of Old Sheffield Plate from Watson & Bradbury, 154.

- Greaves, Edmund**—Patent for bringing up candle by turning a screw, 245.
- Greaves, Johanadab**—No marks used (1774), 442.
- Greaves, S. & Co.**—Mark for silver goods (1774), 473.
- Greaves, T.**—Mark for silver goods (1789), 477.
- Green & Hatfield**, Ipswich, VIII.
- Green & Pickslay**—Advertisement on introduction of gas, 122.
- Green, Bradbury & Firth**—Mark for silver goods (1828), 485.
- Green, J.**—Mark for silver goods (1778), 474; (1783), 475; (1785), 476.
- Green, J.**—Mark for silver goods (1846), 488.
- Green, J.**, of Birmingham—Mark (1807), 446.
- Green, J., & G. Hague**—Mark for silver goods (1793), 478.
- Green, John**, 42, 434 *note*.
- Green, J., & Co.**, 42.
 Candelabrum made by (ill.), 237.
 Mark (1799), 434, 445.
- Green, John**, cutler (c. 1732), 26.
- Green, Roberts & Mosley** (J. Green, Roberts, Moseley & Co.), 42.
 Mark for silver goods (1793), 478.
- Green stained Ivory** for Knife Handles, etc., 457 and ill.
- Green, William, & Co.**—Marks.
 Cutlery (1787), 459.
 Plated goods (1784), 444.
 Same mark for cutlery and plated goods, 459.
 Silver goods (1784), 476.
- Greenberg, I. S.**, Birmingham, VIII.
- Greenway, Charles**—Patent for improvement in snuffers, 247.
- Greenwood & Sons**, York, VIII.
- Gregory, J., & Co.**—Mark for silver goods (1795), 479.
- Gregory, R., & Co.**—Mark for silver goods (1797), 479.
- Gregory, Wostenholme & Co.**—Mark for silver goods (1809), 482.
- Guardians of Assay Office**, VI., VII.
- Guitike, Mr.**—Introduction of German silver, 137.

H

- Haddock, Mr. W. Thorpe**, of Sheffield, VII.
- Hadfield, A.**
 Mark for silver goods (1818), 483.
 Articles made by (ill.) 8.
- Half Moon Device**, 36.
- Haggie, Mr. Norman**, Sunderland, VII.
- Hague & Beaumont**—Dublin dealers supplied by Watson & Bradbury (1800-3), 153.
- Hague & Nowill**—Mark for silver goods (1786), 476.
- Hague, G.**—Mark for silver goods (1798), 480.
- Hall, Henry**—Mark (1829), 450.
- Hall, John, & Co.**, Manchester, VIII.
- Hall, L.**, Louth, VIII.
- Hall, W.**—Mark (1820), 449.
- Hamburg**, Sheffield Plate in, 159.

- Hamilton, Lady**, Female mask on Warwick Vase copied from, alleged, 381 *note*.
- Hamilton, Mr. H.**, Belfast, VII.
- Hamilton, Sir William.**
Book on Antique Classical Figures, use in design, 188.
Warwick Vase, purchase and restoration of, 391 *and note*.
- Hammering**, Flat Hammering, *see* that title.
- Hammering Stake** (ill.), 128.
- Hammond, C.**—Mark for silver goods (1824), 484.
- Hamy, Wm.**—Dublin dealer supplied by Watson & Bradbury (1808-13), 153.
- Hancock, Ebenezer**, 29.
- Hancock, Ebenezer, and Richard Jessop**, First Britannia metal manufacturers, alleged, 29.
- Hancock, Isaac**, 17, 26.
- Hancock, Joseph.**
Articles manufactured.
Boxes, 19.
Candlestick, 214 (ill.), 33.
Cannel coal articles, 28.
Double sheets of metal, tankards said to be made from, 77.
Range of, 14, 28, 30, 40.
Saucepan (ill.) 32.
Biographical details, scantiness of records, etc., 26-7.
Bradbury, Thomas, & Sons' predecessors (M. Fenton & Co.), work for, 15.
Date of beginning manufacture of plated articles, 27.
Descendants, 29.
Directory of 1774 and 1787, description in, 15.
Discovery of fusion process generally attributed to, 28-9.
Dixon's, Charles, recollections, 30-1.
Longevity, 51.
Marks, 214, 441.
Master Cutler (1763-4), 27.
Offices held, 27.
Rolling metal for the trade, 15, 40, 109.
- Hancock, Rowbotham & Co.**—Members of first Association of Sheffield Silversmiths, 51.
- Hancock, Samuel**—Assay Master (1807), 464.
- Hancock, Simon**, 26.
- Hancock, W., and J. Rowbotham**—Mark for silver goods (1773), 472.
- Hancock, William**, 29, 433 *note*.
Registration at Goldsmiths' Hall, London, 38, 463.
- Hand Device**, 429, 431-3.
- Hand Rolls**, 108 (ill.), 109.
- Handles** to Teapots and Coffee pots, 354.
- Hanson, M.**—Mark (1810), 448.
- Harcastle, H.**, York, VIII.
- Hardesty, G.**—Mark for silver goods (1828), 485.
- Hardness**—Old Sheffield Plate, comparison with Electro-plate, 173.
- Hardy, Bell & Co.**—Mark for silver goods (1831), 485.
- Hardy, J.**—Mark for silver goods (1799), 480.
- Hardy, T.**—Mark for silver goods (1836), 486.
- Hare, Mr. H. S.**, Taunton, VII.
- Harker's Hotel, York**—Old Sheffield Plate in use, 56.
- Harris, Thos.**, Sheffield Engraver, 397.
- Harrison Bros. & Howson**—Marks for silver goods (1849), 488.
- Harrison, G.**—Marks (1823), 450.
- Harrison, J.**—Marks.
Plated goods (1809), 447.
Silver goods (1778), 474; (1844), 487.
- Harrison, J., & Co.**—Marks for silver goods (1833), 486; (1866), 492.
- Harrison, Mr. B. B.**, of Sevenoaks, VI.
Decadence of design evidenced by makers' catalogues, 396-7.
- Harrison, W. W. & Co.**—Marks for silver goods (1857), 489; (1861), 490; (1866), 492.
- Harwood, S.**—Mark for silver goods (1835), 486.
- Harwood, T.**
Marks, 246; (1816), 449.
Snuffers (ill.) 246.
- Harwood, W., & Co.**—Mark for silver goods (1801), 481.
"Hash Dishes," 283 (ill.), 284, 288, 289.
- Hatfield, A.**
Dessert knife and fork, close plate with carved white ivory handles (ill.), 457.
Mark (1808), 447.
- Hatfield, A., & Sons.**—Mark for silver goods (1823), 484.
- Hattersley**, "well-known London manufacturer," 146.
- Hawker, Isaac, & Son**, Birmingham—Glass supplied to M. Fenton & Co. and Watson & Bradbury, 68.
- Hawksley, G.**—Mark for silver goods (1858), 490.
- Hawksley, G., & Co.**—Mark for silver goods (1856), 489; (1864), 491.
- Hawksworth, Eyre & Co.**
Dies, destruction, etc., of, 59.
Mark for silver goods (1833), 486; (1867), 492; (1869), 493.
- Hawley, G.**—Mark for silver goods (1784), 476.
- Hawley, Mr. F. A.**, Hampstead, VII.
- Head, Mr. C. A.**, Hartburn Hall, near Stockton-on-Tees, VII.
- Heming & Co.**, London, VIII.
- Henderson, Jas.**—Dublin dealer supplied by Watson & Bradbury (1807-12), 153.
- Henfrey, J. & S.**—Mark for silver goods (1775), 473.
- Henfrey, John**—No marks used (1781), 443.
- Henfrey, Samuel**—No marks used (1781), 443.
- Hennell, S.**—Mark for silver goods (1828), 485.
- Hermann, And. Wilh.**, Hamburg—Customer of Watson & Bradbury (1798), 159.
- Hewitt, H., & H. Rock**—Mark for silver goods (1799), 480.
- Hewitt, James**—Dublin dealer supplied by Watson & Bradbury (1795-1805), 153.
- Heyman, S., & Co.**, Hamburg—Customers of Watson & Bradbury (1802), 159.
- Hibbert, G.**—Mark for silver goods (1834), 486.
- Hibernia mark** on Irish silver plate, 150, 466.
- Hill, D., & Co.**—Marks (1806), 446.
- Hill, Mr. Ernest**, Woking, VII.
- Hinchcliffe, J.**—Mark for silver goods (1799), 480.

- Hinks, J.**—Mark (1812), 448.
- Hipkiss, J.**—Mark (1808), 447.
- Hipwood, W.**—Mark (1809), 447.
- Hirst, Harry**, designs attributed to, 35.
- Hirst, John**—Registration at Goldsmiths' Hall, London, 38, 463.
- Hobday, J.**—Mark (1829), 450.
- Hobday, Samuel**—Patents for snuffers, 245, 247 (ill.), 246.
- Hobson, Mr. A. J., J.P.**, of Sheffield, VII.
- Hobson, Miss**, of Sheffield, VII.
- Hodgson, Thomas**, 437 *note*.
- Hogarth**—Tea-party group, 353.
- Holbrook, Mr.**, New York, VIII., 158.
- Holding Capacity**, Marks indicating, 440.
- Holdsworth, William**, Britannia Metalsmith—Mark (1800), 497.
- Holland**, Sheffield Plate in, 159.
- Holland, H., & Co.**—Mark (1784), 444.
- Hollow Jacketed Vessels**, 203-4 (ill.), 203, 204. Vegetable Dishes, 284 (ill.), 288.
- Holmes & Maplesden**, London, VIII.
- Holy, Daniel**, 59, 433.
- Holy, Daniel, & Co.**, 59, 397. History of firm, 433. Marks. Plated goods, none used (1781), 443. Silver goods (1776), 473; (1778), 474.
- Holy, D. & G.**—Marks (1821), 450 *and note*.
- Holy, Danl. & Geo., & Co.** Articles made by (ill.), 199, 266, 267, 287, 330, 332. Mark, 433.
- Holy, Danl., Parker & Co.** Articles made by (ill.), 204, 206, 297, 298, 314, 356. Mark (1804), 433, 445.
- Holy, Danl., Wilkinson & Co.** Articles manufactured by, illustrations, etc., 70, 206, 212, 213, 251, 255, 261, 272, 280, 284, 299, 308, 327, 333, 343, 353, 355, 367, 377. Irish connection, 153, 434. Mark (1784), 433, 444, 446 *note*. Shields, soldering in, 92.
- Holy, T., & W. Newbold**—Mark for silver goods (1774), 473.
- Honey Hives**, 198 (ill.), 389.
- Hoole, James**, "Pewterer," 501 *note*.
- Hoole, Mr. B.**, of Sheffield, VII.
- Hop Market Hotel, Worcester**—Old Sheffield Plate in use, 56.
- Horne, Dr. W. Jobson**, of London, VII.
- Horton, D.**—Mark (1808), 447.
- Horton, J.**—Mark (1809), 447.
- Hot Water or Shaving Pot** (ill.), 204.
- Houlden, J.**—Mark for silver goods (1825), 485.
- Hounsfield, B.**—Mark for silver goods (1831), 485.
- Howard & Hawksworth**—Mark for silver goods (1835), 486.
- Howard, Stanley & Thomas**—London firm of platers registered at Sheffield Office (1809), 145, 428. Marks (1809), 447.
- Hoyland, Clarbour & Barnard**—Marks for cutlery, (1787) 459.
- Hoyland, John.** Cake basket made by (ill.), 205. Mark, 214.
- Hoyland, John & Co.** Articles made by (ill.), 88, 220, 255, 308, 329, 341, 466. Marks. Plated goods. Mark used before 1773, 441. No marks used in 1774, 442. Silver goods (1773), 472. Members of first Association of Sheffield silversmiths, 51.
- Hoyland, T.**—Mark for silver goods (1776), 473.
- Hoyland, W., & Co.** Mark for silver goods (1777) 474. Silver handled knife and fork, (ill.) 456.
- Hughes & Fearon**, Birmingham—Glass supplied to M. Fenton & Co. and Watson & Bradbury, 68.
- Hughes & Harris**, Birmingham—Glass supplied to M. Fenton & Co. and Watson & Bradbury, 68.
- Hughes, Col., C.B.**, of Sheffield, VII.
- Hughes, Danl., & Co.**, Birmingham—Glass supplied to M. Fenton & Co. and Watson & Bradbury, 68.
- Hukin & Fenton**—Mark for silver goods (1856), 489.
- Hunt, A.**—Mark for silver goods (1822), 484.
- Hunt, Mr. H.**, VII.
- Hunter & Twigg**—Marks for cutlery (1787), 459.
- Hunter, M., & J. Twigg**—Marks for silver goods (1781), 475.
- Hunter, late Mr.**—Recollections of Joseph Hancock, 27.
- Huntsman, Benjamin**—Experiments with cast steel, 75, 494.
- Hutchinson, W. & H.**—Mark for silver goods (1837), 487.
- Hutton, Dr.**, of Birmingham, 438.
- Hutton Family**, 438-9.
- Hutton, Mr. Herbert**, of Sheffield, VII.
- Hutton, Mrs.**, Chapel for workpeople built by, 10.
- Hutton, W.** Marks. Plated goods (1807), 439, 446; (1831), 451; (1837), 451; (1839), 451; (1849), 452. Silver goods (1836), 486. Meat fork by (ill.) 8.
- Hutton, W., & Son**—Mark for silver goods (1857), 489.
- Hutton, William, & Sons.** Antiquity of business, 438, 439. Argentine, use of, for manufacture of spoons and forks, 338. Existing business, premises, etc., 439. Marks. Electro-plate, 437. Silver goods (1866), 492. Silver plate works, site of, 15.
- Hutton, William Carr**, Close plating business in Sheffield—Advertisement (1833), 439.
- Hyde & Nevins**, New York—Customers of Watson & Bradbury (1816-9), 157.

I

- Ibberson, J.**—Mark for silver goods (1774), 473.
- Ice Pails or Wine Coolers**, *see* Wine Coolers.
- Illustrations.**
 Number of makers' names appearing, explanation of small number, 202-3.
 Size, relation to dimensions of articles, 202.
for illustrations of articles, processes, etc., *see* separate list.
- Ince, C.**, Newport, VIII.
- Inches, Mr. E. J.**, Edinburgh, VII.
- Infirmiry, Sheffield**—Old Sheffield Plate, 2.
- Ingall, George.**—Member of firm of Roberts, Cadman & Co. (1786), 44.
- Initials, Names, etc.**, taken from Marks, *see* Separate list.
- Inkstands**, 297-8 (ill.), 297, 298-300.
 Illustrated designs from catalogues (about 1789), 411.
- Inn Proprietors**, Silver and Old Sheffield Plate owned and used by.
 Act of 1696, 55 *note*.
 Demand for Old Sheffield Plate, 54.
 Hotels, etc., still possessing and using Old Sheffield Plate, 55-6.
 Solid silver plate, 54-5, 56.
- Inscriptions**, *see* title Crests, Monograms, Inscriptions, etc.
- Interchangeable Articles**, *see* title Combined and Interchangeable Articles, *also* names of Articles.
- Interlaced Wire-work patterns**—Period of production, 185.
- Invoices**, Original Invoices (ill.), 199.
- Ireland.**
 Amount of Old Sheffield Plate in Ireland, 147-54.
 Articles specially manufactured for, 151.
 Close plating, workmen imported for, 150.
 Demand for Old Sheffield Plate, 152-4.
 Effect on trade of silversmiths, 150.
 List of dealers in Dublin, 1795-1813, from ledgers of Watson & Bradbury, 153-4.
 Retail firms in Dublin, 148.
 Duty on silver plate, 150, 466.
 English fashions, improvements, etc., efforts of Irish silversmiths and retailers of silver plated goods to keep pace with, 148-50.
 Foreign country, treatment as, by First Association of Sheffield Silversmiths, 51.
 Glass supplied from, question of, 67, 69.
 Manufacture of fused plated wares, extent of, 148, 150-1.
 Reasons for non-establishment of industry, 151-2.
- "**Irish Dish Rings**," 276 (ill.), 278, 279.
- Irish National Museum**, Art and Industrial Division of, VII.

J

- Jack, A., & Co.**, Cheltenham, VIII.
- Jahn, Mr. A. C. C.**, of the School of Art, VII.
- James, Mr.**, of Leeds, VII.
- Janillion and Fagan**—Dublin dealers supplied by Watson & Bradbury (1799), 153.
- "**Janty**,"
 Mark 171.
 Plain Dish and cover made by (ill.), 164.

- Jarvis, Mr. J. H.**, of Richmond, VIII.
- Jervis, J.**—Mark for silver goods (1775), 473.
- Jervis, W.**—Marks.
 Plated goods (1789), 445.
 Silver goods (1789), 477.
- Jervis, William**, Bath and White Metal Cutler, 495.
- Jessop, W.**—Mark for silver goods (1796), 479.
- Jessop, William, & Sons**, of the Brightside Works, Sheffield, 59.
- Jewesson, R.**—Mark for silver goods (1800), 480.
- Johnson, J.**—Mark (1812), 448.
- Johnson, E.**, Dublin, VIII.
- Johnson, Thos.**—Dublin dealer supplied by Watson & Bradbury (1812), 153.
- Johnstone, Mr. Alfred S.**—Notes explanatory of the supplanting of copper by German silver, 138-9.
- Johnstone, Mr. Alfred T.**, Ridnal, Worcestershire, VII.
- Joints or Hinges**, Dies used for, 61, 62.
- Jones**—Mark (1824), 450.
- Jones, I. & M.**, Edgbaston Street, Birmingham—Glass supplied to M. Fenton & Co. and Watson & Bradbury, 68.
- Jones, J., H. Greenway & Co.**—Mark for silver goods (1783), 475.
- Jones, Robert, & Sons**, Liverpool, VIII.
- Jones, Smart & Co.**, Birmingham—Glass supplied to M. Fenton & Co. and Watson & Bradbury, 68.
- Jordan, T.**—Mark (1814), 448.
- Judging Old Sheffield Plate**—Tests, etc.
 Colour, 173.
 Hardness, 173.
 Mellowness of appearance, 175.
 Re-plating, difficulty caused by, 173.
- Jugs or Pitchers**, 305 (ill.), 306-8.
 Cream Jugs, *see* that title.
 Milk Jug (ill.) 344.
 Mounted Staffordshire Ware, 338 (ill.), 339-40.
 Sheffield Plate and silver jugs (1775-60) (ill.), 32.
 Top and lip protected with plated drawn wire mount (ill.), 86.
- Justice, P.**—Mark for silver goods (1774), 473.

K

- Kavanagh, Jno.**—Dublin dealer supplied by Watson & Bradbury (1795-1813), 153.
- Kay, J.**—Mark for silver goods (1804), 481.
- Kay, John, & Co.**
 Articles made by (ill.), 392.
 Mark on silver goods (1795), 479.
- Keene, John, Mrs. Jane & Wm.**—Dublin dealers supplied by Watson & Bradbury (1795-1812), 153.
- Kelk, C.**—Mark for silver goods (1775), 473.
- Kemp & Wilcox**, Wolverhampton, VIII.
- Kemp, J.**—Mark for silver goods (1779), 474.
- Kent, William**—Chamber candlestick patent, 245.
- Kettles on Stands with Lamps**, number of patterns, etc., 301 (ill.), 169, 301-2.
- Kid, Robert**, Philadelphia—Customer of Watson & Bradbury (1816), 157.
- King, John**—Candlestick patents, 247.

- King's Head, Cirencester**,—Old Sheffield Plate in use, 56.
- Kinman, Mr. G.**—Manager at T. Bradbury & Sons' Works, VII, 98 *note*.
- Kippax & Nowill**, 460.
Marks—None used (1781), 443.
- Kippax, R., & Co.**—Marks for silver goods (1774), 473.
- Kirk, Joseph**—No marks used (1774), 442.
- Kirkby, J.**—Mark for silver goods (1800), 480; (1809), 482.
- Kirkby, J., Gregory & Co.**
Articles made by (ill.), 462.
Mark for silver goods (1822), 484.
- Kirkby, J., J. Waterhouse and J. Hodgson**—Mark for silver goods (1808), 482.
- Kirkby, Mary**—Mark for silver goods (1780), 474.
- Kirkby, S. & W.**—Mark for silver goods (1821), 484.
- Kirkby, Samuel**, 437 *note*.
Marks (1812), 438, 448.
Workmanship, 438.
- Kirkby, Samuel & Co.** (afterwards Kirkby, Waterhouse & Co.)
Articles made by (ill.) 185, 207, 208, 342, 351, 384, 438.
Marks.
Plated goods, 438.
Silver goods (1784), 476; (1796), 479.
- Kirkby, Smith & Co.**—Britannia Metalsmiths.
Britannia Metal plated articles, 496.
Mark (1797), 497.
Tea caddy (ill.), 498.
- Kirkby, Waterhouse & Co.**
Articles made by (ill.), 199, 208, 209, 260, 286, 288, 365, 383, 385.
Mark for silver goods (1793), 478; (1818), 483.
Registered as silversmiths (1793), 435.
- Kitchen & Walker**—Mark for silver goods (1835), 486.
- Kitchen, T.**—Mark for silver goods (1810), 482.
- Kitchen, Walker & Curr.**
Articles made by (ill), 250, 325.
Mark for silver goods (1832), 486.
- Knife Boxes**, Chippendale and Sheraton designs, 377.
- Knife, Fork and Spoon Tray**, 269 and ill.
- Knitting Sheath or Bodkin holder** (ill.), 393.
- Knobs of teapots, coffee pots, etc.**, 354.
- Knowles, J., & Son**—Mark for silver goods (1860), 490.
- Knox, John**—Advertisement in "Belfast Newsletter," (1791), 149.
- L**
- Labels**, Decanter and Wine Labels (ill.), 253, 303.
Illustrated designs from catalogues (1770-90), 399.
- Lake, J. E., & Son**, of Exeter, VIII.
- Lake, Mr. J. H. Ellett**, of Exeter, VII.
- Lambert**, London, VIII.
- Lambert, Mr. George**, of London, VII.
- Lambert, William**, 60.
Mark for cutlery (1774), 458.
- Lamborn, T.**—Mark for silver goods (1776), 473.
- Lamerie, Paul.**
Designs of, 186 (ill.), 187.
Pierce-work in silver, 188.
- Lamps.**
Arganda lamp (ill.), 395.
Coach lamp at Knole Park, Sevenoaks (ill.), 394.
Shaving Lamp (ill.) 391.
Wick-raising patents, 395.
- Large & Hodgetts**, Dudley—Glass supplied to M. Fenton & Co. and Watson & Bradbury, 68.
- Large, Wm.**, Dudley.—Glass supplied to M. Fenton & Co. and Watson & Bradbury, 68.
- Largest Articles**—Period of production, 185 *note*.
- Law, J., Atkin & Oxley**, 34.
Mark for silver goods (1824), 484.
- Law, John.**
Death in 1819, 34.
Mark for silver goods (1790), 477.
- Law, John, & Son.**
Mark (1807), 446.
Successors, 34.
- Law, Joseph**—Mark for silver goods (1824), 484.
- Law, R.**—Mark (1807), 446.
- Law, Thomas**, 34.
Apprentices.
Fenton, Matthew, junr., 38.
Roberts, Samuel, 38.
Articles made by, illustrations, etc., 189, 194, 220, 232, 250, 338 *note*, 346, 347, 425, 454.
Box-making enterprise of Cutlers' Company, share in, 19.
Marks.
Cutlery (1774), 458.
Plated goods, (before 1773), 425, 441.
Silver goods (before 1773), 472.
- Law, Thomas, & Co.**, 397.
Articles made by, illustrations, etc., 2, 150, 151, 223, 227, 261, 273, 275, 284, 315, 327, 334, 336, 338, 339, 340, 344, 351, 362, 384, 389, 392.
Confusion with William Law, retail firm of Dublin, 148, 454.
Marks.
Cutlery (1787), 459.
Plated goods.
1781—None used, 443.
1784, 444.
Members of first Association of Sheffield Silversmiths, 51.
- Law, Wm.**—Dublin dealer supplied by Watson & Bradbury (1795-1812), 153.
Confusion with Thomas Law & Co., 148, 454.
- Laycock, Thomas**, Cutler (1774), 458.
- Lea, A. C.**—Mark (1808), 447.
- Leader, Daniel**, 35, 36.
Mark for silver goods (1797), 480.
- Leader Family**—Literary and political work, 59.
- Leader, Mr. R. E.**, VI.
Boulsover's appreciation of his discovery, 16.
Carr's, Richard, diary, account published, 461.
Glass—Sources of supply in 18th century, 69.
- Leader, Thomas.**
Longevity, 51.
Partnership with Henry Tudor, 34—Retirement, 36.
- Leader, Thos. and Danl.**,—Mark for silver goods (1798), 36, 480.
- Ledbetter, J. E.**, Dublin, VIII.

- Lee & Large**, Dudley—Glass supplied to M. Fenton & Co. and Watson & Bradbury, 68.
- Lee & Middleton**—Mark for silver goods (1840), 487.
- Lees, G.**—Marks (1811), 448.
- Lees, Thomas**—Patent for improvements in snuffers, 247.
- Leg of Mutton Holder** (ill.), 392.
- Leighton, S.**, Lancaster, VIII.
- Lemon Strainer** (ill.), 393.
- Lemuel, Wells & Co.**, New York—Customers of Watson & Bradbury (1806-7), 157.
- Leonard, P.**—Mark for silver goods (1835), 486.
- Lepard**—Paper supplied for catalogue (1794), 397.
- Letting in Shields**, *see* Shields.
- Levesley Bros.**—Mark for silver goods (1863), 491. (1868), 493.
- Levrat of Paris.**
Mark 171.
Wine glass holder or fruit dish (ill.), 163.
Workmanship, 170.
- "**Liekup**," 105.
- Lilly, John**—Mark (1815), 449.
- Lilly, Joseph**—Mark (1816), 449.
- Lindley, J., & Co.**—Mark for silver goods (1788), 477.
- Lindley, William**—Mark, 147 *note*.
- Linley, W.**—Mark for silver goods (1797), 480.
- Linwood, J.**
Marks (1807), 446.
Skewer by (ill.) 8.
- Linwood, M., & Sons.**—Mark (1808), 447.
- Linwood, W.**—Mark (1807), 446.
- Lion Hotel, Guildford**—Old Sheffield Plate in use, 56.
- Liquor Frames.**
Demand and price, decline in, 304.
Illustrations of various designs, 199, 304, 305.
Sale room values, 184.
- Lists of Articles** made in Old Sheffield Plate.
Gales and Martin's Directory (1787), 196.
Sketchley's, J. & T., Directory (1774), 196.
Watson & Bradbury, articles manufactured by (1788-1815), 196-7.
- Littlewood, John.**—Marks.
Cutlery (1774), 458; (1787), 459.
Plated goods (before 1773), 441; (1781)—No marks used, 443.
Silver goods (1773), 472.
- Littlewood, Jonathan**—Mark for silver goods (1773), 472.
- Lloyd, John**, of Harold's Cross, Dublin, Plated goods made by, 148.
- Locality of manufacture**, 145-72.
- Lockwood Bros.**—Mark for silver goods (1855), 489.
- London.**
Cutlers of—
Heavy hollow silver handles, method of manufacture, etc., 455.
Quality of silver used for plating, enactment of 1379, 4.
Jewellers, retail firm of (now defunct), marks on Sheffield Plate indicating proportion of silver used, 79.
Makers of Old Sheffield Plate, names given as—
Agents, dealers or jobbing workers, 146.
- London—Continued.**
Reproductions or "fakes," manufacture of, 174.
Detection, means of, 175.
Silver Assay mark found on Winter, Parsons & Hall's candlesticks, 219.
Silversmiths.
Decorations and designs, Sheffield fashions followed, 45, 188.
Hammering, method of, 129.
Individuality of work, comparison with work of Sheffield platers, 396.
Influence on design in Sheffield—Inkstands, 297.
Marks—Influence of Sheffield Assay Office Acts, 470.
Salt cellars—Price compared with price of Sheffield made silver salt cellars, 309.
- London Hotel, Exeter**—Old Sheffield Plate in use, 55.
- Louis XVI.**—Support given to French fused plated industry, 168.
- Love, John, or J. (I.) Love & Co.** (Love, Silverside, Derby & Co.)
Articles made by (ill.), 311, 312, 338 *note*, 346, 347, 389.
Marks.
Plated goods (1785), 437, 445.
Silver goods (1783), 476.
- Loving Cups** (ill.), 150, 348, 349, 351.
- Lowe & Sons**, Chester, VIII.
- Lowe, T. P.**—Mark for silver goods (1840), 487.
- Lownes, Edward**, Philadelphia—Customer of Watson & Bradbury (1822-4), 157.
- Loy, R.**—Marks for silver goods (1792), 478.
- Lübeck**, Sheffield Plate exported to, 159.
- Ludemann, Andreas D.**, Hamburg—Customer of Watson & Bradbury (1803-4), 159.
- Lurasco Bros.**, Amsterdam—Customers of Watson & Bradbury (1802), 159.
- Lyne, Mr. F.**, of Bristol, VII.
- Lyon, M. & S.**, London, VIII.
- Lysippus**, Warwick Vase attributed to, 380.

M

- McClellan & Hull**—Dublin dealers supplied by Watson & Bradbury (1807-9), 154.
- McClean, John**—Advertisement in "Belfast Newsletter." (1785), 149.
- Maces** (ill.), 388.
"Faked" piece (ill.), 177.
- McFarlane, John**, Boston—Customer of Watson & Bradbury (1810), 157.
- Mackay & Chisholm**—Mark for silver goods (1861), 490.
- McMullin, John**, Philadelphia—Customer of Watson & Bradbury (1807-11), 157.
- Madin & Trickett** (Madin & Trickett).
Articles made by (ill.), 392, 456.
Marks.
Cutlery (1774), 458.
Old Silver cutlery (1779), 455.
Plated goods, no marks used (1781), 443.
Silver goods (1779), 474.

Madin, F., & Co.—Mark (1788), 445.

Madin, P., & R. Trickett—Mark for silver goods (1781), 475.

Makers of Old Sheffield Plate.
Early makers, 25-51.
Lists with marks, etc., 441-52.
Manufacturers' numbers, 440.
for particular makers, *see* their names.

Makin, E. J.—Mark for silver goods (1867), 492.

Makin, J.—Mark for silver goods (1786), 476.

Makin, J., & Co.—Mark for silver goods (1798), 480.

Mallett, Mr. Francis, Bath, VII.

Mallinson, B., & Son, Huddersfield, VIII.

Mammatt, Buxton & Co.—Mark for silver goods (1865), 491.

Manly, Jas.—Dublin dealer supplied by Watson & Bradbury (1807-9), 154.

Manning, J. & H.—Dublin dealer supplied by Watson & Bradbury (1797-1804), 153.

Manor, Sheffield—Captivity of Mary, Queen of Scots, 2.

Mappin & Webb, London, VIII.

Mappin Bros.—Marks.
Plated goods (1850), 452.
Silver goods (1859), 490 ; (1867), 492.

Mappin & Co.—Mark for silver goods (1860), 490.

Mappin & Son—Mark for silver goods (1848), 488.

Mappin, J.—Mark for silver goods (1775), 473.

Mappin, J., & Co.—Mark for silver goods (1775), 473.

Mappin, Jonathan—No marks used (1781), 443.

Mappin, Joseph, & Bros.—Mark for silver goods (1856), 489.

Mappin, Joseph, & Son—Mark for silver goods (1833), 486.

Mappin, Sir F. T., Bart., M.P., 59.

Mappin, Webb & Co.—Mark for silver goods (1864 & 1865), 491.

Mapplebeck & Lowe.
Mark 452.
Snuffer tray (ill.), 328.

Margrave, J., & Co.—Mark for silver goods (1773), 472.

Margrave, Marsden & Brocklesby—No marks used (1774), 442.

Markland, W.—Mark (1818), 449.

Marks, Assay Office Marks, *see* Assay Office.

Marks, Makers' Marks.
Britannia Metal makers (1787-1837), 497.
Cutlers, 455-460.
Electro-plate—Modern firms using marks, 430.
Holding capacity, marks indicating, 440.
Old Sheffield Platers.
Act of 1773, prohibition by, 309, 426.
Act of 1784, provisions of, 426.
Assay marks on sterling silver, marks resembling, 425, 440, 460.
Foreign manufacturers' marks, 170-172.
Gauge of plated metal, marks indicating, 78-9—France, 170.
Interest and importance of marks, 425.
List of makers and their marks (chronological), 441-52.
Manufacturers' numbers, 440.
Merchant or retailer, marks struck for—
Contravention of Act, 429.

Marks—Continued.

Old Sheffield Platers—Continued.
Miscellaneous untraced marks—List, 452.
Number registered (1784-1836), 427.
Birmingham and Sheffield makers, comparison of numbers registered, 428.
Scarcity—Explanation, 427.
Size difficulty, 430.
Workmen's marks, 440.
Pewterers, 501.
Sheffield silversmiths, 470.
Different marks registered by one firm in same year, 470.
Explanation of irregularities, 470-1.
List of date letters, etc., 467-9.
List of makers marks (1773-1869), 472-93 ; also silversmiths' and cutlers' marks, 453-60.
Overmarking by London silversmiths, 189-90. (ill.), 190.
Retailers' initials, confusion caused by, etc., 471-2.
Variety of forms of punches used without registration, 470.
Variety used—Indication of variety of industries followed by one maker, 458.
for particular makers, *see* their names.

Marples, T.—Mark for silver goods (1855), 489.

Marquand, Frederick, Marquand & Barton, Marquand & Bros., Marquand & Co.—Successors of Erastus Barton & Co., 158.

Marquand, Isaac, New York—Customer of Watson & Bradbury (1824), 157.

Marriott, L.—Mark for silver goods (1787), 477.

Marsden, W.—Mark for silver goods (1774), 473.

Marsden, William—No marks used (1774), 442.

Marsden, W., & Co.—Mark for silver goods (1773), 472.

Marsh, J.—Mark for silver goods (1793), 479.

Marshall, Geo., of Spanish Town, Jamaica—Customer of Watson & Bradbury (1795-1801), 158.

Martin & Co., Cheltenham, VIII.

Martin, B.—Mark for silver goods (1820), 484.

Martin Bros. & Co.—Mark for silver goods (1846), 488.

Martin, D.—Sheffield Engraver, 397.

Martin, Hall & Co.—Mark for silver goods (1854), 489 ; (1863), 491.

Mary Queen of Scots—Captivity in Sheffield, 2.

Matches, Date of Introduction, 374.

Materials used in manufacture of Old Sheffield Plate, early trade prices, 61.

Matthews, Rev. J., of Broxbourne, VII.

"**Maundrills**," 106 (ill.), 107.

Mearbeck, S.—Mark for silver goods (1812), 482.

Meat Plates, *see* Plates.

Mellowness of appearance due to age—Test of antiquity, 175.

Mercurial or fire-gilding, 71 (ill.), 72, 189.

Meredith, H.—Mark (1807), 446.

Merry—Patent for plating silver by fusion on to German silver, 138.

Mertz, C., Amsterdam—Customer of Watson & Bradbury (1802), 159.

Methods of Plating.
Oldest methods, 4-8.
see also names of processes, Close plating, French plating, Fusion plating.

- Micklethwaite, J., and J. Hounsfeld**—Mark for silver goods (1786), 476.
- Middleton, Jewesson & Co.**—Mark for silver goods (1798), 480.
- Middleton, T., Rd. Jewesson, G. Ashford and G. Frost**—Registration as silver plate workers (1798), 452 *note*.
- Miscellaneous Pieces**, 387 (ill.), 387, 388-95.
- Mitchell, Joseph**, 25.
- Mitchell, Mr. S.**, 22.
- Mitchell, Thomas**—Joseph Hancock's apprenticeship with, 26.
- Mitchell-Withers, Mr. J. B.**, of Sheffield, VII., 25.
Boulsover—Spelling of name, 9 *note*.
- Mogg, J. H.**, Bristol, VIII.
- Molyneux, Jos.**—Dublin dealer supplied by Watson & Bradbury (1808-11), 154.
- Monograms** *see* Crests, Monograms, Inscriptions, etc.
- Montagu, Hon. Mrs.**—Admiration for Matthew Boulton, 50.
- Monteith or Wine Glass Cooler**, 189 (ill.), 189, 383.
- Montgomery**—Proprietor of "Sheffield Iris," 44.
- Moore, Ambrose**—Dublin dealer supplied by Watson & Bradbury (1795-6), 154.
- Moore, F.**—Mark (1820), 449.
- Moore, J.**—Marks.
Plated goods (1784), 444.
Silver goods (1795), 479.
- Moore, R.**—Irish agent of Roberts, Cadman & Co., 150.
- Morgan, Thos. & Wm.**—Dublin dealers supplied by Watson & Bradbury (1806-12), 154.
- Morton & Co.**, Articles made by (ill.), 228, 233, 238, 327.
- Morton & Milroy**—Edinburgh jewellers supplied with Old Sheffield Plate by Watson & Bradbury, 154.
- Morton, F.**—Mark for silver goods (1820), 484.
- Morton, Richard**, 40.
Articles made by (ill.), 272, 462.
Boulton, Matthew, relations with, 49, 145.
Marks, 441.
Plated goods (before 1773), 441; (1780), 42.
Silver goods (1773), 41, 472; (1780), 475.
Telescopic candlesticks—Morton's patent, 216.
- Morton, Richard, & Co.**
Articles made by, illustrations, etc., 88, 185, 206, 211, 238, 255, 256, 281, 291, 293, 307, 310, 311, 326, 341, 342, 431, 466.
Marks.
Plated goods.
1774—No marks used, 442.
1785, 431, 445.
Silver goods (1773), 41, 472; (1781), 475.
Members of first Association of Sheffield silver-smiths, 51.
Telescopic candlesticks, patent for, 216.
- Morton, Thomas**—No marks used (1774), 442.
- Morton, W.**—Mark for silver goods (1869), 493.
- Morton, Warris & Co.**, 431.
- Mortons**—Early connection with Sheffield Plate industry, 31, 40.
- Mosley, Samuel**, 42.
- Motley, Thomas**—Candlestick and Candle Patents, 247.
- Moulton, Eben.**, Boston—Customer of Watson & Bradbury (1807-16), 157.
- Mounted Staffordshire Ware**—Vases, mugs, jugs, etc., 338 (ill.), 339-40.
- Mounts**, (ill.) 76, 77, 80, 85, 86.
Back to back method of strengthening 76-8 (ill.), 83.
Candlesticks—Designs, 215.
Decorations of different periods, 185.
Vogue of decorations introduced by Sheffield makers, 188.
Outer edge lapped over piece of iron wire for strengthening, 125-6 (ill.), 126, 279.
Salvers and Trays.
Three methods of treating borders (ill.), 83.
Tray plate, mounts for (ill.), 136.
Variety of designs, 316.
Selection of mounts from dies (ill.), 124.
Silver mounts, method of filling mounts, etc., 82-4.
Soldering, methods of, 122-5.
- Muffineers or Pepper Pots** (ill.), 315.
- Mug** (ill.) 339.
- Mullen, Michl.**—Dublin dealer supplied by Watson & Bradbury (1812), 154.
- Murphy, Bryan & Richd.**—Dublin dealers supplied by Watson & Bradbury (1799-1812), 154.
- Mustard Pots and Mustard Tankards.**
Bodies, method of raising, in early period, 62.
Britannia Metal (ill.), 498.
Dies—Prices, 61.
Illustrated designs from catalogue (about 1789), 411; (1804), 415; (1848), 423.
Illustrations of various designs, 314.
Number of patterns, prices, etc., 309.
Pierced specimens, advance in price, 184.
Sheffield-made silver, 309.

N

- Nairne, Mr. J. G.**, of the Bank of England, VII.
Forged coins, notes on, 395.
- Napoleon I.**—Desire to possess the Warwick Vase, 381.
- Navarro, Mr. A. F. de**, VII.
- Naylor & Settle**—Mark for silver goods (1778), 474.
- Naylor, Rev. Benjamin**—Capital furnished to Roberts & Cadman, 44.
- Needham, C.**—Marks.
Plated goods (1821), 450.
Silver goods (1810), 482.
- Needham, J.**—Mark for silver goods (1848), 488.
- Neill, S. D.**, Belfast, VIII.
- Nelson, Lord.**
Old Sheffield Plate inkstand presented to, 297.
Wine Cooler in silver presented to (ill.), 382.
- Newbould, George H.**—Agent of T. Bradbury & Sons in America, 156, 157.
- Newbould, W. & Son**—Mark (1804), 446.
- Newton, J., & Son**—Mark for silver goods (1829), 485.
- Nicholds, J.**—Mark (1808), 447.
- Nichols, George**, Sheffield—Glass supplied to M. Fenton & Co. and Watson & Bradbury, 67, 69.
- Nicholson, Mr. A.**, of the Sheffield Assay Office, VII.
- Nicholson, Mr. Alfred**, 45.
- Nicholson, Samuel**, 36.

Nicholson, Thomas, 45-7, 116, 397, 438.
 Boulsover's representative, story of, 14.
 Design, genius for, 45.
 Electro-plating, interest in, 47.
 Factory (ill.), 46.
 German silver, plating on, 47, 138.
 Longevity, 51.
 Portrait, 46.

Nixon, T., & Co.—Mark for silver goods (1808), 482.

Norris, H. E., Cirencester, VIII.

Norris, Richd., Baltimore—Customer of Watson & Bradbury (1810), 157.

North, J.—Mark for silver goods (1858), 490.

Nottingham—Making of articles from fused plate, 146-7.

Nowill, Joseph, 460.
 Marks.
 Cutlery (1774), 458.
 Silver goods (1783), 476; (1813), 460, 482.

Nowill, Mr. Sidney, of Sheffield, VII.

Nowill, J. & W.—Mark for silver goods (1825), 485.

Nowill, T.—Marks for silver goods (1786), 476; (1790), 477; (1800), 481.

Nowill, W. & J.—Mark for silver goods (1825), 485.

Nowlan, John—Dublin dealer supplied by Watson & Bradbury (1812), 154.

Numbers, manufacturers' numbers, 440.

Nutmeg grater, pocket (ill.), 390.

O

Oakes, 37.

Object and scope of work, V.

O'Donoghue, J. & C., Torquay, VIII.

Ogden, Jonathan, New York—Customer of Watson & Bradbury (1795-1803), 157

Old Park Silver Mill established by Joseph Hancock 15

Old Silver, *see* Silver.

Oldham, Thomas—Maker of articles from fused plate in Nottingham, 146-7.
 Mark (1860), 452.

Omelet Pan—Illustrated design from catalogue (about 1848), 423.

Ordinances, Early Ordinances fixing quality of silver used in plating, value of articles to be plated, etc., 4.

Osborn & Elliott—Mark for silver goods (1843), 487.

Osborne & Keville—Dublin dealers supplied by Watson and Bradbury (1804-9), 154.

Osborne, Wm.—Dublin dealer supplied by Watson & Bradbury (1803-13), 154.

O'Shea, Mr. L. T., of Sheffield University, VII., 500 *note*

Oswin & Co., Hereford, VIII.

Oval Shape, introduction of, 185.

Overmarking of Sheffield-made silver candlesticks by London silversmiths 189-90, (ill.), 190.

Owen, R., & Son—Mark for silver goods (1788), 477.

Oxford, Countess of—Visit to Sheffield and purchase of "Coal Ware," 28.

Oxidation, liability of German silver to, 139 (ill.), 144.

Oxley, John—Mark for silver goods (1841), 487.

Oxley, William—Wages for Die-sinking, 61.

P

Padley, Parkin & Co.—Marks.
 Plated goods (1849), 432, 451.
 Silver goods (1846), 488.

Padley, Staniforth & Co.—Mark for silver goods (1857), 489.

Page, Keen & Page, Plymouth, VIII.

Paget, A., Cheltenham, VIII.

Palmer, William—Patent for making and holding Candles, 247.

Parish Church of Sheffield—Old Sheffield and Silver Plate, 1.

Parker, Wm.—Dublin dealer supplied by Watson & Bradbury (1799-1802), 154.

Parkin & Marshall—Marks for silver goods (1866), 492.

Parkin, J. & A., Wigham—Mark for silver goods (1792), 478.

Parkin, T.—Mark for silver goods (1791), 478.

Parkin, W.—Mark for silver goods (1817), 483.

Parkin, W.—Britannia Metalsmith.
 Candlestick (ill.), 499.
 Mark (1821), 497.

Parsons, John—Partners, etc., 42.

Parsons, John, & Co., 42.
 Articles made by, illustrations, etc., 2, 190, 224, 225, 226, 227, 228, 235, 236, 298, 390, 397.
 Marks.
 Plated goods (1784), 434, 444.
 Silver goods (1783), 476.
 Silver handled cutlery, 455.

Parsons, Mary, Charity founded by, 2.

Parsons, Mr. A. M., of London, VII.

Partnerships—Complications of old Partnerships, 41, 42.

Patch Boxes, 19 (ill.), 21.

Patten, W.—Mark for silver goods (1780), 475.

Pawson, Mr. H., of Sheffield, VI.

Peacock, J., & G. Austin—Mark for silver goods (1798), 480.

Peake—Mark (1807), 446.

Pearson, R.—Mark (1811), 448.

Pegge, Strelley, of Beauchief Hall—Loan to T. Boulsover, 14.

Pelletreau & Upson, New York—Customers of Watson & Bradbury (1818-24), 157.

Pemberton & Mitchell—Mark (1817), 449.

Penton, George—Wick-raising patent, 395.

Pepper Pots or Muffineers (ill.), 315.
 Britannia Metal (ill.), 498.

Percolator or Strainer (ill.), 262, 393.

Percy, Earl—Order for close plated goods (1810), 7.

Percy's, Lady Idonea, Monument in Beverley Cathedral, 29.

Period of Production of Old Sheffield Plate, 1.

Peter, Walter—Dublin dealer supplied by Watson & Bradbury (1802-13), 154.

Petrie, James—Dublin dealer supplied by Watson & Bradbury (1810-12), 154.

Petz, Russian Maker—Mark, 162, 172.

- Pewter.**
 Britannia Metal, extent of resemblance to, 500.
 Collectors, increased interest in pewter, 501.
 Colour, 500.
 Date of earliest existence in Sheffield *and note*.
 Hall marks, copying by pewterers, 501.
 Ingredients—Variations in proportions, etc.,
 500 *and note*.
 Supersession by Britannia Metal, 497.
- Phoenix Device**, 435.
- Picksley, C., & Co.**—Mark for silver goods (1828), 485.
- Picksley's Show Rooms** in Sheffield.
 Advertisement (1828), 194.
 Illustration, 195.
- Pie Dish** (ill.), 288.
- Pierce working**, 118-21.
 Date of introduction, 118, 185.
 Fish slice, section of (ill.), 121.
 Fly-punching and piercing machine, method of
 working, 119, 121 (ill.), 119.
 Beds and Punches used in machine (ill.), 120.
 Lamerie's, Paul, designs, influence of, 186, 188.
 Originality shewn by O.S.P. makers, in adapting
 designs from silver ware and improving on
 them by the aid of dies, 188.
 Price of pierced articles, advance in, 184.
 Saw piercing, 118 (ill.), 118.
 Silver articles of Charles the First's time, 187.
- Pimley, S.**—Mark (1810), 448.
- Pinchbeck, Chrstr.**—Patents.
 Candlesticks, 245.
 Snuffers, 245 (ill.), 244, 246.
- "Pine, W. B."**
 Folding Pocket Ear Trumpet (ill.), 390.
 Mark 452.
- Pine-apple Device**, 433.
- Pinton, Mons.**, Paris, VIII., 164.
- Pipe Device**, 433.
- Pipe or Cigar Lighters**, 374 (ill.), 375.
 Taper Candlesticks used as, 256.
- Pitchers or Jugs**, *see* Jugs.
- Pitt or Globe Inkstand** (ill.), 298.
- Plate Cover**, made in Paris (ill.), 165.
- Plate Warmer**, 269 (ill.), 270.
- Plateaux or Stands**, *see* title Epergnes, Centre Pieces,
 etc.
- Plated Wire**, *see* Wire.
- Plater**—Misleading use of term in Old Directories, etc.,
 145.
- Plates**—Dinner and Meat Plates (ill.), 268, 270.
 Foreign made plate with silver mount, etc., (ill.),
 165.
 Plate or plate warmer, 269 (ill.), 270.
- Plating Furnace**, 66 and ill.
- Platt, Jacob S.**, New York—Customer of Watson &
 Bradbury (1816-7), 157.
- Plimmer, Mr. E.**, Surewsbury, VII.
- Polack, B.**—Mark for silver goods (1807), 481.
- Porringer** (ill.), 349.
- Porter, Dr. George**, Surbiton, VII.
- Pot à Sucre avec 12 Cuilliers autour** (ill.), 57.
- Potato Rings**, *see* Dish Rings or Rims.
- Poynton, J., & Co.**—Mark for silver goods (1804), 481.
- Poynton, T., & R. Flower**—Mark for silver goods (1801),
 481.
- Presentation Trowel** (ill.), 388.
- Preserve Dish** (ill.), 212.
- Price of Old Sheffield Plate.**
 Fluctuations almost unknown during period of
 production, 41.
 French Ware, 160.
 Sale room values, 182-4.
 Twenty-five years ago, 58.
- Prideaux, Mr. Walter**, of the Goldsmiths Hall, VII.
- Prime, J.**—Marks (1839), 451.
- Prime & Son**, Birmingham—First electro-plating
 machine, 140.
- Prior, T.**—Mark for silver goods (1778), 474.
- Processes, Practices and Inventions** 1, 71-97.
for details, see names of processes, etc.
- Proctor & Beilby**—Mark for silver goods (1792), 478.
- Proctor, C., & L.**—Mark for silver goods (1773), 472.
- Proctor, C., & T. Beilby**—Mark for silver goods (1795),
 479.
- Proctor, L., & Co.**—Mark for silver goods (1785), 476.
- Proctor, W.**—Mark for silver goods (1817), 483.
- Protective Tariffs**—Effect on export of Old Sheffield
 Plate, 58 *and note*.
- Pryor, Tyzack & Co.**—Mark for silver goods (1861), 491.
- Punching and Piercing Machine**, working of, 119, 121
 (ill.), 119.
 Beds and Punches used in machine (ill.), 120.
- Purchasers of Old Sheffield Plate**, Classes of, 54, 56, 57.

Q

- Quality of Sheffield Plate**, maintenance of, 41.
- Queen Anne Period Designs.**
 Popularity, 192.
 Scarcity of, in Old Sheffield Plate, 188.
 Teapots, 353.
- Quixall, J., & Co.**—Mark for silver goods (1803), 481.

R

- "R. & W."**—Candlestick (ill.), 226.
- R. C. & Co.**—Slide Candlestick, patent, 216 (ill.), 217.
- Raising by Hand**, 110-2 (ill.), 110, 112.
- Rallinson, Dollif**—Mark for silver goods (1790), 478.
- Rasch, A., & Co.**, Philadelphia—Customers of Watson
 & Bradbury (1819), 157.
- Rasch & Willig, Junr.**, Philadelphia—Customers of
 Watson & Bradbury (1819), 157.
- Rasch, William Antony**, New Orleans—Purchaser of
 Old Sheffield Plate, 156.
- Ratcliffe, T.**—Mark for silver goods (1778), 474.
- Raybold's Patent** for securing and holding Candles
 245.
- Read**, Dublin Cutler, 149 *and note*.
- Read, Taylor & Co.**, 158.
- Records**, Scantiness of, 98.
- Red Lion Hotel, Salisbury**—Old Sheffield Plate in use,
 56.
- Reed, Messrs. R. H., & Son**, Liverpool, VIII.

- Renovation, 178-81.**
 Care and skill required, 178.
 Class of pieces most easily renovated, 179-80.
 New appearance of restored article, cause of, 179.
 Standard silver, use recommended, 179.
 Teapots, difficulties with, 179.
- Repoussé Work or Chasing in High Relief, 72, 74.**
- Reproductions or "Fakes," 174.**
 Classes of goods most frequently reproduced, 175, 176.
 Detection, means of, 175-6, 178.
 Illustrations, 177, 181.
 Number offered for sale as compared with genuine pieces, 178.
 Price of genuine pieces, reluctance to pay—
 Plea advanced in justification of deception, 178.
 Sources of supply, 174.
 Tea Urns made by London copper and tin smiths during the Old Sheffield Plate period and subsequently electro-plated, 180-1 (ill.), 181.
- Resenhauer, Carl August Hamburg—**Customer of Watson & Bradbury (1800-6), 159.
- Revival of Industry.**
 Possibility of exact reproduction of Old Sheffield Plate, Cost, etc., 136-7.
 Prospects of, V.
- Rhodes Bros.—**Mark for silver goods (1855), 489.
- Rhodes, Ebenezer, Master Cutler (1808).**
 Hancock, Joseph, Boulsover's discovery attributed to, 28-9.
 Mark for silver goods (1791), 478.
- Rice, Edward—**Dublin dealer supplied by Watson & Bradbury (1795-1803), 154.
- Richards, Stephen, New York—**Customer of Watson & Bradbury (1824), 157.
- Richards, Taylor & Co.—**New York, Customers of Watson & Bradbury (1817-8), 157.
- Richards, Upson & Co., New York—**Customers of Watson & Bradbury (1801-16), 157.
- Rickatson, Mr. W. H., of London, VII.**
- Ridge, Mr. A. C., of Sheffield, VII.**
- Rigail & Roullaud, Amsterdam—**Customers of Watson & Bradbury (1802-4), 159.
- Roane's, Capt. George, advertisement (1711), 353 note.**
- Roberts & Belk.**
 Marks.
 Plated goods, 430.
 Silver goods (1864), 491; (1867), 492.
 Predecessors, 430 note.
- Roberts & Briggs (since 1863 Roberts & Belk)—**
 Marks.
 Plated goods (1860), 452.
 Silver goods (1859), 490.
- Roberts & Cadman, or Roberts, Cadman & Co. (afterwards Roberts, Smith & Co.), 43, 44.**
 Advertisement in "The Star," Dublin, (1824) 150
 Articles made by, illustrations, etc., 85, 86, 186, 189, 202, 216, 217, 218, 219, 229, 230, 234, 248, 252, 261, 283, 292, 294, 298, 314, 315, 327, 333, 344, 354, 366, 369, 372, 384.
 France and Spain, trade with, 58.
 Irish Agents, 150.
 Light and delicate work, 431.
 Marks.
 Plated goods (1785), 430, 431, 445.
 Silver goods (1786), 476.
 Silver threaded edges, introduction of, 82.
- Roberts & Hall—**Mark for silver goods (1847), 488.
- Roberts & Slater, 430 note.**
 Mark used on silver goods (1845), 488.
- Roberts, Clayton & Emory, or Roberts, Clayton & Co.**
 Articles made by (ill.), 256, 257.
 Mark for silver goods (1813), 483.
- Roberts, Dr. A. M., Southport, VII.**
- Roberts, Elam, Winter & Co., or S. Roberts & Co. 42.**
 Marks.
 Cutlery—none found, (1774), 458,
 Silver goods (1773), 472; (1781), 475.
- Roberts, Eyre & Co.—**No marks used (1781), 443.
- Roberts, Eyre, Beldon & Co., 38, 42.**
- Roberts Family—**Connections, etc., 40.
- Roberts, J.—**Mark for silver goods (1844), 488.
- Roberts, J., S. Moseley & J. Settle, or J. Roberts & Co.**
 Articles made by (ill.), 256, 257, 312, 313.
 Mark used for silver goods (1805), 481.
- Roberts, Jacob, 38, 40.**
- Roberts, Jacob, Junr., 40.**
- Roberts, Jacob and Samuel—**Marks.
 Cutlery (1774), 458; (1787), 459.
 Old silver handled cutlery (1765), 441, 455.
 Plated goods (before 1773), 441; (1786), 445.
- Roberts, John, 42.**
 Mark used on silver goods (1786), 477.
- Roberts, Mr. Leslie, of Sheffield, VII.**
- Roberts, Mr. Samuel, M.P., VII., 59.**
- Roberts, S., & Co. see Roberts, Elam, Winter & Co.**
- Roberts, Samuel, Senr., 38, 458.**
 Death in 1799, 40.
 Mark used on silver goods (1773), 472.
 Nicholson, Thomas, connection with, 45.
 Old Roberts and his workmen, 31.
 Partnerships in different firms, 41, 42.
- Roberts, Samuel (1763-1848), 31, 60.**
 Apprenticeship and establishment in separate business, 42-3.
 Benevolent activities, publications, etc., 44.
 Firm founded by, history of, 44.
 Influence on Sheffield silver trade, inventions, patents, etc., 42-4.
 Bright cut engraving, 86, 431.
 Close plating, improved patent for, 6.
 Folding toast racks, 43, 368.
 Plating German silver on copper and then fusing silver layer on result, 43, 137.
 Rubbing in silver shields, improvement on Wilks's method, alleged, 43, 93.
 Silver, proportion of, used—Attempt to increase proportion, 78.
 Silver edges, patent for dispensing with, 84.
 Silver edges, stamped silver filled feet, etc., 43, 82.
 Telescopic candlesticks and candelabra, 43, 185.
 Letter to local newspaper in 1843 describing activities and difficulties of the Old Sheffield Plate trade, 40.
 Longevity, 51.
 Marks.
 Cutlery—none found, (1774), 458.
 Plated goods, 43, 78.
 Portrait, 39.
 Wedgwood, friendship with, 194.
 Workmanship, 43.
refer also to title Roberts & Cadman or Roberts, Cadman & Co.

- Roberts, Samuel** (the third), 44.
- Roberts, Sidney**, 44.
- Roberts, Smith & Co.** (S. Roberts, Smith & Co., successors of Roberts, Cadman & Co.), 44.
Articles made by (ill.), 243, 301, 306, 323, 334.
Marks.
Plated goods (1828), 450.
Silver goods (1826), 485.
- Robinson & Co.**—Mark for silver goods (1864), 491.
- Robinson & Co.**, Northampton, VIII.
- Robinson & Co.**, Shrewsbury, VIII.
- Robinson, Luke**, 49.
- Robinson, Mr. Sydney Jessop**, 59.
- Robinson, Robt.**, 59.
- Roche, John**—Advertisement of gilt, silvered and plated buttons (1747), 17.
- Rocker of Rue de Sevres**, 172 *note*.
- Rock, Henry**—Mark for silver goods (1798), 480.
- Rockingham China**—Designs copied from Old Sheffield Plate mounts, 188.
- Rockwell, E. & S. S.**, New York—Customers of Watson & Bradbury (1822-4), 157.
- Rococo Designs**, Period of, 186.
- "**Rodgers & Sons.**"—Snuffers (ill.), 246.
- Rodgers, John, & Co.**—Mark for silver goods (1805), 481.
- Rodgers, Joseph, & Son**—Marks for silver goods (1812), 482; (1843), 487.
- Rodgers, Joseph, & Sons**—Marks.
Plated goods (1822), 434, 450.
Plated goods factored by Jos. Rodgers & Sons, 434.
Silver goods (1858), 490.
- Rodgers, Mr. John**, of Sheffield, VII.
- Rodgers, T.**—Mark for silver goods (1790), 478; (1802), 481.
- Roebuck, C.**—Mark for silver goods (1786), 477.
- Rogers, J.**—Mark (1819), 449.
- Rogers, M.**—Mark for silver goods (1776), 474.
- Rolle, Lord**, 254.
- Rolling.**
Durability secured by, 53.
Similar results with close plated and fused plated metal, 9 *note*.
- Rolling Metal for the Trade.**
Hancock, Joseph, separate business undertaken by, 15, 40, 109.
Horse power applied, 40.
- Rollinson, Dollif.**
Mark for silver goods, (1790), 478.
Repairs to silver and plated measures, 346 *note*.
- Rooke, B., & Son.**
Articles made by (ill.), 357, 358.
Mark for silver goods (1818), 483.
- Rosenhauer, Adolph Fred, & Co.**, Hamburg—Customers of Watson & Bradbury (1804), 159.
- Rosenstrauch**, Austrian or German maker, 161.
Mark, 172.
- Ross, Mr. F.**, Winchester, VII.
- Roth, Robt.**—Dublin dealer supplied by Watson & Bradbury (1803-7), 154.
- Rotherham, J.**—Mark for silver goods (1792), 478.
- Round, J., & Son**—Mark for silver goods (1867), 492.
- Round, John, & Sons**, 36.
- Rouse, Joshua**, of Kingstown, Jamaica—Customer of Watson & Bradbury (1796-1812), 158.
- Rowbotham, John.**
Birks, association with, 455 *note*.
Marks.
Old silver cutlery (1776), 455.
Plated goods, no marks used (1781), 443.
Silver goods (1776), 474; (1793), 479.
Registration at Goldsmiths' Hall, London, 38, 463.
- Rowbotham, John, & Co.**
Associates, 433.
Marks.
Plated goods.
Before 1773, 441.
1774, no marks used, 442.
Silver goods, 433 *note*.
1774, 473.
- Rowlings, B.**—Mark for silver goods (1823), 484.
- Royal Dublin Society**—Premium offered for manufacture of Plated Goods by Rollers in Ireland, (1783), 148.
- Royal Hotel, Cheltenham**—Old Sheffield Plate in use, 56.
- Royle, T.**—Mark for silver goods (1851), 488.
- Rubbing in Silver Shields**, *see* Shields.
- Rundle (or Rundell), and Bridges**—Reproductions of the Warwick Vase, 380.
- Runge, Hulsenebeck & Co.**, Hamburg—Customers of Watson & Bradbury (1804), 159.
- Ruoby, Chemist**, 142.
- Russia**—Goods made in, 162 (ill.), 162, 163.
Marks, 162, 171, 172.
- Ryland, W., & Son**—Marks (1807), 446.
- Ryland, William**—No marks used (before 1773), 441; (1774), 442; (1777), 442; (1781) 443.

S

- Sackville, Countess**, VII.
- Sacred Edifices**, Articles for, 274 (ill.), 275.
see also Communion Plate.
- St. Paul's Church, Sheffield**—Communion Flagon, 37 *note*.
- St. Peter, Abbey Church of, Gloucester**—Candlestick of "Pricket type," 214.
- Salad Bowl** in Britannia Metal (ill.), 499.
- Sale Room Values** of Old Sheffield Plate, 182-4.
Conditions affecting, 182.
Particulars from sale room records, 183.
- Salmon, Robert**—Candlestick patent, 247.
- Salt Cellars.**
Illustrated catalogues, designs from (1765-85), 398.
(1804), 415; (1848), 423.
Illustrations of various designs, 310-3.
Number of patterns, prices, etc., 309.
Pierced specimens, advance in price, 184.
Sheffield-made silver, 200, 309 (ill.), 200, 280, 466.
- Salt**—Mark, 452.

- Salvers or Waiters and Trays**, 316.
Austria, tray probably made in, 161 (ill.), 161.
Borders and Mounts.
Back to back method of strengthening mounts, 76-8 (ill.), 76, 77, 83.
Three methods of treatment (ill.), 83.
Boulsover, T., salver presented by, to his daughter, 25, 316 (ill.), 25.
Flat chased salvers and trays, value of, 73.
French make (ill.), 166.
French plating, tray repaired by (ill.), 97.
Illustrations of various designs, 25, 72, 73, 76, 77, 86, 95, 99, 126, 135, 166, 316-26.
Irish style, salver chased in, 151 (ill.), 151.
Period of production, 185, 316.
Processes of manufacture.
Account by an old workman, 133-6.
Illustrations, 135, 136.
Russia, tray made in, 162 and ill.
Sale room values, 183.
Silver and Sheffield Plate Salvers (ill.), 201.
- Samovar**, Russian Samovar, 162 (ill.), 163.
- Sampel, William**—Silver Sauce Boat made by (ill.), 85.
- Sampson, I.**—Mark for silver goods (1795), 479.
- Sanders, Wm. Chris.**, Hamburg—Customer of Watson & Bradbury (1800), 159.
- Sandford, Mr. H. B.**, of Sheffield, VII.
- Sansom & Creswick**—Mark for silver goods (1856), 489.
- Sansom & Davenport**—Mark for silver goods (1853), 488.
- Sansom & Harwood**—Mark for silver goods (1833), 486.
- Sansom, T., & Sons**—Mark (1821), 450.
- Sansom, W.**—Mark for silver goods (1835), 486.
- Sanson, T.**—Mark for silver goods (1808), 482.
- Saracen's Head, Lincoln**—Old Sheffield Plate in use, 56.
- Sauce or Butter Boats and Sauce Tureens.**
Date of introduction of sauce boats, 329.
Illustrated designs from catalogues (about 1777), 403; (1835), 419.
Illustrations of various designs, 85, 204, 329, 332-4.
Sale room values, 183.
Sauce Tureen with hot water jacket, 204.
Silver boat (ill.), 85.
Varieties of design, prices, etc., 329.
- Saucepans** plated inside.
Hancock, Joseph, saucepans made by, 30 (ill.), 32.
Illustrated design from catalogue (about 1848), 423.
- Savory, A. B., & Sons**—Name found on Articles of Old Sheffield Plate (about 1830-45), 146 *note*.
- Saw-making**—Boulsover's Invention, 10.
- Saw-piercing**, 118 and ill.
- Sayles, Lewis Charles**—Assay Master (1833), 464.
- Sayles, Matthew**—Assay Master (1809), 464.
- Saynor, J. & S.**—Mark for silver goods (1792), 478.
- Scales Device**, 429.
- Scallop Shell or Butter Dish**—Solid silver hard soldered edge (ill.), 92.
- Schultz, Ferdinand H. L.**, Hamburg—Customer of Watson & Bradbury (1797-1804), 159.
- Sconces** for Candlesticks (ill.), 236, 390.
- Scot, W.**—Marks (1807), 446, 451 *note*.
- Scotland**, Old Sheffield Plate in, 154-6.
Extent of trade with Sheffield makers, 154.
Local establishment, extent of, 154, 155.
- Scott, Mr. T. A.**, of Sheffield, VII.
- "Scrap,"** 67.
- Sears, Mr. W. T.**, Normanhurst, Northampton, VII.
- Second Course Dishes and Warmers** (ill.), 287, 288.
- Sephton, Henry**, Workman employed by Old Roberts, 31.
- Settle, J. & T., Gunn & Co.**—Mark for silver goods (1825), 485.
- Settle, John and Thomas** (Jno. and Thos., Thos. and John, J. & T., T. & J.)
Articles made by (ill.), 201, 313, 328, 353, 366, 385.
Marks for silver goods (1815), 470, 483.
Place among successors of John Winter, 434.
- Settle, John, & W. Hatfield**—Mark for silver goods (1802), 481.
- Settle, Thomas.**
Mark for silver goods (1781) 475.
Partnerships, 41, 42.
- Settle, Thos. & John**, *see* Settle, John and Thomas.
- Settle, Thomas, & Co.**—Marks.
Cutlery (1787), 459.
Plated goods—No separate mark, 460.
Silver goods (1780), 42, 475.
- Seynor, J.**—Mark for silver goods (1785), 476.
- Shakespeare, Johnson & Co.**, Birmingham—Glass supplied to M. Fenton & Co. and Watson & Bradbury, 68.
- Sharp, Mr. Andrew**, on supposed Edinburgh manufacture of Sheffield Plate, 155.
- Sharrow, J., & Co.**—Mark for silver goods (1793), 479.
- Shaving Lamp** (ill.), 391.
- Shaving Pot** (ill.), 204.
- Shaw, Rev. F. L.**, Vicar of Eyam, VII.
- Shaw, T.**—Mark for silver goods (1780), 475.
- Sheffield.**
Amount of Old Sheffield Plate to be found in, 1.
Infirmity—Old Sheffield Plate, 2.
Antiquity, 2.
Assay Office, *see* that title.
Charity founded by Mary Parsons for members of silver and plate trade, 2.
Climate, 51.
Population (1615-1911), 2.
Spelling of name, variations in, 461.
View of (c. 1745), frontispiece.
- Shemeld, J., & Co.**—Mark for silver goods (1777), 474.
- Shemeld, Parkin & Co.**—Mark for silver goods (1781), 475.
- Shephard, J.**—Mark (1817), 449.
- Sheraton, Thomas**—Influence on design, combined articles possibly due to Sheraton's influence, 368.
- Sherburn, Dr.**—Capital supplied to Tudor & Leader, 34.
- Shields** for engraving Crests, Monograms, etc.
Rubbing in silver shields.
Colour, difference between pure silver of shield and standard silver of surface of article, 94.
Competence of workman, test of, 94.
Description of process, 93-4, 134.

- Shields**, Rubbing in—*Continued*.
 French ware, silver shields not found in, 160.
 Illustrations, 95, 97.
 Inventor, question as to, 93.
 Labour saved, 91.
 Quality of pieces bearing rubbed in shields, 93, 95.
 Similarity of process to Wilks & Moteram process of plating wire, 81.
 Soldering in extra heavily plated shields.
 Description of process, 89.
 Illustrations, 90, 91.
 Illustrated design from catalogue (about 1795)—First illustration showing separately soldered in shields, 412.
 Prices—Illustration from old catalogue, 90.
- Ship in full sail Device**, 37, 430.
- Shoe Buckles**, *see* Buckles.
- Shore, J., & Co.**—Mark for silver goods (1799), 480.
- Shrapnel, Henry Needham Scrope**—Patent for improvements in Snuffers, 247.
- Shrewsbury, Earl of**, Gaoler of Mary Queen of Scots, 2.
- Silcock, Benjamin Blonk**, 9 *note*.
- Silk, R.**—Mark (1809), 447.
- Silkirk, W.**—Mark (1807), 446.
- Silver, Antique Silver.**
 Method of dealing in—Objections to custom of selling by weight, 181-2.
 Sheffield-made silver articles, 190, 200, 202, 461, 462, 466, (ill.) 190, 200-2, 280, 454, 466.
 Detachable parts from plated articles, 463. (ill.), 462.
 Value of hall marks in fixing date and maker of piece, 463.
 Duplication in plate, 200, 462, (ill.) 200-1.
 Dates and makers of plated goods ascertainable by comparison with silver pieces, 200.
 Marks, *see* title Assay Office, Sheffield.
 for particular articles, *see* their names.
- Silver Shields**, Rubbing in, *see* Shields—Rubbing in Silver Shields.
- Silver used in Plating.**
 Early ordinances fixing quality of silver, 4.
 Proportion used (gauge of plated metal), 78.
 Bright cut deep engraving, proportion needed for, 78, 86.
 Duty imposed on silver in 1784, effect of, 57.
 Foreign competition, possible effects of, 79.
 French ware, 160.
 Marks indicating, 78-9—France, 170.
 Standard silver used—Proportions, 11, 178, 453 *note*.
 Renovations, use for, 179.
- Silversmiths.**
 Efforts to discourage plating, 56.
 France, 168-9, 169 *note*.
 Factories—Size as compared with Old Sheffield Plate factories (1775), 66.
 First Association of Sheffield Silversmiths, members, objects, rules, etc., 51.
 Lists of marks, 472-493.
 London silversmiths, *see* title London.
 Pitchers or jugs, neglect of, 305.
 Stock-in-trade required in 1775, 66.
- Simmonds, H. T.**, Monmouth, VIII.
- Simmons, I.**—Mark for silver goods (1839), 487.
- Simpson, James**—Patent for Steel Snuffer, 247.
- Sissons, Mr. Walter**, VII., 44, 59.
- Sissons, W. & G.**—Successors of Roberts & Cadman, 59.
 Commercial descent, 44.
 Dies, preservation of—Explanation, 59-60 and 60 *note*.
 Marks.
 Plated goods, 430.
 Silver goods (1858), 490.
- Sissons, William**, 44.
- Sitwell, Francis**, 461.
- Sketchley.**
 Directory of 1774, extracts from, etc., 19, 196, 458.
 Lists of articles made in Old Sheffield Plate, 22 *note*, 231, 329.
- Skidmore, W.**—Mark for silver goods (1861), 491.
- Slack Bros.**—Mark for silver goods (1862), 491.
- Slater, J., & Son**—Mark for silver goods (1867), 492.
- Slater, Son & Horton**—Mark for silver goods (1859), 490.
- Small Articles** manufactured from Fused Plate—Persistence of industry, locality, etc., 147.
- Small, Thomas**—Mark (1812), 436, 448.
- Smallwood, J.**—Mark (1823), 450.
- Smallwood, T.**, Sheffield, VIII.
- Smart, James**, Birmingham—Glass supplied to M. Fenton & Co. and Watson & Bradbury, 68.
- Smee, Dr.**—Discovery of electro plating process, 47, 140.
- Smelle, E.**—Mark for silver goods (1799), 480.
- Smiles, Samuel**, 47, 49.
- Smith**—Partner of James Vickers in Britannia Metal business, 495.
- Smith & Co.**—Mark (1784), 444.
- Smith, B.**, London.
 Breakfast dish, upper part (ill.), 432.
 Mark, 433 *and note*.
- Smith, Daniel, and Robert Sharp**, of London—Over-marking, etc., 471.
- Smith, Evan**, 44.
- Smith, H.**, New York—Customer of Watson & Bradbury (1824), 157.
- Smith, I.**—Mark (1821), 450.
- Smith, J.**—Mark for silver goods (1775), 473.
- Smith, J., & Son**—Marks.
 Cutlery (1829), 460.
 Plated goods (1828), 450.
 Silver goods (1829), 485.
- Smith, J., & Sons (?)**—Mark on German silver chalice (about 1860), 440.
- Smith, Joachim**—Patent for raising candle automatically, 245.
- Smith, Josephus**—Maker of tankards, cups, etc., 346, 438.
 Excellence of work, 438.
 Marks.
 Plated goods (1836), 438, 451.
 Silver goods (1846), 488.
- Smith, Knowles, Creswick & Co.**—Mark for silver goods (1793), 479.
- Smith, R., & Son**, Scarborough, VIII.
- Smith, F. S.**, Bristol, VIII.
- Smith, Nathaniel.**
 Mark (before 1773), 441.
 Partnerships, 41, 42.
 Tankards, cups, etc., made by, 346.

- Smith, Nathaniel, & Co.** (afterwards Smith, Tate, Nicholson & Houlst and Smith, Tate, Houlst & Tate.
Articles made by (ill.), 158, 208, 228, 251, 255, 257, 272, 273, 284, 299, 303, 312, 313, 314, 322, 327, 332, 336, 345, 349, 356, 370, 372, 377, 384, 391.
Marks.
Cutlery (1787), 459.
Plated goods (1784), 431, 444.
Silver goods (1780), 475.
- Smith, Sissons & Co.**, 44.
Mark (1848), 451.
- Smith, Tate, Houlst & Tate**, 431.
- Smith, Tate, Nicholson & Houlst**—Marks.
Plated goods (1810), 431, 447.
Silver goods (1810), 482.
- Smith, W.**—Mark (1812), 448.
- Smith, W.**—Mark for silver goods (1775), 473.
- Snuff Boxes**, 19, 184 (ill.), 20, 21.
Britannia Metal (ill.), 498.
Manufacture removed to Birmingham, 198.
- Snuffer Trays.**
Illustrations of various designs, 199, 326-8, 421.
Sale room values, 183.
Variety of designs, uses, etc., 326.
- Snuffers** (ill.), 199.
Eccentric close-plated steel snuffers.
Casley, H. C. on, 244-5.
Illustration, 244, 246.
Fused plated (ill.), 246.
List of patents in connection with snuffers and candlesticks, 245, 247.
Sale room values, 183.
- Soho Plate Co.**, 50.
- Soldering.**
Excellence of (about 1789), 92.
Gas, introduction of—Advertisement by Green & Pickslay, 122.
Hard solder, 125.
Process with gas, 122-5 (ill.), 123.
Shields, soldering in, '89-91, 412.
Soft soldering, 122-5.
Soldering iron used in filling silver mounts (ill.), 82—others, (ill.) 122.
- Sorley, Bailie, the late**, of Glasgow, VII.
- Sorley, R. & W.**, Glasgow, VIII.
- Soup Ladle** (ill.), 336.
- Soup Plates**—Sale room values, 183.
- Soup Tureens.**
French specimens, 170, (ill.), 164.
Illustrations of various designs, 330-1, 389.
Number, variety of designs, etc., 329.
Turtle, tureen in form of (ill.), 389.
- Soy Frames**, *see* Cruet Frames and Soy Frames.
- Spain**, Roberts & Cadman's trade with, 58.
- Spiers, Mr. W. L.**, of Sir John Soane's Museum, VII.
- Spink & Son**, London, VIII.
- Spinning.**
Date of introduction, 116.
French and English methods, 116.
Process, 116-8, (ill.), 117.
- Spiridion, Mr. Joseph**, of Cardiff, VII., 162.
- Spirit Bottle** (ill.), 253.
- Spirit Kettle and Stand** for use when travelling—
French make (ill.), 169.
- Spooner, J.**—Mark for silver goods (1786), 477.
- Spoons and Forks**, *see* Forks and Spoons.
- Sporle, E., & Co.**—Mark for silver goods (1793), 479.
- Sporle, Robert, & Co.**—Mark for silver goods (1792), 478.
- Spread Eagle, Lincoln**—Old Sheffield Plate in use, 56.
- Spur, P., & Son**—Mark for silver goods (1788), 477.
- Squat Vase Device**, 2, 34.
- Stacey, E.**—Marks for Britannia Metal goods (1837), 497.
- Stacey, Henry, & Horton**—Mark for silver goods (1856), 489.
- Stafford & Newton**—Mark for silver goods (1787), 477.
- Staffordshire Ware** mounted by the Old Sheffield Platers, 338 (ill.), 339-40.
- Stamp Shop**, 103-4 (ill.), 104.
- Standard Silver**, Proportions, etc., 11, 178, 179, 453
note.
- Stands for Teapots**, 355.
Period of production, 185.
- Staniforth, J.**—Mark for silver goods (1804), 481.
- Staniforth, J., & Co.**—Mark for silver goods (1783), 476.
- Staniforth, Parkin & Co.**—Marks.
Cutlery (1787), 459.
Plated goods (1784), 444.
- "**Steak Dish**," 283 (ill.), 288.
- Steel, Mr. Henry**, of Sheffield, VII.
- "**Steeling**," 132.
- "**Sterling**," use as Mark, 453-4.
- Stevens, John Lee**—Candlestick patents, 247.
- Stokes, G.**—Mark for silver goods (1833), 486.
- Stollenwerk & Bros.**, New York—Customers of Watson & Bradbury (1815-1818), 157.
- Stone and Jasper Ware** with Mounts, 338 (ill.), 339-40.
- Storr, Paul**—Silver articles with Bases, etc., of Old Sheffield Plate, 433.
- Stot, B.**—Mark (1811), 448.
- Stout & Platts**, New York—Customers of Watson & Bradbury (1817-8), 157.
- Strainers** (ill.), 392, 393, 499.
Illustrated design from catalogue (about 1848), 423
- Stratford, Mr. W. O.**, of Sheffield, VII.
- Stratford, W. & H.**—Mark for silver goods (1855), 489.
- Stripping Place**, 67 and ill.
- Sub-division of Labour** not in vogue in manufacture of Old Sheffield Plate 60 or 70 years ago, 133.
- "**Sud Pot**," 132.
- Sugar Basins.**
Britannia Metal (ill.), 498.
Covered basin, Paris make (ill.), 169.
Illustrated designs from catalogues (about 1784), 408; (1798), 413.
Pot à sucre avec 12 Cuilliers autour (ill.), 57.
Pierced specimens, advance in price, 184.
Sheffield-made silver (ill.), 466.
Uses in earlier period of production, period when first manufactured as part of "services," 341 (ill.), 341-3.

- Sugar Castors**, 341 (ill.), 343.
Sugar Crusher (ill.), 389.
Sugar Tongs, 335 (ill.), 336.
Sullivan, Henry, Dublin—Advertisement (1768), 149.
Sun Device, 49, 430.
Supper Services, 344, (ill.), 345.
Surtees, Col. H. C., VII.
Surviving Methods, 98-132.
for details, see names of processes.
Sutcliffe, Sporle & Co., or R. Sutcliffe & A. Sporle, R. Sutcliffe & Co., Robert Sutcliffe.
 Marks,
 Cutlery (1787), 459.
 Old silver cutlery (1781), 455
 Plated goods (1786), 445.
 Silver goods (1787), 475.
Swages and Swaging, 114, 115.
 Number, variation in shape and size of swages,
 115 (ill.), 113.
 Process of swaging, 113-5 (ill.), 114, 115.
 Use of swages, 113.
Swan Hotel, Bedford—Old Sheffield Plate in use, 56.
Sweepings, Value of, 14.
Sweet Dishes.
 "Comfores," 198.
 Illustration, 213.
Swift, J., & Co.—Mark for silver goods (1784), 476.
Sykes & Co.
 Marks,
 Cutlery (1787), 459.
 Old Silver Cutlery (1781), 455.
 Plated goods (1784), 444.
 Silver-handled knife and fork (ill.), 456.
Sykes, D.—Mark for silver goods (1792), 478.
Sykes, John, & Co.—Marks for silver goods (1792), 478,
 (1808), 482.
Sykes, John & Dennis.
 Marks—None used (1781), 443.
 Pierced fish slice (ill.), 392.
 Silver handled cutlery, 40.
Sykes, J. D., & Co.—Mark for silver goods (1781), 475.

T

- Table Bell** (ill.), 389.
Tankards, Beakers, Cups, Bowls and Measures, 151, 346,
 Bodies of tankards with covers, method of
 raising in early period, 62.
 Demand for tankards and measures among Inn
 Proprietors—Pewter supplanted by Old Shef-
 field Plate, 54.
 Dies—Prices, 61.
 Double sheets of metal, tankards made from
 by J. Hancock, alleged, 77.
 Illustrations of various designs, 150, 346, 347,
 348-51, 425.
 Marks on tankards, slits beneath handles, etc.,
 347.
 Oldham, Thomas, of Nottingham, tankards made
 by, 146, 147.
Taper Candlesticks and Taper Holders, 249-5 (ill.), 250.
 Sale room values of taper holders, 183.
Taps of Tea Urns (ill.), 144.
 Cast metal taps on urns made before discovery
 of German silver and electro-plating, 144.
 Electro-plated German silver (ill.), 364.

- Taylor & Brown**, Baltimore—Purchasers of Old Shef-
 field Plate, 156.
Taylor & Hinsdale, New York—Customers of Watson
 & Bradbury (1816-24), 157.
Taylor, J.—Mark for silver goods (1822), 484.
Taylor, Mr. J., Northfield, Birmingham, VII.
Tea Caddies and Canisters, 352 (ill.), 85, 187, 352, 353.
 Britannia metal (ill.), 498.
 Design and size, 352.
 "Faked" piece (ill.), 177.
 Locks and keys, 352.
Tea Kitchens—Dies, Prices, 62.
Tea Machines, 344 (ill.), 367.
 Illustrated design (2 patterns), from catalogue
 (about 1808), 416.
Tea Services (ill.), 358.
 Illustrated design from catalogue (about 1830), 419.
 Sale room values, 183.
 Style in demand (1850-87), 186.
Tea Shells (probably Caddy Spoons), 149.
Tea Urns, 158-9.
 Fused copper plated bodies, urns made with, long
 after introduction of electro-plating, 144.
 Heating arrangements 359 (ill.) 361.
 Illustrated design from catalogue (about 1782)
 showing Flaxman's influence, 407.
 Illustrations of various designs, 88, 159, 160,
 360-6.
 London copper and tinsmiths, urns made by,
 during the Old Sheffield Plate period and
 subsequently electro-plated, 180-1 (ill.), 181.
 Period of production, size, etc., 359.
 Sale room values, 183.
 Warwick Vase, tea urn in form of, 378 (ill.), 379.
Teapots.
 Ball feet, introduction of, followed by disap-
 pearance of stands, 185.
 Beauty of design *versus* utility, 352.
 Britannia metal (ill.), 499.
 Combination interchangeable coffee pot, stand and
 lamp, and teapot (ill.), 259.
 Handles and knobs, 354.
 Illustrations of various designs, 88, 158, 354,
 355-7.
 Method of making in 1775, 63.
 Number in existence, period of production, etc.,
 354.
 Paris make (ill.), 168.
 "Queen Anne" design, 353.
 Renovation, difficulties of, 179.
 Sale room values, 183.
 Soldered-on band for engraving (ill.), 91.
 Spout (ill.), 144.
 Stands, *see* that title.
Tearoe, Mr., of Sanderstead, VII.
Teasdell, G.—Mark for silver goods (1859), 490.
Teaspoons, 335 (ill.), 336.
Telescope, small Telescope (ill.), 390.
Temper—Composition, etc., 500.
Thomas & Co., New Bond Street—Name marked on
 Old Sheffield Plate, 429.
Thomas & Co., London.
 Bread tray (ill.), 211.
 Mark, 433.
Thomas & Smith, New York—Customers of Watson &
 Bradbury (1823-4), 157.

- Thomas, F. B., & Co.**, London, VIII.
- Thomas, S.**—Mark (1813), 448.
- Thomason, Sir Edward.**
Close plating, 7.
Telescopic toasting fork, inventions, 387 and ill.
Warwick Vase, reproduction of, in bronze, 380.
Wine-wagon, invention of, 254.
- Thomasons of Birmingham, Thomason & Dowler**—
Marks, 435 (1807), 446.
- Thompson & Barber**—Marks for silver goods (1809),
482.
- Thompson & Brown**—Mark for silver goods (1844), 488.
- Thompson, George Alexander**—Patent for spring
snuffers, 245.
- Thompson, J.**—Marks for silver goods (1868), 493.
- Thorpe, Glossop & Middleton**—Mark for silver goods
(1834), 486.
- Tibbitts, J.**—Mark for silver goods (1778), 474.
- Timm, F. E.**—Mark for silver goods (1857), 489.
- Tinder Boxes**, 374, 376 (ill.), 374.
- Tinker, S.**—Mark for silver goods (1824), 484.
- Tinning**—Methods, etc., 129.
- Toast Racks or Toast Trays**, 368 (ill.), 199, 369.
Date of introduction, 368.
Folding toast racks—S. Roberts's, junr., patent,
43.
Toast rack and egg cup combinations, 368 (ill.),
370.
- Toasting Forks**, Telescopic—Sir E. Thomason's inven-
tion, 387 and ill.
- Tobacco and Cigar boxes**, 374 (ill.), 375, 376.
- Tompkin, Mr.**, 156.
- Tonks & Co.**—Mark (1824), 450.
- Tonks, Samuel**—Mark (1807), 446.
- Tonks, William**—No Marks used (1774), 442.
- Tools**—Early trade prices, 61.
for particular tools, see their names.
- Toothpick Holder** made in France (ill.), 163.
- Torrey, Dr. J., Junr.**, of Blundellsands, VII.
- Towndrow Bros.**—Mark for silver goods (1864), 491.
- Townsend, Wm.**—Silver Dish Ring (ill.), 278.
- Trade in Old Sheffield Plate** during its Period of
Production.
Continental and colonial trade, *see* titles Conti-
nental Countries and Colonies.
Extent of, comparison with trade in solid silver
articles, 396.
Fluctuations during lifetime of T. Nicholson,
45-6.
Value of goods sent to London in one week in 1760.
—Horace Walpole's statement, 2.
see also title Demand.
- Travis, Josiah**—Antique silver watch, 461 and ill.
- Travis, Mr. G. R.**, of Sheffield, VI.
- Travis, Nathaniel**, 461 *note*.
Mark for silver goods (1789), 477.
- Trays**, *see* title Salvers or Waiters and Trays.
- Trenchers**, *see* title Dishes or Trenchers.
- Triangle with two Curls or Ears Device**, 439.
- Tricket, Haslehurst, Whiteley & Pryor**—Mark for
cutlery (1787), 459.
- Tricket, R., & Co.**—Marks for silver goods (1786), 477.
- Trickett, or Tricket, Robert.**
Marks.
Old silver cutlery (1773), 455.
Silver goods (1773), 472.
Silver handled knife and fork (ill.), 456.
- Trowels** for Housekeeping purposes and Presentation
(ill.), 388.
- Troy Weight Device**, 438.
- Trumpet Device**, 437-8.
- Trumpet with Banner Device**, 496.
- Trusler, John**—Patent for spring snuffer, 245.
- Tucker, Fenton & Co.** (W. Tucker, James Fenton &
Co.)
Articles made by (ill.), 249, 252, 263, 284, 297,
318, 332, 388.
Mark for silver goods (1796), 479.
- Tucker, W., J. Fenton, E. G. Machon**—Mark for silver
goods (1810), 482.
- Tucker, William**, 37 *note*.
- Tuek's Method** of "Bright plating," 140.
- Tudor, Henry**, 34-6, 338 *note*.
Portrait, 35.
Registration at Goldsmiths' Hall, London, 35,
38, 463.
- Tudor & Leader** (Henry Tudor & Thomas Leader),
31, 34-6, 40.
Articles made by, illustrations, etc., 21, 33,
189, 205, 221, 224, 248, 255, 260, 266, 280,
308, 309, 310, 314, 316, 317, 326, 342, 354, 391.
Factory, establishment of, 34.
Marks.
Plated goods.
Before 1773, 35, 36, 397, 441.
None used (1774), 442; (1781), 443.
Silver goods (1773), 472.
Members of first Association of Sheffield Silver-
smiths, 51.
- Tudor, Henry, & Samuel Nicholson**—Mark for silver
goods (1797), 36, 480.
- Tudor, Jno.**—Dublin dealer supplied by Watson &
Bradbury (1795-1801), 154.
- Tudor, Leader & Nicholson, or Tudor & Co.**, 36, 446 *note*.
Mark (1784), 36, 444.
- Tuffin & Ciovsno**, Amsterdam—Customers of Watson
& Bradbury (1802-4), 159.
- Tugot, Marie Joseph, and Jacques Daumy**, firm of,
168-9.
Soup tureen by, 170.
- Tumbler Holder** (ill.), 255.
- Turley, S.**—Mark (1816), 449.
- Turner**—Mounted Ware, 338 (ill.), 340.
- Turner, Mr. S. W.**, VII.
- Turner, T., & Co.**—Mark for silver goods (1865), 491.
- Turner, Thomas**—Mark for silver goods (1853), 488.
- Turton, J.**—Marks (1820), 449.
- Twycross, John**—Dublin dealer supplied by Watson
& Bradbury (1808-12), 154.
- Tyas, Thomas, Junr.**—Registration at Goldsmiths'
Hall, 38, 463.
- Tyndall, J.**—Mark (1813), 448.

U

- Underdown, Wilkinson & Co.**—Mark for silver goods (1826), 485.
Unite, G.—Mark for silver goods (1861), 491.
United States, *see* America.
Urton, W.—Mark for silver goods (1788), 477.
Usher, Mr. J. W., of Lincoln, VII.

V

- Vander & Hedges**, London, VIII.
Vases, 72, 340.
Vaughan, T.—Mark for silver goods (1818), 483.
Vegetable Dishes with Covers, 284 (ill.), 288.
 Sale room values, 183.
Venison Dish Wedge (ill.), 392.
Venison Dishes and Covers (ill.), 266.
 Sale room values, 183.
Vessel for mixing Drinks (ill.), 393.
Vickers, Mr. D., of Sheffield, VII.
Vickers, James—Britannia Metalsmith, 494.
 Articles made by (ill.), 498.
 Dixon's, Mr. Charles, notes, 495.
 Mark (1787), 497.
Vickers, John—Britannia Metalsmith, 495.
 Mark (1817), 497.
 Teapot made by (ill.), 499.
Victory Inkstand, 297 (ill.), 298.
Vinaigrettes, 198.
Vincent, Edgar, Yeovil, VIII.
Vokes, E. J., Bath, VIII.

W

- "**W.R., 1830**"—Snuffers (ill.), 246.
Waiters, *see* title *Salvers or Waiters and Trays*.
Waldeck, Mr., of London, VII.
Walker & Co.—Re-plating Advertisement (1852), 173 *note*.
Walker & Hall—Marks for silver goods (1862), 491 ; (1868), 493.
Walker Bros., Hamburg—Customers of Watson & Bradbury (1800-5), 159.
Walker, Francis Prime, Junr.—Candle and candlestick patents, 247.
Walker, Knowles & Co., 133.
 Marks.
 Plated goods (1840), 440, 451.
 Silver goods (1840), 487.
Walker, Mr. W., of Sheffield, VII.
Walker, S., & Co.—Mark for silver goods (1836), 487.
Walker, Thomas—Patent for self-acting extinguisher, 247.
Wall Bracket Sconce (ill.), 236.
Walpole, Horace—Letter mentioning Sheffield and purchase of Sheffield Plate, 2.

- Warburton, S., & Co.**—Marks for silver goods (1775), 473.
Ward, Frederick Oldfield—Refrigerating caps patents, 247.
Ward, George—Mark for silver goods (1846), 488.
Ward, W. & S.—Mark for silver goods (1858), 490.
Wardell & Kempson—Mark for silver goods (1811), 482.
 " **Warmers** " for Entrée, etc., Dishes, 283-4 (ill.), 286, 287, 288, 289.
Warner, John, Cork—Advertisement (1786), 149.
Warren, H. E., of Sevenoaks, VIII.
Warren, Thos., New York—Customer of Watson & Bradbury (1805-7), 157.
Warris, T., & Son—Mark for silver goods (1796), 479.
Warris, Thomas.
 Partnerships, 41, 42.
 Silver-handled fork (ill.), 456.
Warry, Mr., 216.
Warwick Vase, 185 *note*.
 Articles in form of—
 Tea urn, 378 (ill.), 379.
 Wine coolers, 377 (ill.), 378.
 Original.
 Description, account of discovery and restoration, 380-1.
 Dimensions, 381.
 Reproductions in bronze and silver, 380.
 Steel engraving in catalogue, 397.
Warzawa—Mark, 172.
Wass, R.—Mark for silver goods (1810), 482.
Watch, Antique silver watch by Josiah Travis, 461 and ill.
Waterhouse & Co., retail firm of Dublin, 148.
Waterhouse & Co.—Mark (1807), 447.
Waterhouse, Hatfield & Co. (John Waterhouse, E. Hatfield & Co.),—Marks.
 Plated goods (1836), 451.
 Silver goods (1836), 487.
Waterhouse, George, 435.
Waterhouse, George, & Co.—Marks.
 Plated goods (1842), 451.
 Silver goods (1842), 487.
Waterhouse, I. & I., & Co., or Waterhouse, Hodgson & Co.
 Articles made by, illustrations, etc., 257, 289, 295, 328, 377, 378, 379, 386.
 Marks.
 Plated goods (1833), 379, 435, 451.
 Silver goods (1822), 484.
Waterhouse, Mr. S. S., 148.
Waterhouse, Revd. Robert, 37 *note*.
Waterhouse, Thomas, 435.
Watkinson, Hannah—Mark for silver goods (1792), 478.
Watkinson, Hannah and William Watson—Mark for silver goods (1793), 479.
Watkinson, J.—Mark for silver goods (1776), 474.
Watson & Bradbury (W. Watson & T. Bradbury), 37.
 American trade, 156-7.
 Apprenticeship deed executed by (1800), 53 (ill.), 54.

Watson & Bradbury—*Continued.*

- Articles made by, illustrations, etc., 55, 76, 155, 207, 211, 226, 227, 228, 229, 230, 235, 248, 251, 252, 256, 265, 270, 271, 274, 283, 284, 285, 286, 288, 299, 302, 303, 304, 305, 313, 314, 317, 318, 327, 330, 331, 332, 333, 351, 355, 356, 363, 364, 365, 369, 370, 371, 373, 382, 385, 389, 392, 417, 418.
List of articles manufactured (1788-1815), 196-7—Comments, 198.
Continental trade (1790-1815), 159.
Glass—List of manufacturers supplying glass to Watson & Bradbury, 67-8.
Irish trade—List of dealers in Dublin (1795-1813), 153-4.
Mark for silver goods (1826), 485.
Scottish trade (1795-1812), 154.
- Watson, Fenton & Bradbury** (Thomas Watson, James Fenton and Thomas Bradbury)—Marks.
Plated goods (1795), 430, 445.
Silver goods (1795), 479.
- Watson, John.**
Articles made by (ill.), 249, 256, 331.
Mark for silver goods (1795), 432, 479.
- Watson, John, Junr.**, 432.
Assay Master (1854), 432, 464.
- Watson, John & Son.**
Articles made by (ill.), 263.
Marks.
Plated goods (1830), 432, 450.
Silver goods (1822), 484.
- Watson, Mr. Arnold T.**, of Sheffield, VII.
Assay Master (1890), 464.
- Watson, Mr. Bernard W., M.A.**—Assay Master, VII., 463 *note*, 464.
- Watson, Pass & Co.** (late J. Watson).
Articles made by, illustrations, etc., 156, 324, 348, 358, 364.
Mark (1811), 432, 448.
- Watson, Sir Henry**, 59.
- Watson, T., & Co.**—Marks, 37.
- Watson, Thomas**, 37.
- Watson, W.**—Mark (1833), 438, 451.
- Watson, William**, 38 *note*.
- Watson, William**, nephew of Thomas Watson, 37.
- Watson, Wm., & Co.**—Mark for silver goods (1832), 486.
- Watson, William Henry**—Assay Master (1878), 464.
- Watt, James**, 47.
- "Wax Winders," 250 (ill.), 251.
- Wearing qualities** of Old Sheffield Plate, 180 and ill.
- Webster, Danby & Co.**—Mark for silver goods (1822), 484.
- Webster, Thomas**—Charges for dies and tools, 61.
- Wedgwood, Josiah.**
Boulton's work for, 50.
Influence on design, etc., 30, 185, 194.
Portrait, 193.
Pottery with mounts, 338.
- Weight, sale by**—Objections to custom in regard to Old Silver, 181-2.
- Wellington, Duke of**, Wine-wagon presented to, by George IV., 254.

West Indies, trade with, 157-8.

West, Mattw.—Dublin dealer supplied by Watson & Bradbury (1795-1813), 154.

West, Mr. L. A., of Dublin, VII., 152.
Notes on Irish dish rings, 276-7.

Westminster Abbey, Designs taken from, 30.

Westropp, Mr. Dudley, of the Irish National Museum, VI., 62, 92 *note*, 148, 150.
Irish glass, researches on question of, 69.
"Irish Rings," period of production of, 276.

Westwood, Mr. Arthur, of Harborne, Birmingham, VI.

Wheeler, Mr. Frank C., of London, VII.

Whip, J., & J. Rose—Mark for silver goods (1822), 484.

White & Johnstone—Mark for silver goods (1859), 490.

White Hart Hotel, Windsor—Old Sheffield Plate in use, 56.

White, Henderson & Co.—Mark for silver goods (1866), 492.

White Horse, Ipswich—Silver plate, 55.

White, J. (White & Allgood)—Mark (1811), 448.

White Metal, *see* Britannia Metal.

Whitelock, H., & Co.—Mark for silver goods (1792), 478.

Whitstone—Dublin dealer supplied by Watson & Bradbury (1805-10), 154.

Whittington—Glass production, 67, 68, 69.

Wiggin, Henry, & Co., 138.

Wild, W., & Co.—Mark for silver goods (1784), 476.

Wilkes, John—Patents for snuffers, 245 (ill.), 244.

Wilkinson & Roberts—Mark for silver goods (1831), 486.

Wilkinson, Henry, & Co.
Candlestick made by (ill.), 231.
Commercial genealogy, 434.
Marks.

Plated goods (1836), 434, 451, 460.
Silver goods (1831), 486; (1852), 488.

Wilkinson, J.—Mark for silver goods (1790), 478.

Wilkinson, Messrs. H. D., 173 *note*.

Wilkinson, Robt. Fredk., 59, 433.

Wilks—Invention of process of rubbing in silver shields, etc., 43, 93.

Wilks & Moteram—Process for plating wire, 81.

Willets, Thos., Junr., of New York—Customer of Watson & Bradbury (1807-10), 157.
Debit item in books of Watson & Bradbury, 156.

Williams, Robt.—Dublin dealer supplied by Watson & Bradbury (1799-1813), 154.

Williamson, Lewis—Dublin dealer supplied by Watson & Bradbury (1805-10), 154.

Willis, Abraham—Patents, 247.

Willmore, J., Birmingham.
Close plated steel snuffers made by (ill.), 244.
Marks, 435.

Willson, Mr. Walter, of Richmond, VII.

Willmore, Joseph—Marks (1807), 447.

Wilson—Mark 452.

Wilson & Sharp, Edinburgh, VIII.

- Wilson, Joseph**, 40.
Marks.
Plated goods.
1774—None used, 442.
1793, 42.
Silver goods (1773), 473.
- Wilson, Joseph, & Co.**—Mark for silver goods (1793), 42, 479.
- Wilson, Mr. Cecil**, of Sheffield, VII.
- Wilson, Mr. R. T.**, of Sheffield, VII.
- Wilson, Roger**, 433.
- "**Winchester Measure**," 346 *and note*, 347 (ill.), 346.
- Wine Coolers or Ice-pails.**
Illustrations of various designs, 169, 189, 378, 382-6.
Monteith (ill.), 189, 383.
Paris make, specimen of (ill.), 169.
Period of production, prices, etc., 377-8.
Sale room values, 183.
Warwick Vase, wine coolers in form of, 377-8 (ill.), 378.
- Wine Glass Holder or Fruit Dish** by Levrat, Paris (ill.), 163.
- Wine Glass or Tumbler Holder**, fire gilt (ill.), 72.
- Wine Labels** (ill.), 253.
Illustrated designs from catalogues (1770-90), 399.
- Wine, B.**, Dublin, VIII.
- Wine, L.**, Dublin, VIII.
- Wine Strainer** (ill.), 392.
Britannia Metal (ill.), 499.
Illustrated designs from catalogue about 1848, 423.
- Wine Wagon** (ill.), 257-8.
Thomason's, Sir E., invention, 254 *and notes*.
- Winston, H.**, Cardiff, VIII.
- Winter & Parsons, or Winter, Parsons & Co.**, 31, 38.
Members of first Association of Sheffield Silversmiths, 51.
- Winter, John.**
Candlestick-making business, 40.
Silver candlesticks, 189, 191.
Commercial posterity, 434.
Marks.
Plated goods (1765-73), 435.
Silver goods (1778), 474.
Partnerships, etc., 38, 40—Retirement, 42.
Registration at Goldsmiths' Hall, London, 38, 463.
- Winter, John & Co.**
Articles made by (ill.), 220, 221, 222, 223, 224, 233, 250, 394, 435.
Marks.
Plated goods (before 1773), 441.
Silver goods (1773), 473.
- Winter, Parsons & Hall**, Successors of John Winter, 434.
Candlestick trade, 219.
Marks—None used (1774), 442; (1781), 443.
Parsons, John, & Co., change to, 42.
- Wire, Plated Wire.**
Burnish used (ill.), 81.
Drawing wire, process of, 107 *and ill.*
Invention, 79.
Jug with top and lip protected with plated drawn wire mount (ill.), 86.
- Wire—Continued.**
Solid plated wire, process of making (1768), 79.
Strength given by use of, as compared with "self mounts," 79 (ill.), 80.
Wilks & Moteram, process invented by, 81.
Rubbing in the silver shield, similarity to, 81.
- Wire-work**—Interlaced patterns, period of production, 185.
- Withers, B.**—Mark for silver goods (1781), 475.
- Withers, Benjamin**, 433.
- Withers, Benjamin, & Co.**—No mark used (1781), 443.
- Withers, Joseph**, 433.
- Withers, Mr. G. N.**, of London, VII.
- Withers, William**, Leicester, VIII.
- Withey, Esther**—Glass Cutter, 69.
- Withey, John**, Sheffield—Glass supplied to M. Fenton & Co. and Watson & Bradbury, 67, 69.
- Wolf, Johann. Chris. Wilh.**, Hamburg—Customer of Watson & Bradbury (1809), 159.
- Wolstenholme, J.**—Mark for silver goods (1850), 488.
- Wolstenholme, Joseph**—Britannia Metalsmith.
Mark (1828), 497.
Salad bowl (ill.), 499.
- Women**, employment in Burnishing, 130, 134.
- Wood, George**, Nottingham, VIII.
- Woodhead, George**, 59.
- Wood's Hotel, Holborn, London**—Silver plate, 54.
- Woodward, W.**—Mark (1814), 449.
- Woolen, John**, 437 *note*.
- Woolrich, John Stephen**—Inventor of electro-plating machine, 140.
- Workmanship**, quality of, 52, 53.
Early makers, 51.
Electro-plating, introduction of—Effect on workmanship, 52.
Epergues, late Georgian épergues, 290.
Period of production, guide to, 186.
Silversmith, comparison of plater with, 52.
- Workmen.**
Candle light suppers, 40.
Character, 40, 41.
Demand for, 31, 40, 41.
Marks, 440.
Skill needed, 133.
Sources of supply, 31, 184.
Wages, 31.
Fluctuations almost unknown, 41.
- Workshops, List of**, with contents and values, 63-5.
- Worthington, T.**, Burton-on-Trent, VIII.
- Worton, S.**—Mark (1821), 450.
- Wostenholme, G.**—Mark for silver goods (1809), 482.
- Wostenholme, W. F.**—Mark for silver goods (1858), 490.
- Wrangham, W.**—Mark for silver goods (1817), 483.
- Wright, J.**—Mark for silver goods (1789), 477.
- Wright, J., & G. Fairbairn**—Marks.
Plated goods (1809), 438, 447.
Silver goods (1809), 482.
- Wyon**—Punches cut for Crowns used at Sheffield Assay Office, 465.

Y

Young, William—Lamp and candlestick patents, 247.

Young & Deakin—Mark for silver goods (1813), 483.

Young, C. F.—Mark for silver goods (1836), 487.

Young, Greaves & Hoyland (Young), 31, 38.

Date of foundation, 214 *note*.

Marks—None used (1781), 443.

Teapot made by (ill.), 355.

Young, Henry, New York—Customer of Watson & Bradbury (1819-23), 157.

Younge, J., & Co.

Articles made by (ill.), 267, 289, 304, 307, 311, 315, 342, 353, 363, 375.

Marks for silver goods (1779), 470, 474.

Younge, J., & Sons.

Articles made by (ill.), 204, 213.

Marks for silver goods (1788), 470, 477.

Younge, J. T., & Co.—Marks for silver goods (1797), 480.

Younge, S. & C., & Co.

Articles made by (ill.), 318, 330.

Marks

Plated goods (1813), 448.

Silver goods (1811), 470, 482.

INDEX TO MARKS

A

AB, 480, 493.
 ABBA, 458, 459.
 AB & Co., 491.
 ABFB, 492.
 AC, 485.
 AC & Co., 485.
 AC LEA, 447.
 AD, 480.
 AE Co., 441.
 AEW H GA IH EE, 452.
 AG & Co., 479, 481.
 A. GOODMAN & Co., 437, 445.
 AH, 483, 484, 485, 488.
 AHJH, 8, 447.
 AM, 171.
 A & O, 485.
 AS, 320, 475.
 A & S, 490.
 ALLGOOD, 448.
 ALLPORT, 448.
 ARGENT, 459.
 ASHFORTH & Co., 429.
 ASHLEY, 449.
 ASKEW MAKER NOTTINGHAM,
 450.

B

BB, 474, 475, 478, 491.
 B & C, 490, 491.
 BEST, 448, 449.
 B & F, 49, 441.
 BH, 482, 485.
 BH & H, 470, 483.
 BM, 484.
 BP, 481.
 B & P, 483, 501.
 BR, 483, 484.
 BS, 347, 433.
 BW, 475.
 BW & A, 487.
 BANISTER, 447.
 BELDON, 447.
 BELDON HOYLAND & Co., 445.
 BEST PLATE, 335, 452.
 BISHOP, 451.
 BOULTON, 444.
 "BOULTON'S PATENT
 FASTENER," 23.
 BRADSHAW, 450.
 BRITAIN WILKINSON &
 BROWNILL, 445.

C

CB, 171, 487, 501.
 C BALAINE, 171.
 C BALAINE A PARIS, 171.
 CB DOUBLÉ, 171.
 C & CO, 491.
 CFY, 487.
 C H & C, 481.
 C H J E, 492.
 CHS, 484.

CLP, 472.
 CLIL, 493.
 CM & P, 484.
 CN, 482.
 C NEEDHAM MAKER
 SHEFFIELD, 450.
 CP, 479, 485.
 CR, 477.
 CAUSER, 450.
 CHESTON, 447.
 CHILD, 450.
 CLARBOUR, 459.
 COLMORE PATENT, 445.
 COPE, 449.
 CORN & Co., 449.
 CRACKNALL, 448.

D

DADLEY'S PATENT, 23.
 DB & Co., 480.
 DC, 474.
 D & G HOLY & Co SHEFFIELD,
 433.
 DH, 473.
 DH & Co., 474.
 D HORTON, 447.
 DL, 480.
 DR, 478.
 DS, 451, 471.
 D & S, 462, 485.
 DSK & Co., 475.
 DSRS, 471.
 DAN HOLY PARKER & Co.,
 433, 445.
 DAN L. HOLY WILKINSON & Co.,
 433, 444.
 DAVIS, 449.
 DEAKIN SMITH & Co., 445.
 DENNIS SYKES, 478.
 DEVER, 452.
 DIXON, 497.
 DIXON & Co., 444.
 DIXON J., 451.
 DIXON & SON, 497.
 DOUBLÉ, 170, 171, 172.
 DOUBLÉ, AB, 161, 171.
 DOUBLÉ, AF, 171.
 DOUBLÉ CB, 171.
 DOUBLÉ DURAND, 172.
 DOUBLÉ JANTY, 171.
 DOUBLÉ LP, 172.
 DUNN, 447.
 DURAND A PARIS, 172.

E

EB, 482, 487.
 EG, 479.
 E GOODWIN, 445.
 EJM, 492.
 E M & Co., 490.
 EM JM, 492.
 ER, 478.

ERTR, 491.
 ES, 480.
 ES & Co., 479.
 E STACEY SUCCESSORS TO
 I VICKERS BRITANNIA
 PLACE SHEFFIELD, 497.
 EKHARDTS PATENT, 216.
 ELLERBY, 445.
 10E 10EM 20EM, 170.

F

F & A, 489.
 F BRs, 490.
 FET & Co., 489.
 FI, 171.
 FM, 484.
 F MADIN & Co., 445.
 F MOORE, 449.
 FW & D, 484.
 FABRE, 459.
 FOX PROCTOR PASSMORE &
 Co., 444.
 FREETH, 449.
 FROGGATT COLDWELL &
 LEAN, 445.

G

G, 452.
 GA, 447, 458, 484.
 GA & Co., 428, 472.
 GB, 476.
 GB & Br., 481.
 GBBS, 447.
 GB & Co., 475.
 GC, 477, 480.
 G & C, 488.
 GD, 440, 479, 483, 488.
 GE, 490.
 GE & Co., 479.
 GH, 450, 476, 480, 485, 486, 490.
 GHCH, 489.
 GH & Co., 491.
 GHF, 450.
 GPS, 448.
 GR, 451.
 GR IV (1824), 347.
 GR BRADBURY, 460.
 GR DIXON'S IMPERIAL, 347, 451.
 GS, 486.
 GT, 490.
 GU, 491.
 GW, 482, 488.
 GW & C, 482.
 GAINSFORD, 47, 437, 447.
 G AN ARGENT, 171.
 GANDAIS, 172.
 GARNETT, 445.
 GARNITURE ARGENT, 170, 172.
 GENEVA, 458.
 GIBBS, 447.
 GILBERT, 448.
 GILBERT LONDON, 452.
 GREEN, 446.

H

H, 450.
 HA, 451, 487, 488, 489.
 HB, 480.
 H & B, 485.
 HB & H, 470, 483, 488.
 HC, 481.
 HD, 487.
 HDW & CO, 486.
 HE & Co., 486.
 HF, 449.
 H & F, 489.
 HG & Co., 475.
 HH, 450, 488.
 H & H, 486.
 HH & JEB, 493.
 HR, 480.
 H & S, 451.
 HT, 36, 441.
 H & T, 475.
 HT & Co., 33, 35, 36, 441, 480.
 HTTL, 472.
 HW, 478.
 HW & Co., 478, 479, 486.
 HALL, 449.
 HANSON, 448.
 HARRISON, 447.
 HARWOOD, 449.
 HILL, 446.
 HILL & Co., 446.
 HINKS, 448.
 HIPKISS, 447.
 HOBDAV, 450.
 HOLDSWORTH, 497.
 HOLLAND & Co., 444.
 HOLY S & Co., SHEFFIELD, 450.
 HORTON, 447.
 HOWARD, 447.
 HUMBLE, 459.
 HUTTON, 439, 446, 451.
 HUTTON, SHEFFIELD, 451.

I

IB, 171, 436, 440, 476, 477, 484, 489.
 IB & Co., 484.
 IC, 473, 474, 475, 476, 478, 483.
 ID, 474, 475, 477, 481.
 ID & Co., 481.
 I DRABBLE & Co., 433, 446.
 IE, 483.
 IE & Co., 478.
 IF & Co., 480, 483.
 IFPC & Co., 490.
 IG, 474, 475, 476.
 IG & Co., 478.
 IGFI, 484.
 IGGH, 478.
 I GREEN & Co., 445.
 IH, 33, 214, 441, 474, 480, 485,
 487, 492.
 IH Co., 472.
 IH & Co., 214, 441, 472.
 I & IW & Co., 379, 435, 451, 484.
 IK, 172, 452, 480, 481, 482.
 IKIW & Co., 483.
 IK & S., 490.
 I KAY & Co., 479.
 IL, 441, 472, 477, 484.
 IL & Co., 465, 476, 477.
 I LINWOOD, 446.
 I LOVE & Co., 437, 445.
 IM, 347, 473, 476, 479.
 IM & Co., 472, 473, 480.

IME, 484.
 IN, 460, 476, 482, 485.
 IN BILBO, 461 *note*.
 INK, 474.
 INM, Co., 490.
 IO, 487.
 IOSA TRAVIS, SHEFFEIED,
 461.
 IP, 478, 480.
 IPC, 487.
 IP & Co., 190, 465, 476, 481.
 IR, 441, 455, 474, 477, 478, 479,
 482.
 IR Co., 433 *note*, 473.
 IR & Co., 481, 483.
 IR & STERLING, 455.
 IS, 450, 473, 476, 477, 478, 479,
 481, 487.
 IS Co., 474.
 IS & Co., 479, 480, 482.
 I & SH, 473.
 I & S ROBERTS, 445.
 ISTS, 485.
 IT, 484.
 I & TS, 470, 483.
 ITY & Co., 477, 480.
 I VICKERS, 497.
 IW, 432, 435, 441, 464, 473, 474,
 477, 478, 479, 484.
 IW & Co., 42, 473, 479.
 IWIR, 484.
 I WOLSTENHOLME, 497.
 IY, 470, 474.
 IY & Co., 470, 474.
 IY Co., 470, 474.
 IOSH, HANCOCK SHEFFIELD,
 32, 441.

J

JB, 436, 440, 485, 489.
 J B DOUBLÉ, 171.
 JBEB, 491.
 JBTB, 492.
 JC & Co., 491.
 JCNC, 488.
 JD & S, 492.
 JF, 489.
 JFF, 489.
 JFF & FF, 492.
 JG, 487.
 JG & Co., 479.
 JH & Co., 486.
 JHS, 492.
 JI, 473.
 JJ, 473.
 J & JB, 487.
 JK & Co., 462, 482, 484.
 JKB TH GW, 493.
 JL, 472.
 JM, 476, 479, 486, 488.
 J & M, 171.
 JM & Co., 480.
 J & M DUBLÉ, 171.
 JN, 485, 488, 490.
 JNPS, 440, 460.
 J NICHOLDS, 447.
 JP, 429.
 JO & Co., 481.
 JR, 481, 487, 488, 490.
 JREER, 492.
 JRGR, 434, 450.
 JRPS, 450.
 JS, 488.

JSR, 441, 455, 475.
 JSR STERLING, 455.
 JS & S, 440.
 J SMITH EXTRA, 460.
 JT, 474, 493.
 JTTT, 491.
 JW, 444, 447, 488.
 JWEH, 465, 487.
 JYC, 489.
 JAMES DIXON & SONS BEST
 BRITANNIA METAL, 497.
 JAMES DIXON & SONS SHEF-
 FIELD, 451.
 JOHN PARSONS & Co., 444.
 JOHN SYKES & Co., 478.
 JOHNSON, 448.
 JONES, 450.
 JORDAN, 448.
 JOSEPHUS SMITH, 438, 451.
 JOS^H LILLY, 449.

K

KELK, 473.
 KW & C, 486.
 K & W, 486.
 K W & Co., 478.
 KIRKBY FOR USE, 438, 448.

L

LAQT FT, 171.
 LB, 477, 489, 491.
 LC, 160, *note*.
 L & Co., 459.
 LL, 484.
 LM, 477.
 L & M, 487.
 LP & Co., 476.
 LAW, 458, 459.
 LAW & SON, 446.
 LAW STERLING, 454.
 LEES, 448.
 L'ESPAGNE, 458.
 LEVRAT, 171.
 LILLY, 449.
 LINWOOD, 447.

M

M, 440.
 MB, 490, 492.
 M & B, 489.
 MB Co., 491.
 M & C, 490.
 M Co, 441.
 MF, 37.
 MF & Co., 37, 472, 482.
 MFRC, 37, 472.
 MH & Co., 475, 480.
 MK, 474.
 MR, 474.
 M & T, 455, 456, 474.
 M & T STERLING, 455, 456.
 MW & Co., 491.
 MADIN, 455.
 MADIN OPUS, 458.
 MANUFACTURED BY E.
 THOMASON & Co., 435, 446.
 MAPPIN BROTHERS, 452.
 MEREDITH, 446.
 MOORE, 444.
 MORTON & Co., 431, 445.
 MORTONS PATENT, 216.
 10M 11M 30M 40M, 170, 171.

N

NC, 486.
NEILL, 488.
NS, 441, 459, 474.
NS & Co., 466, 475.
N SMITH & Co., 431, 444.
NT, 477.

O

O & E, 487.
OPUS, 459.
OVA, 459.

P

P, 449.
PB, 478.
PD, 483.
PE, 171.
PH, 171.
PH DOUBLÉ, 171.
PJ, 473.
PL, 486.
P & M, 492.
PMRT, 475.
PP & Co., 488.
PS, 451, 477, 481.
PS & Co., 489.
PT, 491.
PAPA, 459.
PARKIN, 459, 497.
PATENT, 452.
PATENT WILLMORESS &
WILKESS, 435, 447.
PEAKE, 446.
PEARSON, 448.
PEMBERTON, 449.
PLAQUÉ, 170, 172.
PLAQUÉ BH, 161, 171.
PLAQUÉ FI, 171.
PLAQUÉ FL, 171.
PLAQUÉ FV, 171.
PLATED, 335, 441.
PLUTUS, 459.
PRIME, 451.

Q

Q, 452.

R

RB, 477, 478, 489.
R & B, 452, 490, 491.
RC & Co., 216, 476.
RC & Co., PATENT, 216, 368 *note*.
RCDSRS, 190.
RF, 474.
RG, 479, 482.
RGRG, 452.
RH, 492.
R & H, 488.
RJ, 480.
RK, 473.
RK & Co., 473.
RL, 478.
RLR LOY, 478.
R LAW, 446.
R LOY, 478.
RM, 42, 452, 462, 472, 475.
RM & Co., 41, 472, 475.
RMEH, 401.
RNEMS AP, 172.

RO, 477.
RS, 455.
R & S, 450, 488.
RS & Co., 475, 478.
RS STERLING, 455.
RT, 455, 472, 477.
RT & Co., 477.
RT STERLING, 455.
RW, 482.
RW & W, 452.
Rd JEWESSON MIDLETON &
Co., 452.
REGISTERED BY MAPPLE-
BECK & LOWE, JANU 27,
1840, No. 227, 452.
RODGERS, 450.
RODGERS & SONS, 246.
ROGERS, 449.
ROSENSTRAUCH, 172.
RYLAND, 446.

S

S, 451.
SB, 481, 491.
SB & Co., 491.
SC, 445, 501.
S & C, 489.
SCY & Co., 470, 482.
SC YOUNGE & Co., 448.
S & D, 488.
SD & Co., 475.
SDK & Co., 475.
S EVANS, 449.
SF, 478.
SG & Co., 473.
SH, 485, 486.
S & H, 486, 489, 490.
SH & Co., 447.
SILK, 447.
SJ, 171.
S J DOUBLÉ, 171.
SK, 476, 484.
SKC & Co., 479.
SK & Co., 438, 479.
SM, 482.
S & N, 477.
SO, 456.
SO STERLING, 456.
SP & Co., 475.
SR, 472.
SRCB, 492.
SR & Co., 42, 472, 475, 485.
SRGC & Co., 464, 476.
SS, 450, 460, 485.
S & S, 485.
SS & Co., 459.
S SMITH S, 450, 460, 485.
ST, 484.
STN & H, 482.
S TURLEY, 449.
SW, 473, 490.
SW & Co., 473, 487.
S WORTON, 450.
SALT, 452.
SANSOM, 450.
SCOT, 446.
SET, 459.
SHEMEL, 459.
SHEPHARD, 449.
SILKIRK, 446.
SILVER BORDERS, 82.

SILVER EDGES, 177.
SILVER SOLDER, 335.
SMALL, 448.
SMITH, 448, 450.
SMITH & Co., 431, 444, 447.
SMITH KIRKBY & Co., 497.
SOUND, 459.
STANIFORTH PARKIN & Co.,
444.
STERLING, 453, 454, 455.
STOT, 448.
SUPER, 459.
SURIOUS, 459.
SYKES, 458, 459.
SYKES & Co., 444, 455, 475.
SYKES & Co., STERLING, 455.

T

TA, 474.
TB, 480.
T & B, 488.
TB & Co., 462, 481, 488.
T BEST, 483.
TB & S, 486, 490.
TBSB, 444, 446.
TB & SS, 465.
TC, 440, 475, 481, 483.
TC & S, 485.
TD, 471.
TE, 487, 492.
TF, 488.
TF & Co., 476.
TG, 477.
TG & M, 486.
TH, 473, 486.
THWN, 473.
T & IS, 470, 483.
T J C, 448, 482.
T J C & N, 488.
TJ & NC, 483, 488.
TK, 482.
TL, 397, 425, 441, 454, 472, 473.
TL & Co., 397.
TLDL, 36, 480.
TL LAW TL, 425, 441.
TL STERLING TL, 454.
TL THO LAW TL, 425, 441.
T LAW TL, 472.
TM, 489.
TN, 460, 476, 477, 481.
TN & Co., 482.
T OLDHAM MAKER NOTTING-
HAM, 452.
TP, 474, 478, 481.
TPL, 487.
TRAVIS, SHEFFIELD, 461.
TR, 474, 478, 481, 488.
TS, 475, 482.
TS & Co., 42, 475.
TT, 488, 491.
TV, 483.
TW, 479.
TW & Co., 479.
THOMAS, 448.
THOMAS BOND ST., 429.
THOMASON, 446.
THOS LAW & Co., 444.
TONKS, 446, 450.
TUDOR & Co., 36, 444.
TURTON, 449.
TYNDALL, 448.

U

UW & Co., 485.

V

VR SHEFFIELD, 347.
VEYRAT, 171.

W

WA & Co., 486.
WB, 483, 484, 492.
WB & Co., 455, 472, 483.
WB & Co., STERLING, 455.
WBMS, 450.
WB PINE STRAND, 452.
WB & S, 455, 475.
WB & S STERLING, 455.
W BINGLEY, 445.
WC, 481, 487.
W & Co., 487.
W & Co., S, 451.
W COLDWELL, 446.
WD, 473, 476, 492.
WD & Co., 484.
W F, 473.
W & F, 482.
WFW, 490.
WG, 492.
WG & Co., 476.
W GREEN & Co., 444, 459.WH, 474, 486, 489.
W & H, 491.
WH & Co., 474, 481.
W & HH, 487.
WHIR, 472.
WHIR & Co., 472.
WH & S, 452.
W HIPWOOD, 447.
WJ, 477, 479.
W JERVIS, 445.
W & K, 482.
WK & Co., 487.
WL, 480.
W LINWOOD, 446.
WM, 473, 493.
WM & Co., 472.
W & MD, 492.
W MARKLAND, 449.
WN, 485.
WP, 475, 483, 492.
WR, 347.
W & R, 486.
WR 1830, 246.
WR ASHBERRY PATENT, 497.
WS, 473, 486, 491.
W & S, 487.
WSGS, 490.
WSHS, 489.
WT & Co., 479, 482.
WU, 477.
WW, 483.WW & Co., 476, 486.
WWH, 490, 492.
WWH & Co., 489.
WW & JH, 492.
WW & TB, 485.
WWTJ, 490.
WATCH, 459.
W WATSON MAKER SHEF-
FIELD, 438, 451.
WARZAWA FRAGET, 172.
WATERHOUSE & Co., 435, 447.
WATSON & Co., 37, 445.
WATSON PASS & Co., 448.
WHITE, 448.
WILLMORES & WILKES
PATENT, 435, 447.
WILSON, 452.
WM NEWBOULD & SONS, 446.
WOODWARD, 449.
WRIGHT & FAIRBAIRN, 438,
447.

Y

Y & D, 483.
YG & H, 470, 474.
YWC, 480.

Z

ZC, 459.

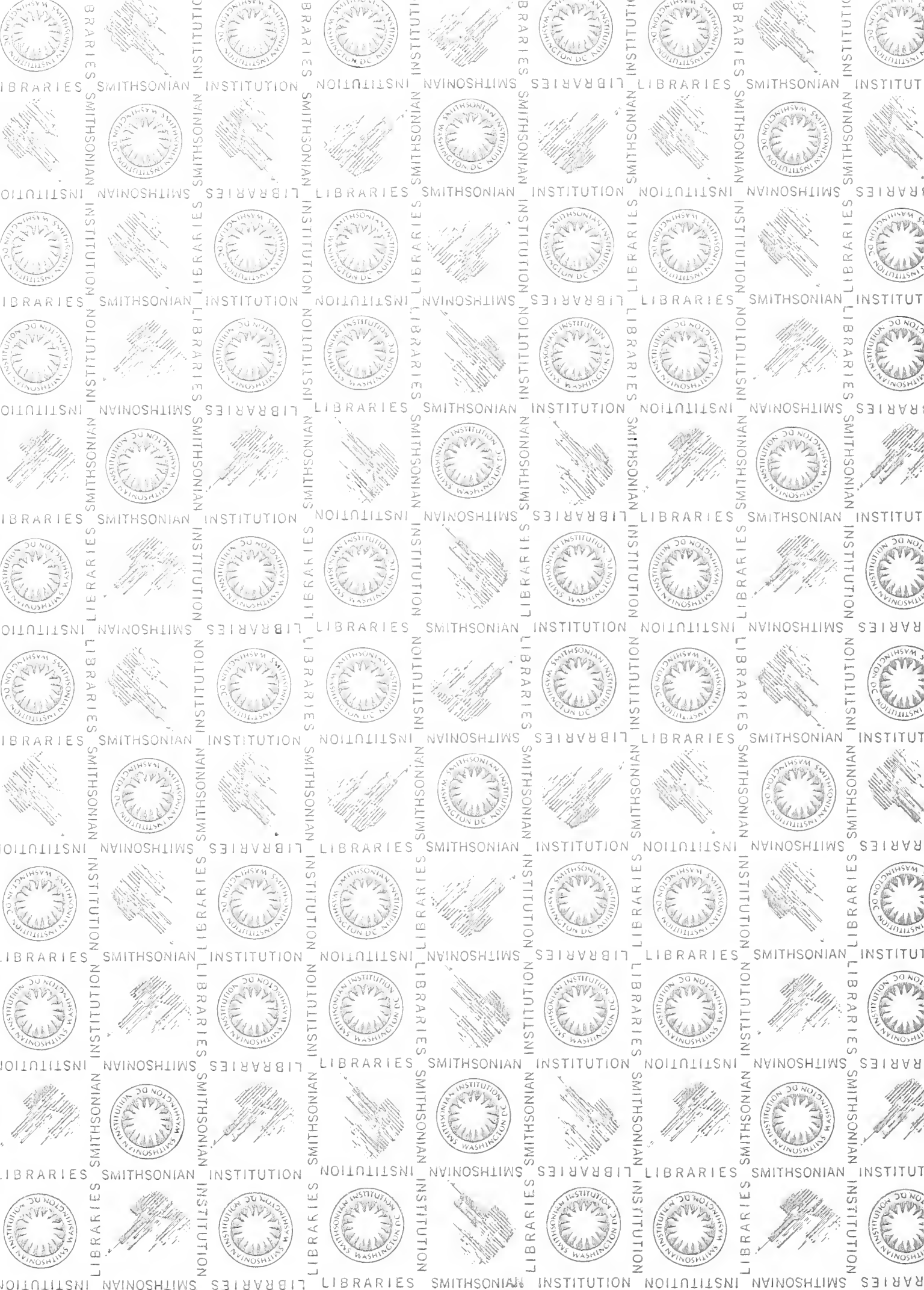

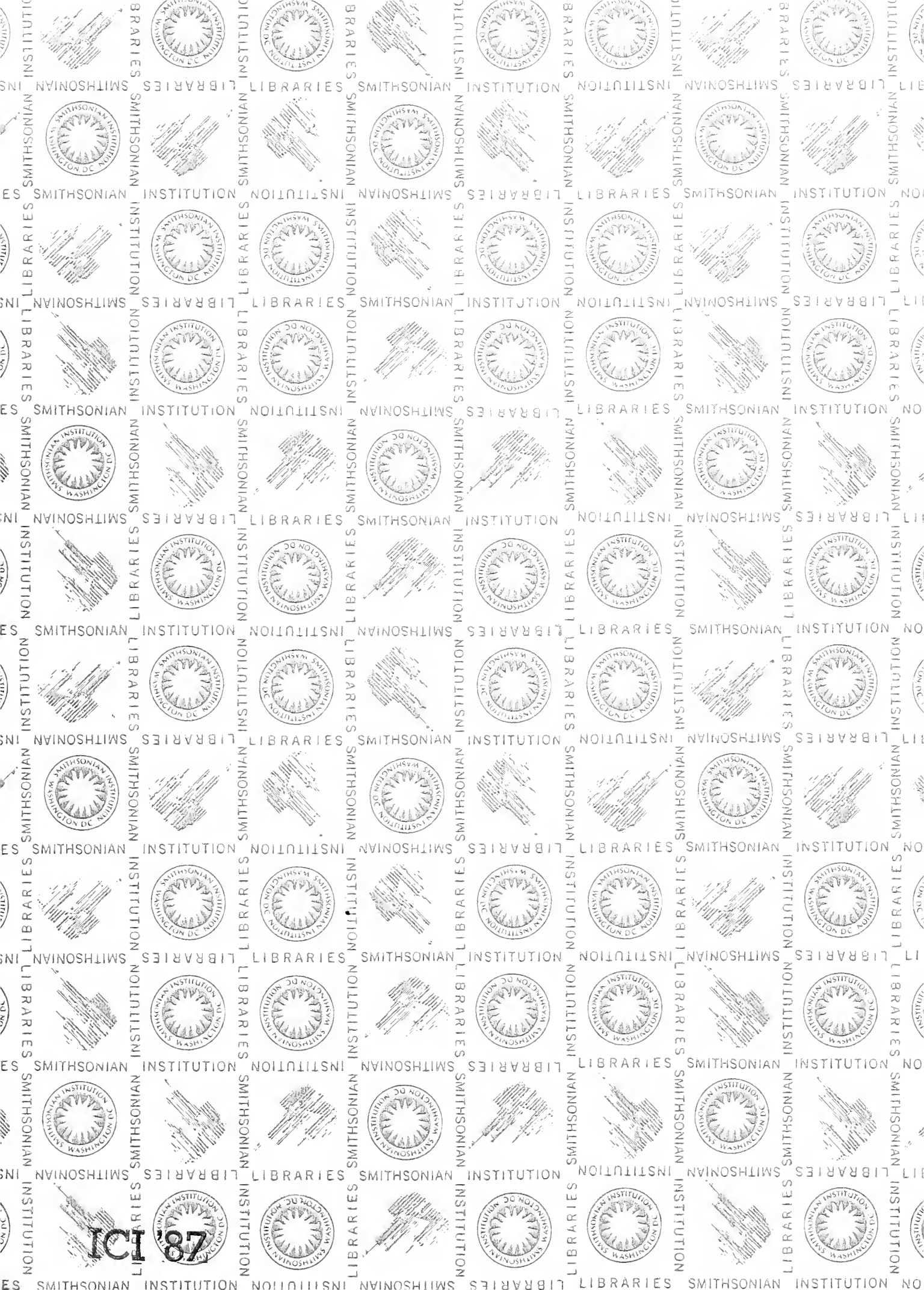

ICI '87

SMITHSONIAN INSTITUTION LIBRARIES



3 9088 00281201 4

chm gNK7250.B7
History of old Sheffield plate